

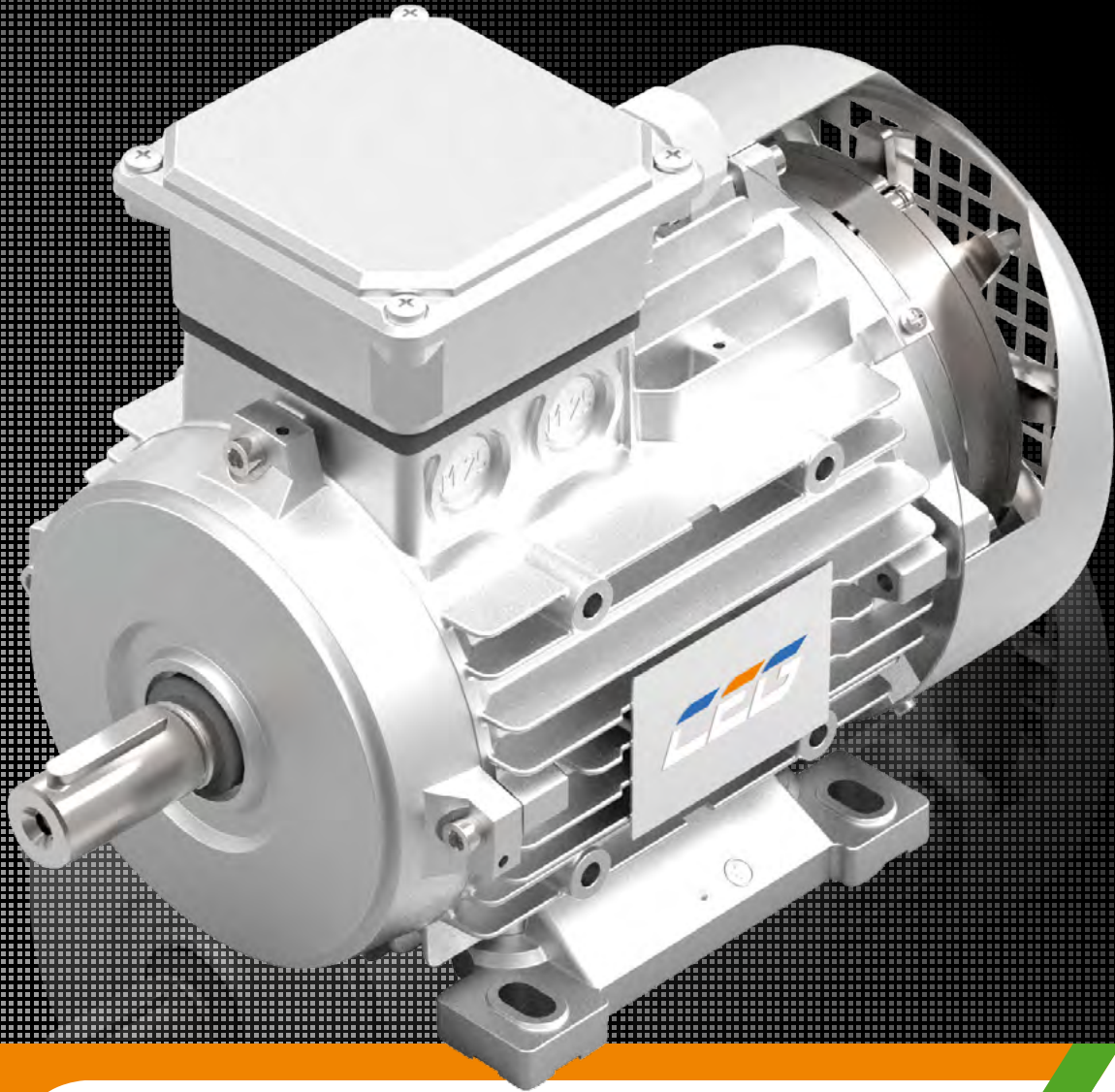

— FROM PROJECT TO PASSION —



Gradual Brake Motors

Three Phase - Single Phase **Technical Datasheets**

EN



ORANGE1 HOLDING

A dynamic, strong and ambitious Group:

Orange1 Holding is an international renown Group, one of the most important European manufacturers of single-phase and three-phase asynchronous electric motors. It has an annual capacity of more than 1 million motors and 5 million electric stators with an annual turnover of approx 200 million euro and more than 1200 workers in 11 production facilities. The group, established in 1971 by Leone Donazzan, chaired today by his son Armando Donazzan, is strongly focused on technological innovation, performance and customization to meet individual clients requirements. As a group of 13 companies it has a powerful advantage: the strength in numbers.



CEG Srl, member of Orange1 Group since 2008, was founded in 1971 as a family-run electromechanical company. CEG Srl has built, over the years, a proper and specific industrial dimension thanks to continuous investments in technology and logistics. The company has a young, motivated and highly skilled workforce. The deep technical knowledge gained over many years of experience combined with the use of technologically advanced tools make the company a reliable partner. Flexibility and efficiency have enabled the company to meet all customers requests by providing personalized solutions for specific applications. This steady commitment for product customization has led to a remarkable technological and process development.

Company's products are targeted to the following applications: wood working machinery wind turbine generators, pumps, foodstuffs machinery, textile machinery, machinery for the chemical industry, wine sector and automation. Ceg Srl is well known for its brake motors and low centre motors.

Gradual Brake Motors

As shown in the Tables given there is an opportunity for manufacturing - upon request subject to additional cost - version compliant with the following regulations:

UL – CSA approved: the motor is manufactured with approved materials and equipped with a plate bearing the exclusive certification marks of this regulation. The ID files attributed to CEG approved. Products are E176350 for UL certification and LR109925-1 for CSA certification.



CABLE GLAND	M56 ÷ M71	1 M16 x 1,5
	M80 ÷ M90s	1 M20 x 1,5
	M90L ÷ M132M	1 M25 x 1,5
	M160M ÷ M180L	2 M32 x 1,5

MANUFACTURING STANDARD

rated voltage	MT 230/400V 50Hz (Pn ≤ 3 kW) - 400/690V 50Hz (Pn ≥ 4 kW) DP 400V 50Hz / MM 230V 50Hz
rated voltage brake	230V (Pn ≤ 3 kW) 400V (Pn ≥ 4 kW)
Rectifier (FPC)	Half wave or full wave
Protection degree	IP54
Bearings	2RS
Insulation class	F
Duty	S1
Mounting arrangement	IM B3 top terminal
Frame	Aluminium pressure die casting, removable feet
Terminal box	Two aluminium components
Fan cover	Galvanized steel sheet
Painting	Not painted
Balancing	Full key

Gradual Brake Motors



This type of brake is best suited for all those applications where a gradual stop of the moving parts is required but without any specific requirements for precision. Due to the small friction force received the FPC brake torque is reduced so as to allow for progressive, silent stopping thus preventing any possible damage to people and machines. The braking action is generated through the pressure exerted by some springs which keep the friction gasket of the mobile anchoring device in close contact with the internal surface of the cast-iron vent. To release the brake energize the electromagnet coil through the power unit.

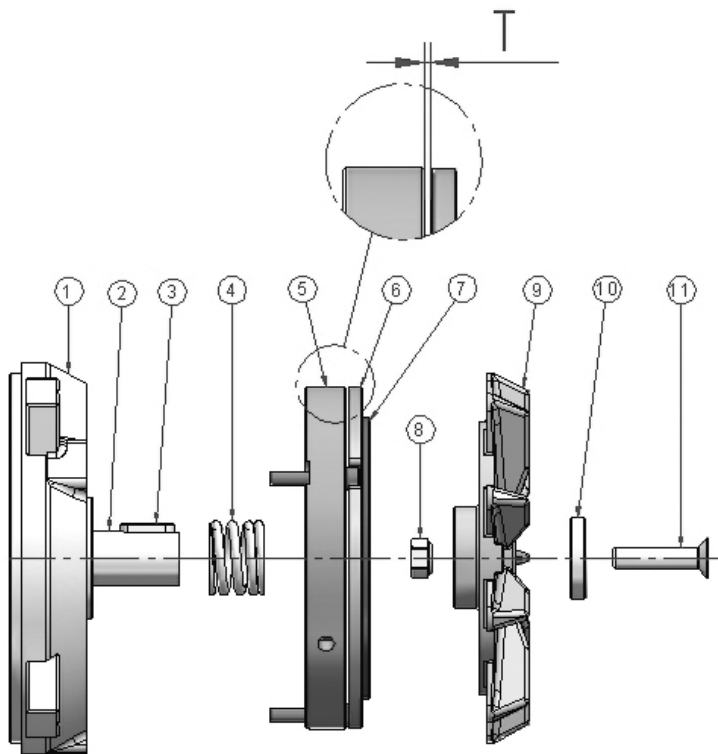

1	FPC end-shield
2	Shaft
3	Key
4	Spring
5	Brake coil
6	Mobile anchor
7	Friction pad
8	Nuyloc nut
9	Cooling fan (cast iron)
10	Washer
11	Adjustment screw

Size	Braking torque	Power	Closing Time	Release time	Braking gap
	Nm	W	ms	ms	mm
M63	2,5	15	20	40	0,2
M71	4	15	15	100	0,2
M80	9	20	15	120	0,2
M90	9	20	15	120	0,2
M100	12	30	10	200	0,25
M112	12	30	10	200	0,25
M132	30	65	10	200	0,3
M160	30	65	13	215	0,3

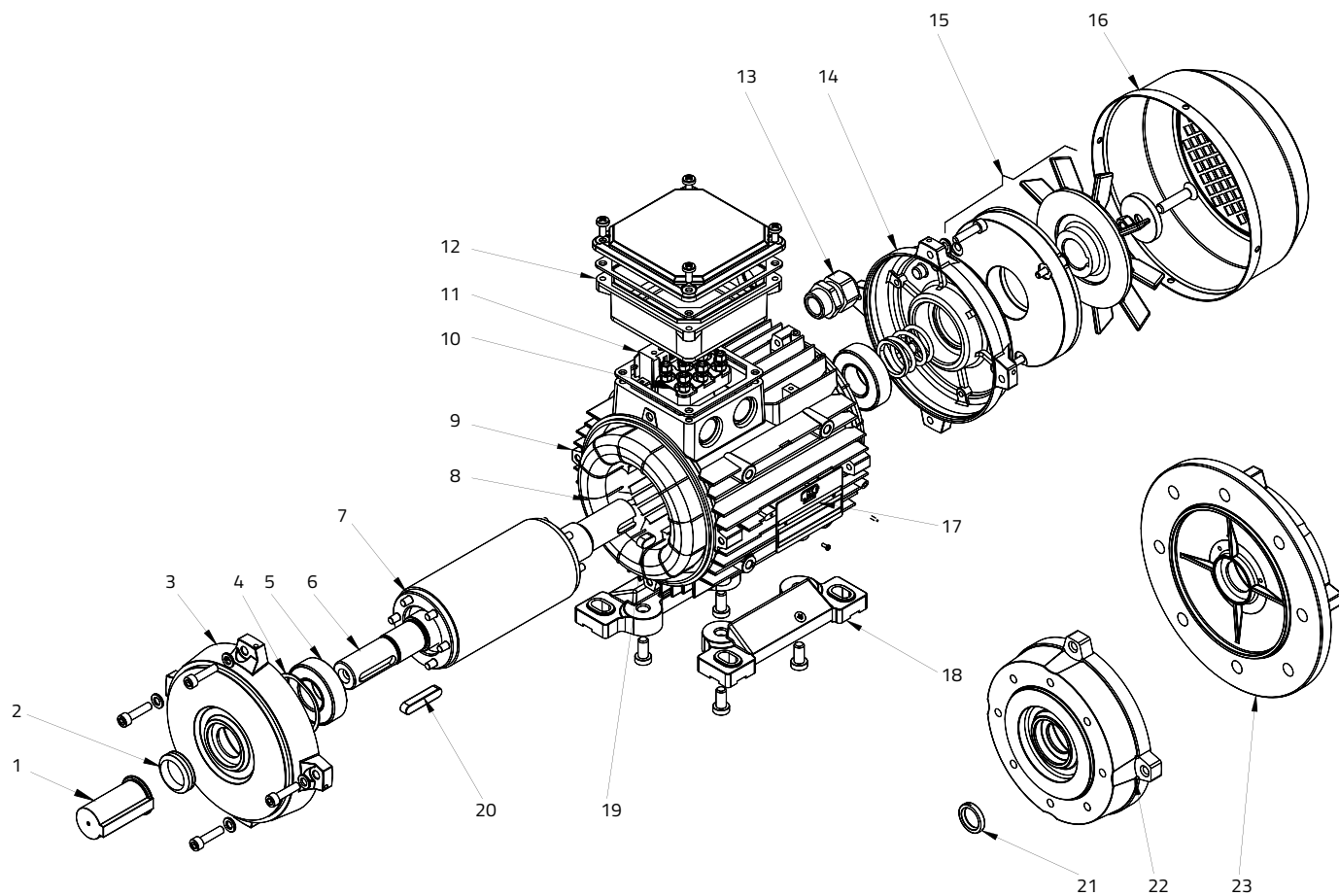

1	Shaft protection	13	Cable gland
2	Dust seal (V-ring)	14	End-shield (non-drive end)
3	End-shield (drive end)	15	FPC Brake group
4	Pre-load washer	16	FH Fan cover
5	Bearing	17	Nameplate
6	Shaft	18	Foot
7	Rotor	19	Driving hub key
8	Stator assembly	20	Shaft key
9	Casing	21	Oil seal
10	Terminal board	22	B14 flange
11	Rectifier	23	B5 flange
12	Terminal box		

Legend

size	Pn	n	In	Cosφ	η	Mn	Mm
frame size	rated power	rated speed	rated current	power factor	efficiency	rated torque	maximum torque
Ms	Is	Cm	J	kg	UL / CSA / ATEX		
stand-still torque	locked-rotor current	run capacitor	inertia	weight	versions with extra price		

MTFPC

THREE PHASE motors one speed with gradual brake

SIZE	Pn		n	In(400V)	Cosφ	η	Mn	Mm/Mn	Ms/Mn	Is/In	J	kg	UL	CSA
	kW	Hp	min ⁻¹	A		%	Nm				kgm ²			
3000 min⁻¹ 2 poles 50 Hz														
M63a	0,18	0,25	2810	0,6	0,71	64	0,63	2,9	2,6	3,9	0,00049	5,1	x	x
M63b	0,25	0,35	2840	0,8	0,68	68	0,84	3,3	3,4	4,5	0,00051	5,4	x	x
M71a	0,37	0,5	2800	1,1	0,75	68	1,26	2,9	2,8	4,1	0,00064	7,1	x	x
M71b	0,55	0,75	2800	1,4	0,8	72	1,9	2,7	2,5	4,5	0,00074	7,8	x	x
M80a	0,75	1	2790	1,9	0,79	72	2,5	3,3	3,4	5,3	0,00149	10,6	x	x
M80b	1,1	1,5	2815	2,8	0,77	73	3,7	3,2	2,9	4,8	0,00161	11,7	x	x
M80c	1,5	2	2800	3,9	0,75	75	5,12	3,4	3	4,6	0,00178	12,7	x	x
M90Sa	1,5	2	2850	3,7	0,78	76	5	3,4	3	3	0,00216	14,5	x	x
M90Sb	1,85	2,5	2830	4,5	0,79	75	6,24	2,9	2,9	5,1	0,00216	15	x	x
M90La	2,2	3	2830	4,85	0,86	77	7,42	2,6	2,6	5,4	0,00238	17,3	x	x
M90Lb	3	4	2860	6,4	0,85	80	10	3,1	3	6,2	0,00265	19,5	x	x
M100La	3	4	2855	6,6	0,83	80	10	3,4	3,2	6,2	0,00476	23	x	x
M100Lb	4	5,5	2875	8,5	0,81	84	13,3	3,7	3,1	7,6	0,00577	27,5	x	x
M112Ma	4	5,5	2890	9,2	0,79	80	13,2	3,4	3	6,2	0,00609	29,2	x	x
M112Mb	5,5	7,5	2900	12	0,81	82	18,1	3,2	3	6,5	0,00726	35,5	x	x
M112Mc	7,5	10	2890	16,5	0,8	82	24,8	3,5	2,8	7	0,00484	34,5	x	x
M132Sa	5,5	7,5	2900	12,3	0,82	79	18,1	3	3	6,9	0,014	44,3	x	x
M132Sb	7,5	10	2920	15,4	0,83	85	24,5	3,9	3,3	7,4	0,0156	50	x	x
M132Ma	11	15	2920	21,8	0,83	87	36	3,7	3,3	7	0,0172	58	x	x
M160Ma	11	15	2940	21,7	0,86	84	35,7	3,1	3,3	6,7	0,0384	79	x	x
M160Mb	15	20	2955	28,9	0,86	86	48,5	3,94	3,5	7,5	0,0458	93	x	x
1500 min⁻¹ 4 poles 50 Hz														
M63a	0,135	0,18	1360	0,52	0,65	58	0,98	2,2	2,3	2,5	0,000524	5	x	x
M63b	0,185	0,25	1350	0,7	0,68	55	1,31	2,4	2,4	2,8	0,000564	5,7	x	x
M71a	0,25	0,35	1400	0,85	0,68	63	1,71	2,7	2,6	3,6	0,00186	7,5	x	x
M71b	0,37	0,5	1380	1,15	0,72	64	2,56	2,6	2,5	4,1	0,00112	8	x	x
M80a	0,55	0,75	1390	1,5	0,8	66	3,78	1,9	1,8	3,7	0,00234	10,5	x	x
M80b	0,75	1	1405	2,1	0,73	72	5,1	2,4	2,3	5	0,00277	12	x	x
M90S	1,1	1,5	1370	2,8	0,82	70	7,67	2,1	2,1	4,3	0,00291	14,5	x	x
M90La	1,5	2	1410	3,9	0,74	75	10,16	2,9	2,8	4,5	0,0034	16,9	x	x
M90Lb	1,85	2,5	1400	4,4	0,78	78	12,6	2,9	2,7	5	0,0038	18,5	x	x
M100La	2,2	3	1410	5,4	0,77	77	14,9	2,5	2,1	4,7	0,00935	21,5	x	x
M100Lb	3	4	1410	7,1	0,79	79	20,3	2,7	2,6	5,3	0,00728	24,9	x	x
M100Lc	4	5,5	1400	9	0,84	77	27,3	2,4	2,1	4,6	0,00773	26,8	x	x
M112Ma	4	5,5	1420	8,8	0,81	81	26,9	2,9	2,4	5,2	0,0125	31,7	x	x
M112Mb	5,5	7,5	1390	11,6	0,83	82	37,8	2,5	2,4	5,2	0,0142	33,2	x	x
M132S	5,5	7,5	1425	11,5	0,85	81	36,8	2,5	2,6	5,1	0,0245	49,5	x	x
M132Ma	7,5	10	1450	17,5	0,74	84	49,4	3,1	2,5	5,3	0,0287	60	x	x
M132Mb	9,2	12,5	1445	18,7	0,82	87	60,8	2,9	2,3	5,9	0,0309	63,9	x	x
M132Mc	11	15	1425	22,3	0,85	84	73,7	2,1	2,3	4,6	0,03325	68	x	x
M160M	11	15	1460	21,7	0,82	89	72	2,6	2,3	5,5	0,06038	86,2	x	x
M160L	15	20	1460	30,2	0,8	90	98,1	2,3	2,8	5,5	0,07431	104,5	x	x

THREE PHASE motors one speed with gradual brake

SIZE	Pn		n	In(400V)	Cosφ	η	Mn	Mm/Mn	Ms/Mn	Is/In	J	kg	UL	CSA
	kW	Hp	min ⁻¹	A		%	Nm				kgm ²			
1000 min-1 6 poles 50 Hz														
M63b	0,12	0,17	860	1	0,57	30	1,33	2,4	2,4	1,7	0,00059	6,2	x	x
M71a	0,185	0,25	900	0,85	0,62	52	1,96	2,1	2,1	2,6	0,00112	7,7	x	x
M71b	0,25	0,35	910	1,05	0,62	55	2,62	2,2	2,2	2,5	0,00134	9,2	x	x
M80a	0,37	0,5	865	1,25	0,79	55	4,08	1,7	1,5	2,8	0,0025	10,5	x	x
M80b	0,55	0,75	870	1,7	0,8	60	6,04	1,9	1,7	3	0,00296	12,2	x	x
M90S	0,75	1	915	2,2	0,71	71	7,83	2,2	2	3,3	0,00389	14	x	x
M90L	1,1	1,5	900	3,3	0,73	67	11,67	2,2	2,1	3,3	0,00373	16,7	x	x
M100L	1,5	2	950	4,1	0,7	75	15,1	2,7	2,1	4,7	0,00827	22,5	x	x
M112M	2,2	3	955	5,3	0,77	78	22	2,6	1,5	5,1	0,01625	33,7	x	x
M132S	3	4	955	7,4	0,78	75	30	2,5	1,6	4,7	0,0284	44,5	x	x
M132Ma	4	5,5	950	9	0,79	81	40,2	2,5	1,7	5,1	0,03194	54,2	x	x
M132Mb	5,5	7,5	950	11,9	0,8	84	55,3	2,3	1,3	2,7	0,03721	60	x	x
M160M	7,5	10	960	16	0,8	86	74,6	2,5	2,3	5	0,0839	85	x	x
M160L	11	15	970	23,9	0,75	89	108,3	3,6	2,8	6,4	0,14137	117	x	x
750 min-1 8 poles 50 Hz														
M80a	0,185	0,25	690	0,95	0,57	49	2,56	2,2	1,9	2,3	0,0025	10,9	x	x
M80b	0,25	0,35	670	1,2	0,62	50	3,56	1,8	1,7	2,3	0,00296	12,2	x	x
M90S	0,37	0,5	660	1,5	0,63	57	5,35	1,6	1,4	2,1	0,00309	14,8	x	x
M90L	0,55	0,75	610	2,15	0,7	53	8,61	1,2	1	1,5	0,0034	16,5	x	x
M100La	0,75	1	690	2,5	0,68	63	10,38	1,9	1,4	3	0,00828	21,5	x	x
M100Lb	1,1	1,5	680	3,5	0,7	65	15,44	1,8	1,5	3	0,00981	25,8	x	x
M112M	1,5	2	700	5	0,65	67	20,5	2	1,6	3	0,01451	31	x	x
M132S	2,2	3	720	6	0,66	81	29,2	2,5	1,5	4,1	0,03194	49,3	x	x
M132M	3	4	715	8	0,69	78	40,3	2,2	1,6	4	0,03721	56,5	x	x
M160Ma	4	5,5	730	11	0,65	81	52,3	2,2	2,1	4	0,0839	91	x	x
M160Mb	5,5	7,5	720	15,3	0,65	80	73	2,9	2,4	4,5	0,10816	97	x	x
M160L	7,5	10	710	17	0,76	84	100,9	2,1	1,5	4	0,11715	117	x	x

THREE PHASE motors two speed with gradual brake

SIZE	Pn		n min ⁻¹	In(400V) A	Cosφ	η %	Mn Nm	J kgm ²	kg	UL	CSA
	kW	Hp									
3000/1500 min⁻¹ 2/4 poles 50 Hz											
M63	0,22/0,15	0,3/0,2	2760-1400	0,67-0,57	0,88-0,63	54-60	0,76-1	0,00059	5,7	x	x
M71a	0,3/0,22	0,4/0,3	2900-1445	1,2-1	0,62-0,57	58-56	0,99-1,45	0,00112	7,8	x	x
M71b	0,55/0,37	0,75/0,5	2830-1405	1,3-1,25	0,82-0,62	75-69	1,85-2,5	0,00065	8,8	x	x
M80a	0,6/0,45	0,8/0,6	2840-1415	1,7-1,3	0,77-0,74	65-65	1,74-1,35	0,00191	12	x	x
M80b	0,8/0,6	1,1/0,8	2875-1420	2,1-2,06	0,77-0,64	70-66	2,66-4	0,00212	12,2	x	x
M80c	1,1/0,75	1,5/1	2865-1420	2,77-2,46	0,82-0,66	70-67	3,66-5,04	0,00231	13,7	x	x
M90Sa	1,5/1,1	2/1,5	2850-1425	4,1-2,9	0,74-0,73	71-76	5-7,4	0,00309	15,2	x	x
M90Sb	1,85/1,25	2,5/1,7	2840-1420	5-3,1	0,77-0,76	70-76	6,22-8,4	0,0034	16,7	x	x
M90La	2,2/1,5	3/2	2840-1410	5-3,5	0,84-0,79	75-78	7,4-10,15	0,00375	19	x	x
M100La	3/2,2	4/3	2850-1410	7,25-5,35	0,84-0,81	70-75	10-13,5	0,00632	23,1	x	x
M100Lb	4/3	5,5/4	2875-1425	9,8-7,2	0,8-0,79	73-73	13,3-20,1	0,00719	26,5	x	x
M112M	4,5/3,3	6/4,5	2865-1430	10,6-7,65	0,88-0,8	70-78	15,1-22,2	0,01158	35,2	x	x
M132Sa	5,5/4,5	7,5/6	2915-1450	12,9-9,9	0,82-0,81	77-81	18-29,6	0,02456	46,5	x	x
M132Sb	7,5/6	10/8	2910-1445	18,1-12,9	0,78-0,82	77-82	24,6-39,6	0,02727	50	x	x
M132M	8,1/6,6	11/9	2915-1440	17,6-14,4	0,88-0,85	76-78	26,5-47,8	0,02871	57,4	x	x
M160M	11/9	15/12	2970-1480	25,9-19,5	0,75-0,77	82-87	35,4-58,1	0,06513	107	x	x
M160L	14/11	19/15	2950-1470	32-23	0,76-0,77	83-88	45,3-71,5	0,07431	114	x	x
1500/750 min⁻¹ 4/8 poles 50 Hz											
M71	0,185/0,09	0,25/0,12	1440-700	0,74-0,97	0,66-0,57	55-25	1,23-1,23	0,00134	11	x	x
M80a	0,37/0,2	0,5/0,28	1400-700	0,96-1,1	0,81-0,6	65-45	2,52-2,73	0,00296	12,2	x	x
M80b	0,55/0,3	0,75/0,4	1380-685	1,35-1,65	0,84-0,6	70-45	3,8-4,2	0,00318	12,4	x	x
M90S	0,75/0,37	1/0,5	1360-680	1,7-1,7	0,88-0,58	70-53	5,26-5,2	0,00309	15,2	x	x
M90L	1/0,5	1,35/0,7	1375-690	2,2-2,3	0,88-0,56	74-56	6,94-6,92	0,0034	16,5	x	x
M100La	1,4/0,66	1,9/0,9	1400-680	3,2-2,5	0,85-0,6	75-63	9,55-9,27	0,00632	22	x	x
M100Lb	1,6/0,9	2,2/1,2	1390-700	3,5-3,3	0,88-0,6	75-65	11-12,3	0,00728	24,5	x	x
M112Ma	1,85/1,1	2,5/1,5	1420-725	4,1-4	0,88-0,6	76-67	12,9-13,2	0,011765	31	x	x
M112Mb	2,2/1,4	3/1,9	1440-720	4,6-4,4	0,89-0,66	78-69	14,6-18,6	0,01625	33,7	x	x
M132S	3,7/2	5/2,8	1450-720	7,4-7,1	0,9-0,59	83-73	24,4-26,5	0,03194	49,5	x	x
M132M	5,1/3	7/4	1435-710	10,2-8,3	0,92-0,71	79-74	33,9-40,4	0,03721	56,3	x	x
M160Ma	6/4	8/5,5	1440-725	13-11,8	0,86-0,63	78-78	39,8-52,7	0,0839	84,9	x	x
M160Mb	7,5/5	10/6,8	1430-715	15,7-13,9	0,89-0,67	78-78	50-66,8	0,0839	84,9	x	x
1500/1000 min⁻¹ 4/6 poles 50 Hz											
M71	0,3/0,22	0,4/0,3	1430-830	1,2-0,9	0,7-0,74	60-50	2-2,5	0,00137	7,9	x	x
M80	0,55/0,37	0,75/0,5	1445-940	1,5-1,2	0,77-0,76	67-50	3,6-3,8	0,00338	13,7	x	x
M90S	0,75/0,55	1/0,75	1445-945	2,1-1,8	0,77-0,75	66-60	5-5,5	0,00309	15,2	x	x
M90L	1,1/0,75	1,5/1	1420-925	2,77-2,37	0,8-0,74	72-62	7,4-7,74	0,0045	16,9	x	x
M100L	1,5/0,9	2/1,2	1465-965	4,4-2,7	0,7-0,7	70-70	9,8-8,9	0,00981	25,5	x	x
M112Ma	1,85/1,32	2,5/1,8	1465-965	4,6-3,6	0,8-0,75	72-70	12-12,9	0,01451	31,7	x	x
M112Mb	2,2/1,5	3/2	1460-970	5,1-4,1	0,85-0,75	73-70	14,4-14,9	0,01625	34,2	x	x
M132S	3,3/2,2	4,5/3	1460-970	7,3-5,7	0,83-0,71	79-78	21,6-21,7	0,03176	40,5	x	x
M132Ma	4/2,5	5,5/3,5	1460-965	8,6-7	0,82-0,72	82-75	26,2-25,7	0,03194	50,5	x	x
M132Mb	5,5/4	7,5/5,5	1460-975	11,2-10	0,87-0,75	82-77	36-39,2	0,03721	57,5	x	x
M160M	7,5/5	10-6,8	1470-960	15/11	0,84-0,82	86-80	48,7-49,7	0,10816	97	x	x
1000/750 min⁻¹ 6/8 poles 50 Hz V=400V											
M80	0,25/0,14	0,35/0,19	920-685	0,96-0,73	0,78-0,71	47-38	2,6-1,95	0,00134	14,2	x	x
M90L	0,55/0,25	0,75/0,35	920-700	1,6-1,1	0,77-0,68	65-48	5,7-3,4	0,00425	17,2	x	x
M100L	0,95/0,55	1,3/0,75	960-700	2,9-1,9	0,72-0,7	65-60	9,5-7,5	0,00828	26,5	x	x
M112M	1,5/0,75	2/1	965-730	4,1-2,5	0,72-0,68	73-63	15-9,8	0,01622	33,7	x	x
M132S	2,2/1,1	3/1,5	960-740	6,1-3,6	0,72-0,78	73-65	22-14,2	0,03275	63,5	x	x
M132M	3/1,85	4/2,5	975-715	8,3-4,9	0,68-0,72	77-76	29,4-24,7	0,03543	67,5	x	x

SINGLE PHASE motors with gradual brake

SIZE	Pn		n	In(230V)	Cosφ	η	Mn	Mm/Mn	Is/In	Cm	J	kg	UL	CSA
	kW	Hp	min ⁻¹	A		%	Nm			μF	kgm ²			
3000 min⁻¹ 2 poles 50 Hz														
M63a	0,185	0,25	2730	1,4	0,99	58	0,65	1	2,8	8	0,0005	5,4	x	x
M63b	0,25	0,35	2750	2,1	0,95	55	0,87	1,1	2,7	12	0,00053	5,9	x	x
M71a	0,37	0,5	2700	3,2	0,84	61	1,31	0,67	2,7	12	0,00087	7,9	x	x
M71b	0,55	0,75	2730	4,3	0,92	61	1,92	0,62	2,8	16	0,00085	9	x	x
M80a	0,75	1	2770	5,1	0,94	68	2,58	0,83	3,6	20	0,00176	12,2	x	x
M80b	1,1	1,5	2750	7,1	0,96	70	3,82	0,55	3,5	25	0,00193	13,6	x	x
M80c	1,5	2	2700	9,8	0,98	70	5,3	0,58	3,6	35	0,00202	14,2	x	x
M90Sb	1,5	2	2750	9	0,98	75	5,2	0,74	3,7	40	0,00237	16,9	x	x
M90La	1,85	2,5	2780	10,7	0,99	76	6,35	0,65	3,5	50	0,00305	19	x	x
M90Lb	2,2	3	2740	12,7	0,99	76	6,67	0,7	3	60	0,00305	19	x	x
M100L	2,5	3,5	2850	14,7	0,99	73	8,4	0,7	4	80	0,0065	25,5	x	x
1500 min⁻¹ 4 poles 50 Hz														
M63a	0,11	0,15	1330	1,15	0,93	45	0,79	1	1,6	6,3	0,00026	5	x	x
M63b	0,185	0,25	1350	1,7	0,99	48	1,31	1	1,6	10	0,00066	5,7	x	x
M71a	0,25	0,35	1330	2	0,93	60	1,8	1	2,3	10	0,00111	7,8	x	x
M71b	0,37	0,5	1300	3,2	0,92	55	2,72	1	2,3	16	0,00133	9	x	x
M80a	0,55	0,75	1360	3,7	0,98	64	3,86	0,52	2,7	14	0,00252	11,1	x	x
M80b	0,75	1	1400	5,3	0,94	65	5,1	0,5	3,5	20	0,00294	12,6	x	x
M90S	1,1	1,5	1380	6,7	0,98	71	7,6	0,52	3,3	35	0,0038	15,5	x	x
M90La	1,5	2	1360	9,3	0,96	73	10,8	0,5	3	45	0,0037	18,4	x	x
M90Lb	1,85	2,5	1360	12,1	0,91	73	13	0,5	3,1	55	0,00391	20	x	x
M100La	1,85	2,5	1360	12,2	0,94	70	13	0,6	3	55	0,00668	23,6	x	x
M100Lb	2,2	3	1350	13	0,97	76	15,6	0,5	4	70	0,00771	26,4	x	x
1000 min⁻¹ 6 poles 50 Hz														
M71	0,185	0,25	920	1,8	0,8	55	1,92	0,7	2,2	8	0,00112	8,3	x	x
M80a	0,25	0,35	940	2,5	0,8	55	2,54	0,6	2,7	10	0,00252	10,7	x	x
M80b	0,37	0,5	920	3,3	0,94	51	3,84	0,65	2,1	16	0,00396	12,2	x	x
M90S	0,55	0,75	915	4,25	0,88	64	5,74	0,5	2,3	20	0,0052	14,5	x	x
M90La	0,75	1	945	5,8	0,88	64	7,6	0,5	2,7	25	0,00419	16,7	x	x
M90Lb	1,1	1,5	930	8,3	0,96	60	11,3	0,54	2,5	35	0,0039	19,2	x	x
M100La	1,1	1,5	935	8,1	0,91	65	11,25	0,4	2,3	45	0,00608	23,5	x	x
M100Lb	1,5	2	930	10,6	0,96	64	15,4	0,5	2,9	50	0,00608	24,8	x	x

Dimensions B3 - B5



B3

- B6
- B7
- B8
- V5
- V6

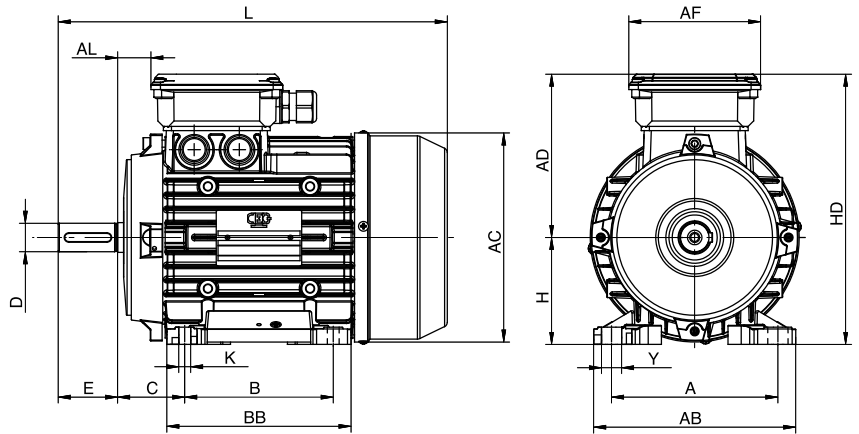

B5

- V1
- V3

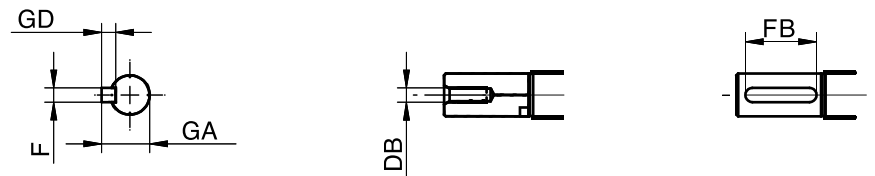
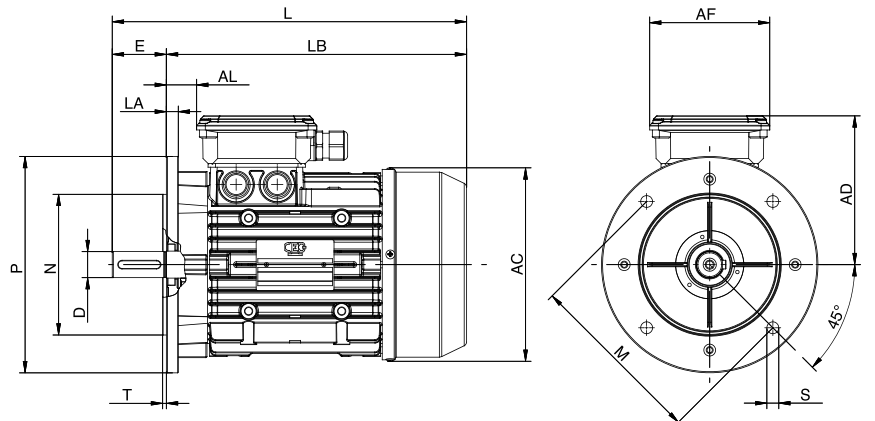

Dimensions in mm

Tolerances (DIN 748-7160-7161-42948)

D	≤ 28 mm	j6
	38 ÷ 50 mm	k6
	> 50 mm	m6
N	≤ 230 mm	j6
	> 230 mm	h6
H	≤ 250 mm	+0 / -0,5 mm
	> 250 mm	+0 / -1 mm

SIZE	B3																B5											
	A	AB	B	BB	C	D	E	H	HD	L	K	Y	AC	AD	AF	AL	F	FB	GA	GD	DB	P	N	M	T	S	LB	LA
M63	100	120	80	106	40	11	23	63	176	249	7	12	123	113	93	19	4	15	12,5	4	M4	140	95	115	2,5	10	226	10
M71	112	136	90	108	45	14	30	71	196	256	8	12	147	125	93	24	5	20	16	5	M5	160	110	130	3	10	226	9
M80	125	160	100	125	50	19	40	80	220	291	9,5	17	165	140	111	23	6	30	21,5	6	M6	200	130	165	3,5	12	251	10,5
M90S	140	170	100	131	56	24	50	90	235	305	9,5	17	181	145	111	28	8	40	27	7	M8	200	130	165	3,5	12	255	10,5
M90L	140	170	125	156	56	24	50	90	235	330	9,5	17	181	145	111	28	8	40	27	7	M8	200	130	165	3,5	12	280	10,5
M100L	160	200	140	170	63	28	60	100	256	370	11	21	198	156	111	36	8	50	31	7	M10	250	180	215	4	14,5	310	14
M112M	190	225	140	177	70	28	60	112	292	388	11	21	222	180	124	38	8	50	31	7	M10	250	180	215	4	14,5	328	14
M132S	216	260	140	181	89	38	80	132	330	460	11	21	264	198	133	44	10	70	41	8	M12	300	230	265	4	14,5	380	20
M132M	216	260	178	220	89	38	80	132	330	500	11	21	264	198	133	44	10	70	41	8	M12	300	230	265	4	14,5	420	20
M160M	254	318	210	260	108	42	110	160	403	770	13	23	317	243	186	52,5	12	90	45	8	M16	350	250	300	5	18,5	660	15
M160L	254	318	254	304	108	42	110	160	403	805	13	23	317	243	186	52,5	12	90	45	8	M16	350	250	300	5	18,5	695	15

All the charts include approximate values and dimensions. CEG Srl reserve the right to modify values and/or dimensions without notice.

Dimensions B14



B14

V18
V19

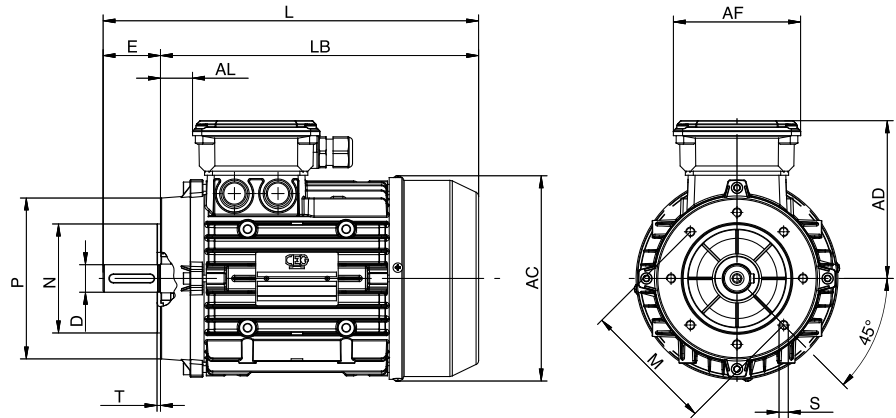

Dimensions in mm

Tolerances (DIN 748-7160-7161-42948)

D	≤ 28 mm	j6
	38 - 50 mm	k6
	> 50 mm	m6
N	≤ 230 mm	j6
	> 230 mm	h6
H	≤ 250 mm	+0 / -0,5 mm
	> 250 mm	+0 / -1 mm

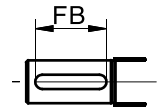
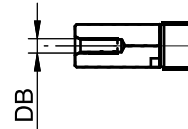
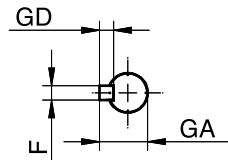

SIZE																					B14							
	A	AB	B	BB	C	D	E	H	HD	L	K	Y	AC	AD	AF	AL	F	FB	GA	GD	DB	P	N	M	T	S	LB	LA
M63	100	120	80	106	40	11	23	63	176	249	7	12	123	113	93	19	4	15	12,5	4	M4	90	60	75	2,5	M5	226	10
M71	112	136	90	108	45	14	30	71	196	256	8	12	147	125	93	24	5	20	16	5	M5	105	70	85	3	M6	218	9
M80	125	160	100	125	50	19	40	80	220	291	9,5	17	165	140	111	23	6	30	21,5	6	M6	120	80	100	3	M6	239	10,5
M90S	140	170	100	131	56	24	50	90	235	305	9,5	17	181	145	111	28	8	40	27	7	M8	140	95	115	3	M8	255	10,5
M90L	140	170	125	156	56	24	50	90	235	330	9,5	17	181	145	111	28	8	40	27	7	M8	140	95	115	3	M8	280	10,5
M100L	160	200	140	170	63	28	60	100	256	370	11	21	198	156	111	36	8	50	31	7	M10	160	110	130	3,5	M8	310	14
M112M	190	225	140	177	70	28	60	112	292	388	11	21	222	180	124	38	8	50	31	7	M10	160	110	130	3,5	M8	325	14
M132S	216	260	140	181	89	38	80	132	330	460	11	21	264	198	133	44	10	70	41	8	M12	200	130	165	4	M10	380	20
M132M	216	260	178	220	89	38	80	132	330	500	11	21	264	198	133	44	10	70	41	8	M12	200	130	165	4	M10	420	20
M160M	254	318	210	260	108	42	110	160	403	770	13	23	317	243	186	52,5	12	90	45	8	M16	250	180	215	5	M12	660	15
M160L	254	318	254	304	108	42	110	160	403	805	13	23	317	243	186	52,5	12	90	45	8	M16	250	180	215	5	M12	695	15

All the charts include approximate values and dimensions. CEG Srl reserve the right to modify values and/or dimensions without notice.



ORANGE1
HOLDING

CEG S.r.l.

Via A. Grandi, 23
47030 San Mauro Pascoli, FC (IT)
T. +39 0541 815611
F. +39 0541 815684

info@orange1.eu
www.orange1.eu

follow us   

