

NGBe

Permanent magnet
brushless servomotors

EN



ORANGE1
HOLDING

A dynamic, strong and ambitious Group:

Orange1 Holding is an international renown Group, one of the most important European manufacturers of single-phase and three-phase asynchronous electric motors. It has an annual capacity of more than 1 million motors and 5 million electric stators with an annual turnover of approx 200 million euro and more than 1200 workers in 11 production facilities. The group, established in 1971 by Leone Donazzan, chaired today by his son Armando Donazzan, is strongly focused on technological innovation, performance and customization to meet individual clients requirements. As a group of 13 companies it has a powerful advantage: the strength in numbers.



INDICE — INDEX

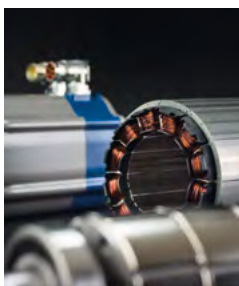

P. 04 Linea NGBe
— NGBe serie



P. 06 Caratteristiche principali
— Main features



P. 08 Soluzioni costruttive
— Constructive solutions



P. 13 Definizione dei parametri
— Parameter definition

143
123
96
mm

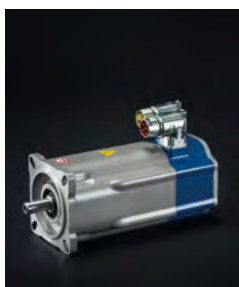

P. 14 NGBe96



P. 16 NGBe123



P. 18 NGBe143



P. 20 NGBe143 TEBC



P. 22 Accessori — Accessories



P. 26 Codice d'ordine
— Ordering code



NGBe

Nominal torque Nm
Nominal power kW



NGBe96

4,9 Nm
1,9 kW



NGBe123

11,9 Nm
2,7 kW



NGBe143

30 Nm
4,1 kW

NGBe143.TEBC

39 Nm
9,1 kW

SERVOMOTORI BRUSHLESS NGBE — Pensati per le esigenze sempre più estreme dell'automazione industriale che richiedono sistemi ad elevate prestazioni, miglior affidabilità e ridotta manutenzione. La serie NGBe è stata sviluppata utilizzando materiali di altissima qualità, nuovi dettagli estetici e funzionali sono stati introdotti per ottenere ingombri ridotti e una riduzione dei costi per il cliente.

THE NGBE BRUSHLESS RANGE — *The NGBe brushless servomotors are designed to meet the increasingly demanding needs of the automation industry, which require high-performance systems, greater reliability, and reduced maintenance. We used high-quality materials to develop the NGBe series. The new aesthetic and functional details introduced allowed us to reduce the overall dimensions, resulting in great savings for the customer.*

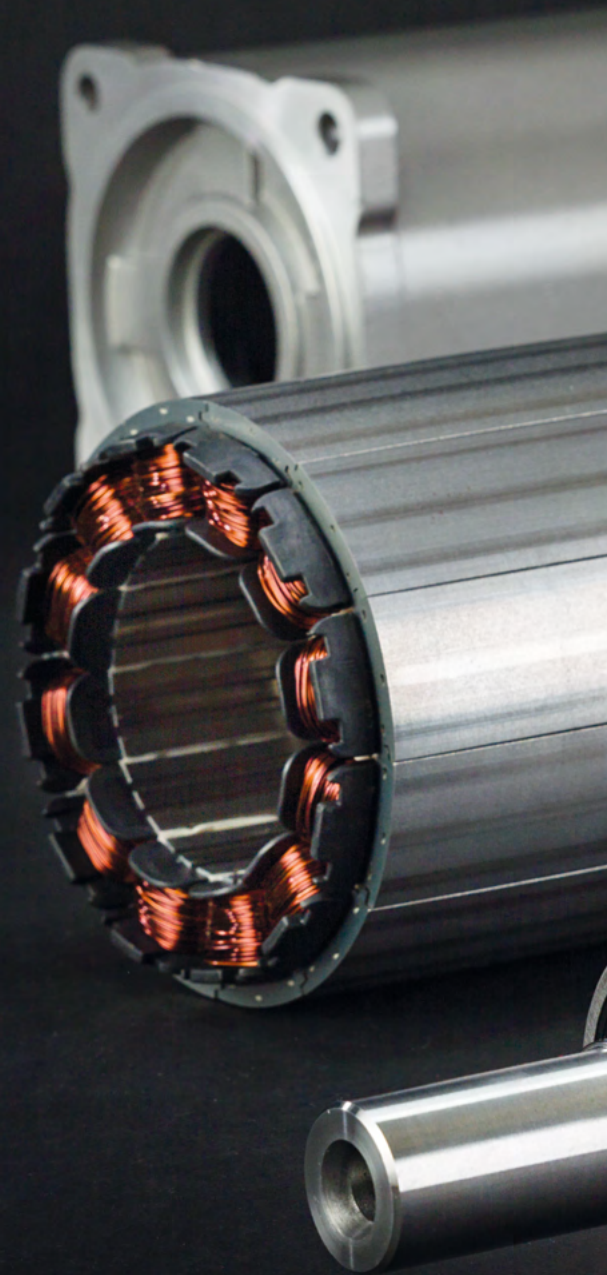

LINEA NGBe
NGBe SERIE

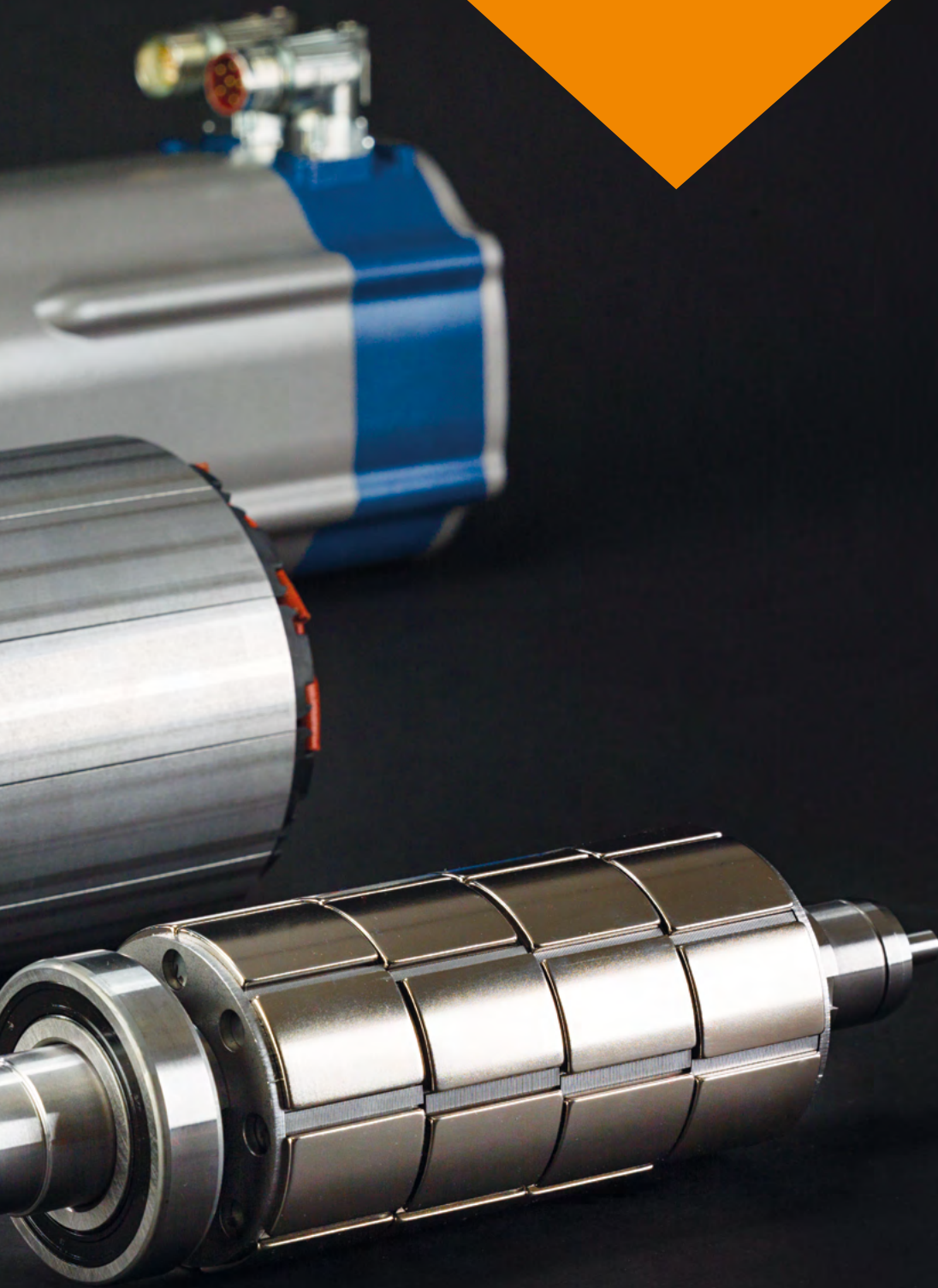

Caratteristiche principali — Main features

Affidabilità — Reliability

Magneti

Realizzati in terre rare **NeFeB**, rivestiti superficialmente per garantire elevate prestazioni e una protezione totale del magnete da fenomeni di ossidazione e corrosione vengono inoltre contenuti da un elemento tubolare.

Colle epossidiche

Dedicate all'incollaggio dei magneti al rotore per consentire un bloccaggio strutturale degli stessi, il riempimento dei giochi ed un'ottima protezione del magnete.

Cuscinetti

Di tipo a sfere con schermi, prelubrificati a vita. Il cuscinetto lato accoppiamento è stato scelto con un'adeguata capacità di carico radiale e sul lato opposto un cuscinetto speciale con grasso per alte temperature.

Magnets

*Magnets are made of **NeFeB** rare earth and are surface-coated to guarantee high performance and protect them against oxidation and corrosion. Moreover, they are contained in a tubular element.*

Epoxy glues

Used to glue the magnets to the rotor and lock them in place, fill in gaps, and protect the magnet.

Bearings

The shielded ball bearings are lubricated for life. The bearing on the coupling side has a suitable radial load capacity, whereas the special bearing on the opposite side has high-temperature grease.

Stator — The motors manufactured with the stator's monolithic structure, thus guaranteeing reliability and greater structural rigidity.



Modularità — Modularità

NGBe è progettato prevedendo un'uguale predisposizione meccanica per il montaggio di **4 differenti tipi di feedback motore**.

Il fissaggio del motore alle vostre macchine è agevole grazie all'**accesso diretto delle viti di fissaggio della flangia B5, V1 o V3**.

Le connessioni previste per i connettori M23 hanno la funzionalità di **aggancio rapido**, garantendo praticità anche nelle situazioni di impianti con difficile accessibilità.

*NGBe has an equal mechanical set-up for assembling **4 types of motor feedback**.*

*The motor can be easily fastened to your machines thanks to the **direct access to the B5, V1 or V3 flange fastening screws**.*

*The connections of the M23 connectors have the **quick coupling function**, which guarantees practicality, even when systems are difficult to access.*

Isolamento — Insulation

Tutta la **serie NGBe** è in **classe termica F**, pertanto la massima sovratemperatura dell'avvolgimento ammessa è di 105K (temperatura max ambiente 40°C).

L'avvolgimento dello statore è progettato con un **doppio isolamento elettrico**. Una prima impregnazione di vernice isolante seguita da un secondo riempimento con resina epossidica, in ambiente sottovuoto. Queste attenzioni garantiscono un eccellente grado di affidabilità dell'avvolgimento. Un'ottima soluzione per la protezione dello statore anche nei momenti di smontaggio per le operazioni di manutenzione.

*The entire **NGBe series** has a **class F thermal rating**; therefore, the maximum winding over-temperature permitted is of 105K (maximum room temperature: 40°C).*

*The winding of the stator is designed with **double electrical insulation**. It is first impregnated with an insulating paint and then it is filled with an epoxy resin in a vacuum environment. These details make the winding extremely reliable. An excellent solution to protect the stator during disassembly operations for maintenance purposes.*

References standard —
Our brushless servomotors comply with the IEC 60034 standard concerning rotating electrical machines. Therefore, they comply with the regulations of most of the EU Countries.



Soluzioni costruttive — Constructive solutions

Dummy slot

Sono previste delle nicchie sullo statore per produrre effetti sulla coppia simili a quelli dovuti alle cave, compensandoli.
The slots on the stator produce effects on the torque similar to those on the hollows, thereby compensating them.

Magnet phase shift

Nello stesso modulo di rotore i magneti sono collocati in posizione asimmetrica.
The magnets are placed in an asymmetric position in the same rotor module.

Stepped skewing

Posizione disallineata dei moduli del rotore
Misaligned position of the rotor modules.



“I servomotori **NGBe** sono progettati per ottenere una ridotta pendolazione di coppia, a favore di un’ottima rotondità di moto.”

“**NGBe** servomotors are designed to reduce torque oscillation and promote excellent rotation regularity.”



I NUOVI SERVOMOTORI
BRUSHLESS —

L'estetica del prodotto è il risultato di una grande attenzione al rapporto tra forma e funzionalità dei diversi componenti, soluzione capace di offrire un motore dalla forte riconoscibilità e con importanti dettagli funzionali.

THE NEW BRUSHLESS
MOTORS —

The aesthetics of the product is the result of our great attention to the relationship between the shape and functionality of different components to provide a highly recognizable motor with important functional details.



A photograph showing the disassembly of a motor on a blue workbench. The components are arranged from top to bottom: a stator core, a rotor assembly with copper windings, and a shaft with a pulley. Three individual stator poles are also shown to the right of the rotor. An orange arrow-shaped graphic points downwards from the top center, containing the text 'NGB evolution'.

NGB evolution

“L'attenzione che poniamo
nella scelta dei materiali,
ci consente di proporre
servomotori dalle ottime
performance, elevata robustezza
e massima affidabilità.”

“Our attention in choosing the materials
allows us to provide high-performance,
solid, and reliable servomotors.”

Definizione dei parametri — Parameters definition

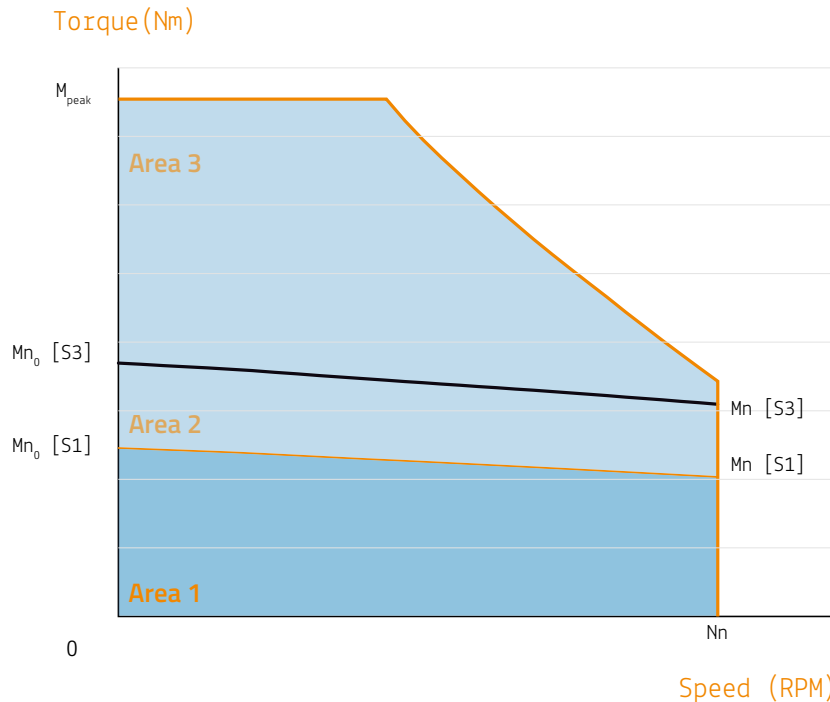

Reference graph for the parameters defined in this catalogue. For technical details not included in this document, refer to the NGBE series technical manual.

■ Area 1:

Area di funzione del motore in servizio continuativo S1 (CEI EN 60034-1); la curva $Mn_0 - Mn$ indica il declassamento della coppia continuativa erogabile in funzione della velocità.

■ Area 2:

Area di funzione del motore con servizio intermittente periodico S3-40% su periodo di un minuto (CEI EN 60034-1), con 40 secondi a carico costante e 60 secondi con motore a riposo; la curva $Mn_0 [S3] - Mn [S3]$ indica il declassamento della coppia quadratica media del ciclo erogabile, in funzione della velocità.

■ Area 3:

Area che descrive la coppia massima fornibile dal motore in relazione alle caratteristiche costruttive dello stesso $[M_{peak}]$ e in relazione alla massima tensione fornibile dal convertitore. Nella scelta del motore e avvolgimento si deve considerare la velocità fino a cui viene richiesta l'erogazione della coppia massima.

■ Area 1:

Function area of the motor in continuous running duty S1 (IEC EN 60034-1); the $Mn_0 - Mn$ curve indicates the de-rating of the continuous torque supplied according to speed.

■ Area 2:

Function area of the motor with periodic intermittent duty S3-40% over a period of one minute (IEC EN 60034-1), with 40 seconds at constant load and 60 seconds with motor in standby; the $Mn_0 [S3] - Mn [S3]$ curve indicates the de-rating of the cycle average square torque supplied, according to speed.

■ Area 3:

This area describes the maximum torque supplied by the motor in relation to its construction features $[M_{peak}]$ and maximum converter-supplied voltage. When choosing the motor and winding, it is important to consider the speed up to which the maximum torque has to be supplied.

Nominal Speed — It is the maximum speed of the motor. In this point, the maximum overload torque of the NGBE series guaranteed is $> Mn_0$.

NGBe96 – 3x360VRMS motor power supply

	code	Nominal speed Nn	Duty cycle S1			Duty cycle S3-40%, 1 min		Peak torque M _{peak}	Torque constant K _t	Inertia J	Weight m
			Stall torque Mn ₀	Nominal torque Mn	Stall current In ₀	Stall torque Mn ₀ [S3]	Nominal torque Mn [S3]				
NGBe96S	AL	3000 Rpm	2.2 Nm	1.9 Nm	2.2 A _{RMS}	3.2 Nm	2.9 Nm	6.6 Nm	0.99 Nm/A _{RMS}	1.3 kgcm ²	3.6 kg
NGBe96M	AI	3000 Rpm	3.6 Nm	3.2 Nm	2.8 A _{RMS}	5.5 Nm	4.9 Nm	10.8 Nm	1.30 Nm/A _{RMS}	2.3 kgcm ²	4.8 kg
NGBe96L	AH	3000 Rpm	4.9 Nm	4.2 Nm	3.7 A _{RMS}	7.5 Nm	6.5 Nm	14.7 Nm	1.34 Nm/A _{RMS}	3.4 kgcm ²	5.4 kg
NGBe96S	AM	5000 Rpm	2.2 Nm	1.8 Nm	3 A _{RMS}	3.2 Nm	2.7 Nm	6.6 Nm	0.71 Nm/A _{RMS}	1.3 kgcm ²	3.6 kg
NGBe96M	AF	5000 Rpm	3.6 Nm	2.8 Nm	4.6 A _{RMS}	5.5 Nm	4.3 Nm	10.8 Nm	0.79 Nm/A _{RMS}	2.3 kgcm ²	4.8 kg
NGBe96L	AD	5000 Rpm	4.9 Nm	3.5 Nm	5.9 A _{RMS}	7.5 Nm	5.5 Nm	14.7 Nm	0.83 Nm/A _{RMS}	3.4 kgcm ²	5.4 kg

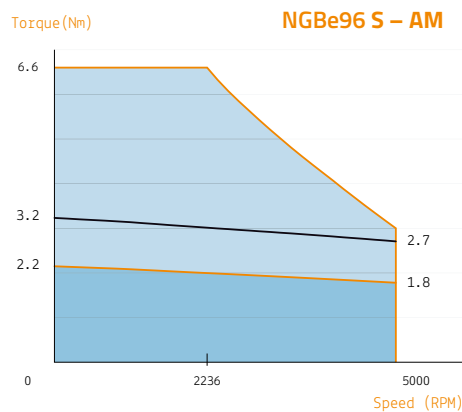
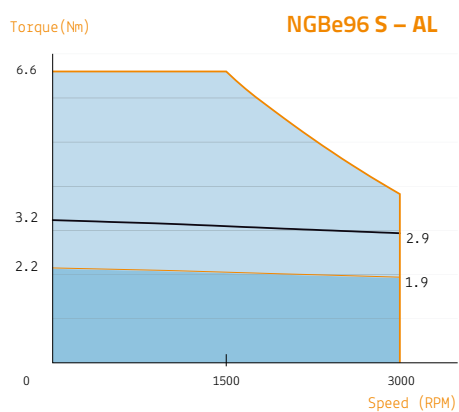

Torque constant —
The torque is proportional to the motor current

$$K_t = \frac{M_n \text{ [Nm]}}{I_n \text{ [A}_{RMS}]}$$

Others informations:
more data are available on technical manual of NGBe motor

Max torque —
S3 - 40% 1' —
S1 torque —

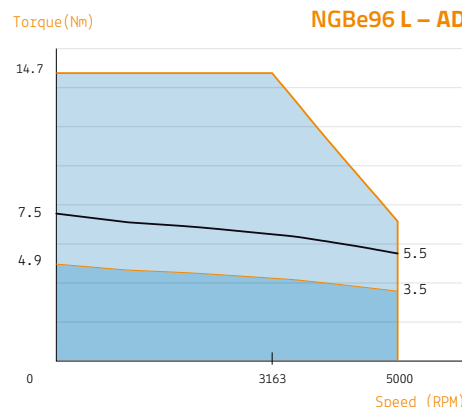
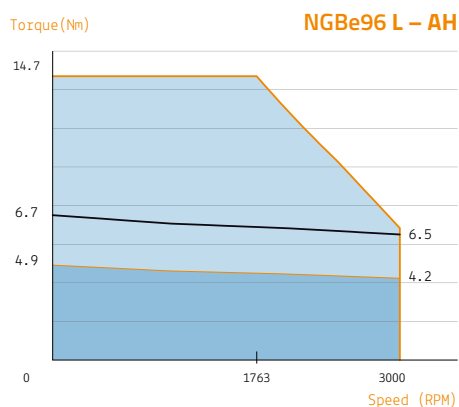
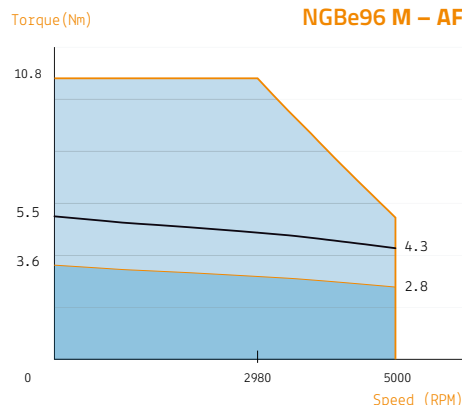
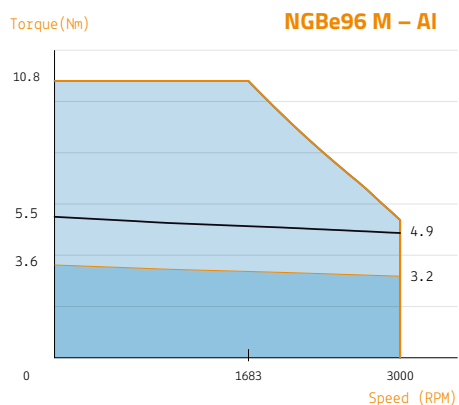

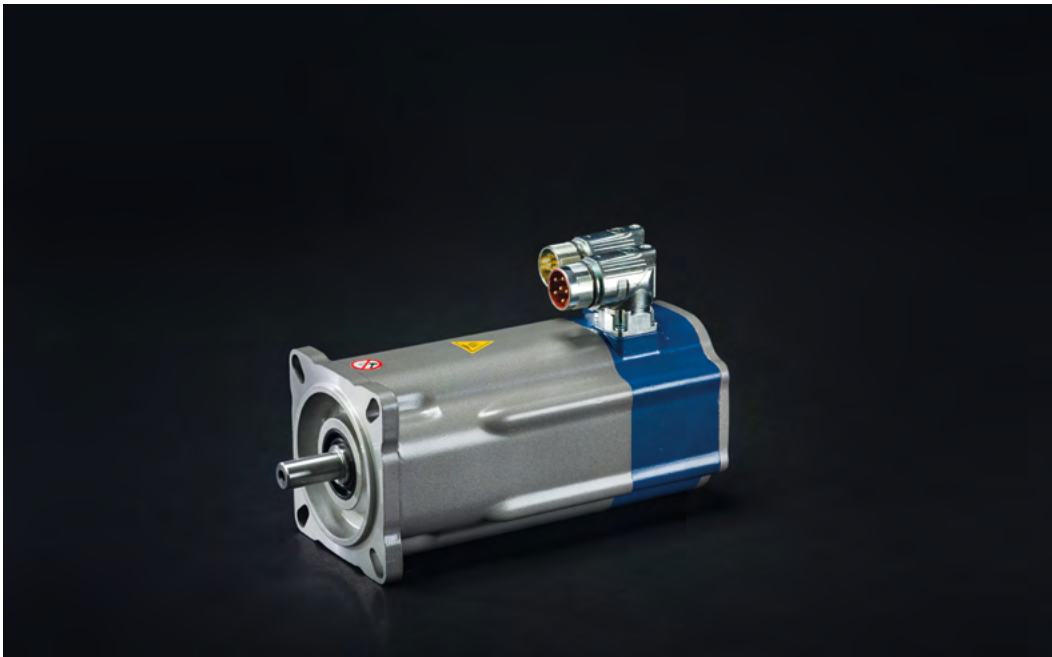

NGBe96 S	— B: 152mm
	L: 182mm
	LB: 232mm
NGBe96 M	— B: 179mm
	L: 209mm
	LB: 259mm
NGBe96 L	— B: 206mm
	L: 236mm
	LB: 286mm

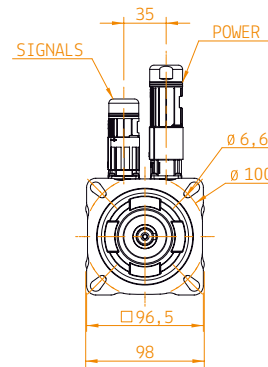
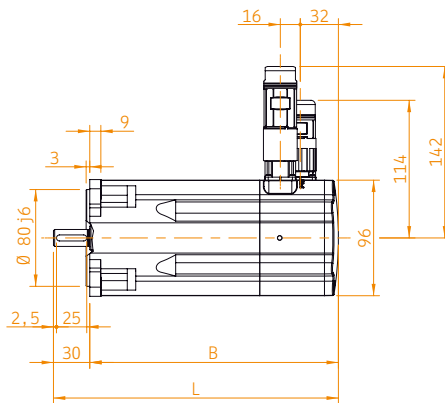

Version B —
Standard execution

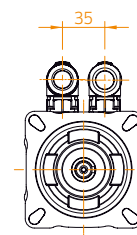
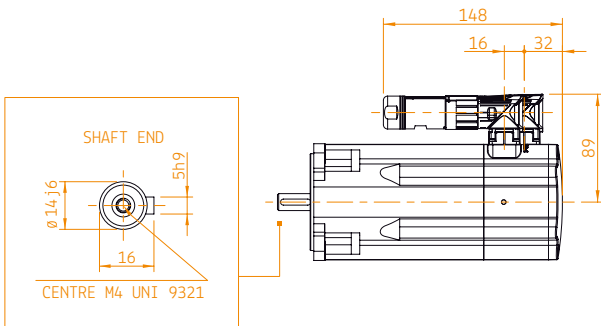

Version D —
Motor with rotatable
right angle connectors

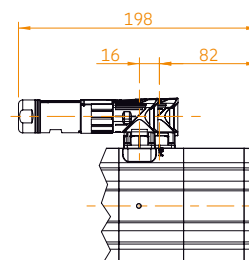
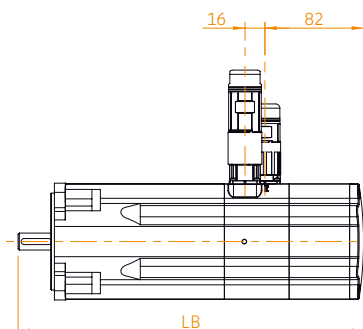

Motor with brake —
Left: Version B
Right: Version D

NGBe123 – 3x360VRMS motor power supply

	code	Nominal speed n_n	Duty cycle S1			Duty cycle S3-40%, 1 min		Peak torque M_{peak}	Torque constant K_t	Inertia J	Weight m
			Stall torque M_{n_0}	Nominal torque M_n	Stall current I_{n_0}	Stall torque $M_{n_0} [S3]$	Nominal torque $M_n [S3]$				
NGBe123S	AK	3000 Rpm	7.2 Nm	5.7 Nm	5.3 A _{RMS}	10.9 Nm	8.8 Nm	18 Nm	1.36 Nm/A _{RMS}	8.2 kgcm ²	6.7 kg
NGBe123M	AJ	3000 Rpm	9.6 Nm	7.2 Nm	6.5 A _{RMS}	14.8 Nm	11.3 Nm	25 Nm	1.48 Nm/A _{RMS}	12.1 kgcm ²	8.7 kg
NGBe123L	AG	3000 Rpm	11.9 Nm	8.5 Nm	8 A _{RMS}	18.4 Nm	13.4 Nm	36 Nm	1.49 Nm/A _{RMS}	16.1 kgcm ²	10.7 kg
NGBe123S	AI	5000 Rpm	7.2 Nm	4.5 Nm	8.7 A _{RMS}	10.9 Nm	7.0 Nm	18 Nm	0.83 Nm/A _{RMS}	8.2 kgcm ²	6.7 kg
NGBe123M	AF	5000 Rpm	9.6 Nm	4.9 Nm	10.5 A _{RMS}	14.8 Nm	7.8 Nm	25 Nm	0.91 Nm/A _{RMS}	12.1 kgcm ²	8.7 kg
NGBe123L	AD	5000 Rpm	11.9 Nm	4.5 Nm	13.2 A _{RMS}	18.4 Nm	7.3 Nm	36 Nm	0.90 Nm/A _{RMS}	16.1 kgcm ²	10.7 kg

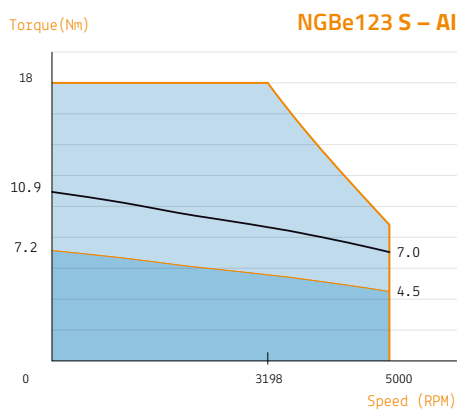
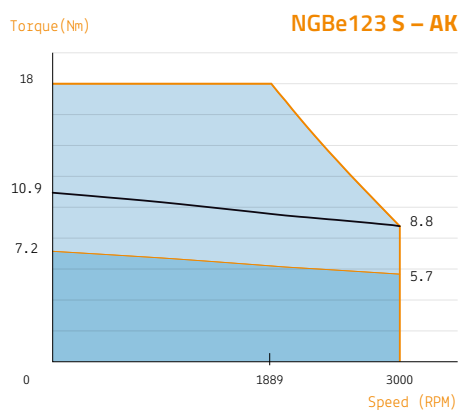

Torque constant —
The torque is proportional to the motor current

$$K_t = \frac{M_n \text{ [Nm]}}{I_n \text{ [A}_{RMS}]}$$

Others informations:
more data are available on technical manual of NGBe motor

Max torque —
S3 - 40% 1' —
S1 torque —

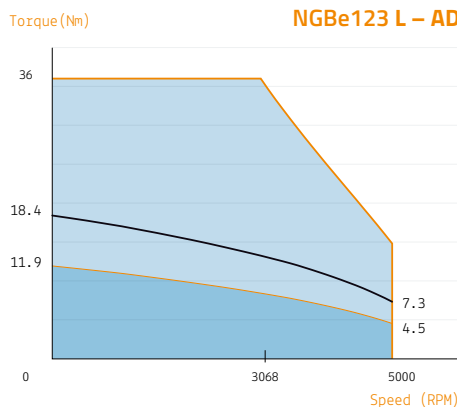
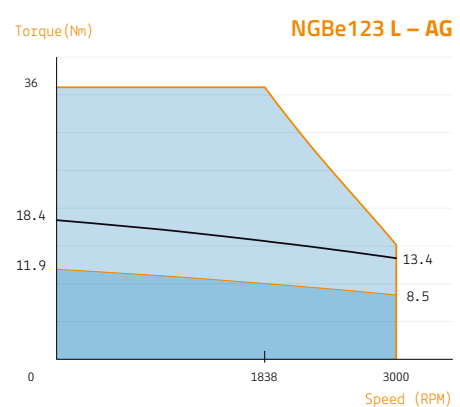
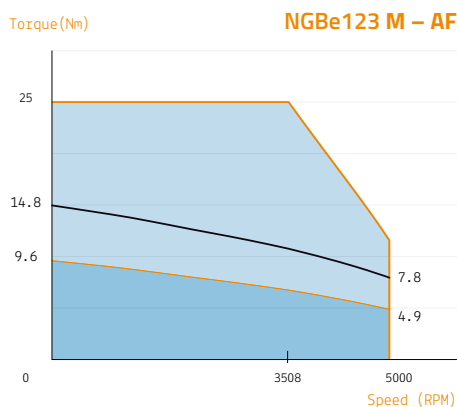
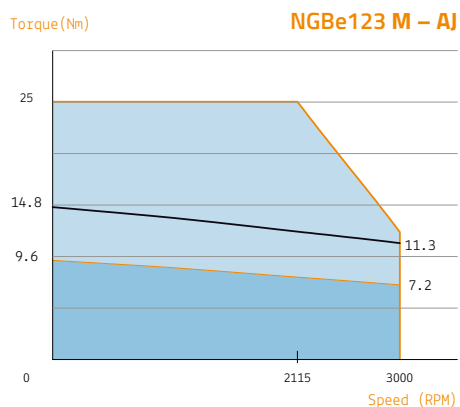



NGBe123S	— B: 183mm
	L: 233mm
	LB: 287mm
NGBe123M	— B: 210mm
	L: 260mm
	LB: 314mm
NGBe123L	— B: 236mm
	L: 286mm
	LB: 340mm

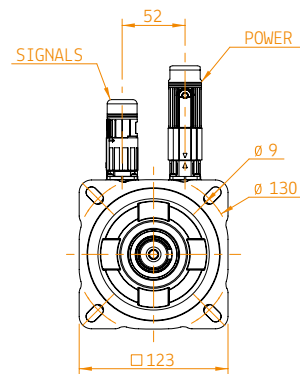
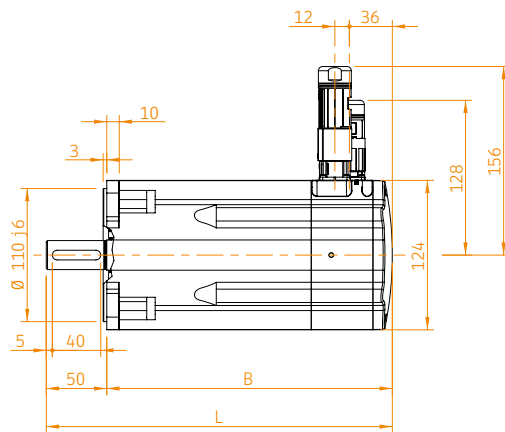

Version B —
Standard execution

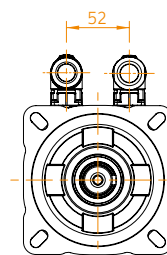
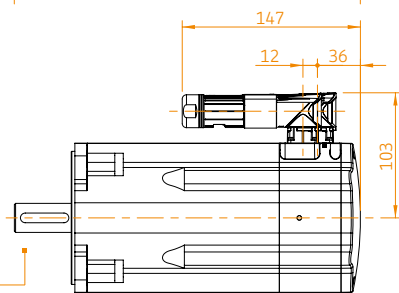

Version D —
Motor with rotatable
right angle connectors

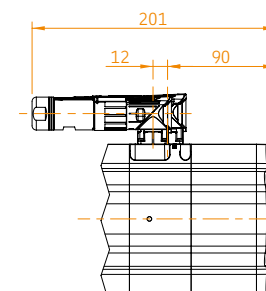
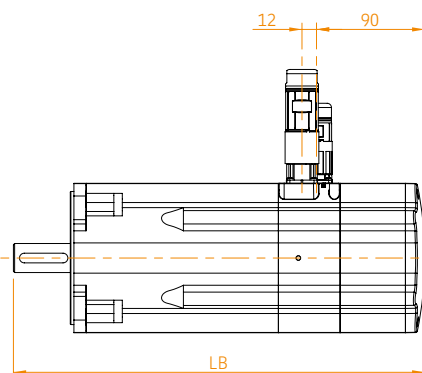
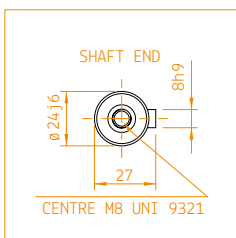

Motor with brake —
Left: Version B
Right: Version D

NGBe143 – 3x360VRMS motor power supply

	code	Nominal speed n_n	Duty cycle S1			Duty cycle S3-40%, 1 min		Peak torque M_{peak}	Torque constant K_t	Inertia J	Weight m
			Stall torque M_{n_0}	Nominal torque M_n	Stall current I_{n_0}	Stall torque $M_{n_0} [S3]$	Nominal torque $M_n [S3]$				
NGBe143S	BD	3000 Rpm	12.5 Nm	9.5 Nm	9.4 A _{RMS}	19.7 Nm	15.1 Nm	36.9 Nm	1.33 Nm/A _{RMS}	28 kgcm ²	8.8 kg
NGBe143M	BC	3000 Rpm	18.8 Nm	11.5 Nm	13.9 A _{RMS}	29.5 Nm	18.3 Nm	56.3 Nm	1.35 Nm/A _{RMS}	38 kgcm ²	12 kg
NGBe143L	AE	3000 Rpm	25 Nm	12.7 Nm	16.6 A _{RMS}	39.4 Nm	20.2 Nm	75 Nm	1.51 Nm/A _{RMS}	49 kgcm ²	15.1 kg
NGBe143P	AD	3000 Rpm	30 Nm	13.1 Nm	19.8 A _{RMS}	47.3 Nm	20.8 Nm	90 Nm	1.52 Nm/A _{RMS}	60 kgcm ²	18.2 kg

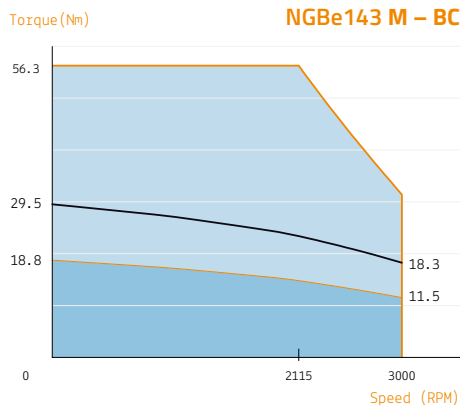
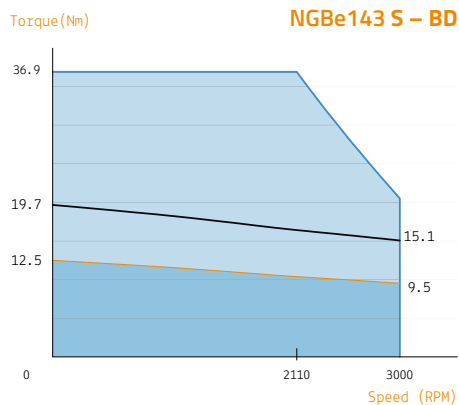

Torque constant —
The torque is proportional to the motor current

$$K_t = \frac{M_n \text{ [Nm]}}{I_n \text{ [A}_{RMS}]}$$

Others informations:
more data are available on technical manual of NGBe motor

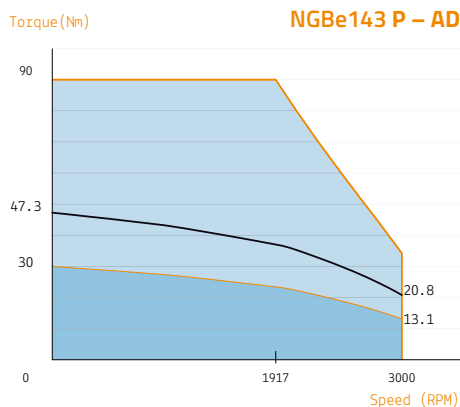
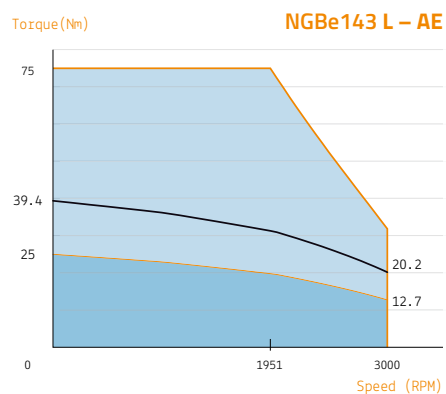

Max torque —
S3 - 40% 1' —
S1 torque —



NGBe143S	— B: 221mm
	L: 279mm
	LB: 344mm
NGBe143M	— B: 258mm
	L: 316mm
	LB: 381mm
NGBe143L	— B: 295mm
	L: 353mm
	LB: 418mm
NGBe143P	— B: 332mm
	L: 390mm
	LB: 455mm

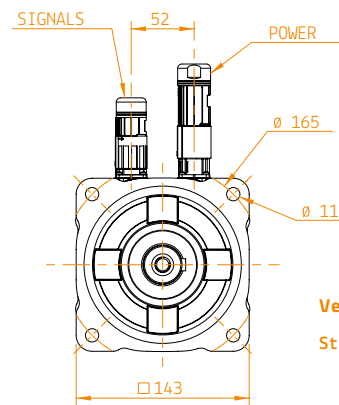
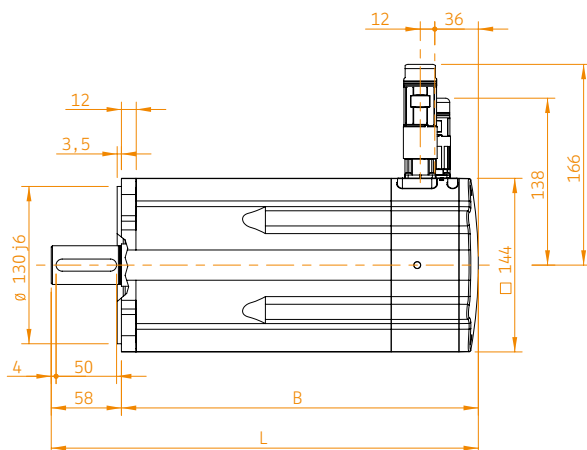

Version B —
Standard execution

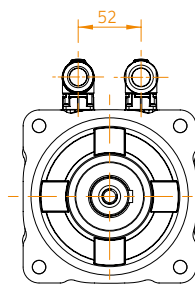
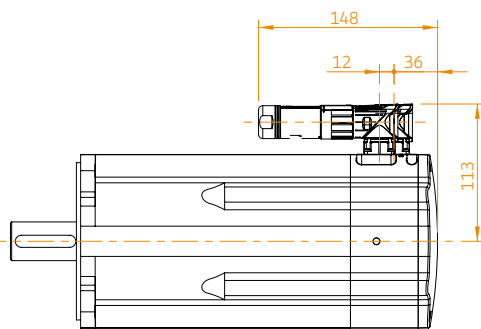

Version D —
Motor with rotatable
right angle connectors

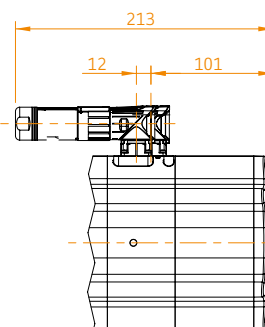
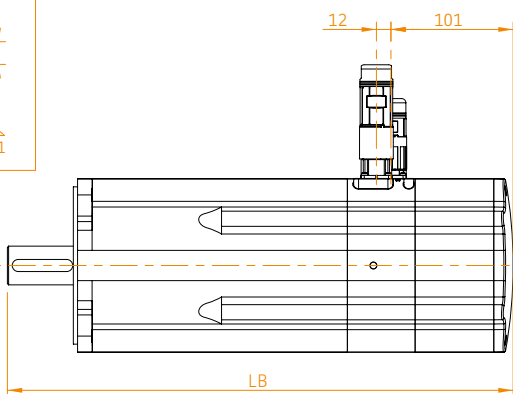
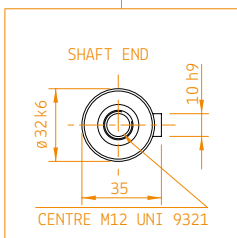

Motor with brake —
Left: Version B
Right: Version D

NGBe143 TEBC – 3x360VRMS motor power supply

	code	Nominal speed n_n	Duty cycle S1			Duty cycle S3-40%, 1 min		Peak torque M_{peak}	Torque constant K_t	Inertia J	Weight m
			Stall torque M_{n_0}	Nominal torque M_n	Stall current I_{n_0}	Stall torque $M_{n_0} [S3]$	Nominal torque $M_n [S3]$				
NGBe143S	BD	3000 Rpm	17.3 Nm	14.7 Nm	13 A _{RMS}	26.9 Nm	23.1 Nm	36.9 Nm	1.33 Nm/A _{RMS}	28 kgcm ²	11.8 kg
NGBe143M	BC	3000 Rpm	24.7 Nm	19.9 Nm	18.3 A _{RMS}	38.5 Nm	31.3 Nm	56.3 Nm	1.35 Nm/A _{RMS}	38 kgcm ²	15.3 kg
NGBe143L	AE	3000 Rpm	31.8 Nm	24.6 Nm	21.3 A _{RMS}	49.7 Nm	39.8 Nm	75 Nm	1.49 Nm/A _{RMS}	49 kgcm ²	18.7 kg
NGBe143P	AD*	3000 Rpm	38.7 Nm	29 Nm	25.5 A _{RMS}	60.5 Nm	46.3 Nm	90 Nm	1.52 Nm/A _{RMS}	60 kgcm ²	22.1 kg

* Only with terminal box solution

Totally Enclosed Blower Cooled

La versione ventilata del NGBe143: consente di raggiungere coppie continuative più elevate in tutto il range di velocità. Si presta ad applicazioni dove il ciclo macchina è particolarmente oneroso.

The NGBe143 ventilated version reaches higher continuous torque in the entire speed range. It is suitable for applications where machine cycle is particularly heavy.

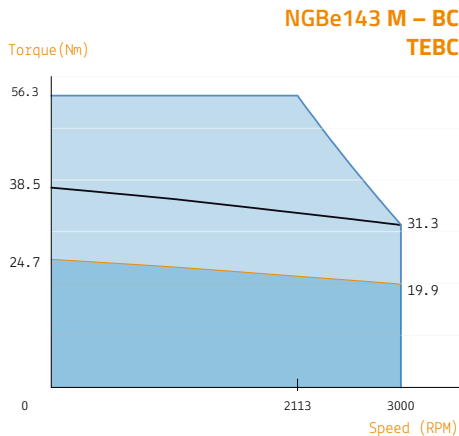
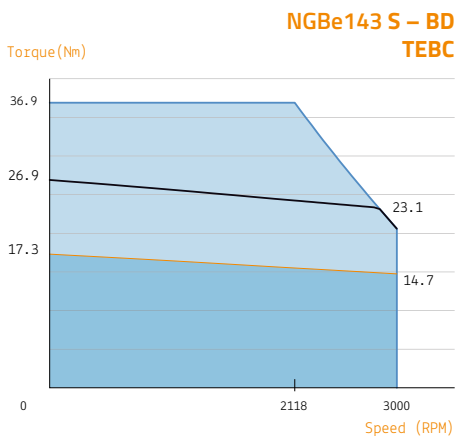

Torque constant —
The torque is proportional to the motor current

$$K_t = \frac{M_n \text{ [Nm]}}{I_n \text{ [A}_{RMS}]}$$

Others informations:
more data are available on technical manual of NGBe motor

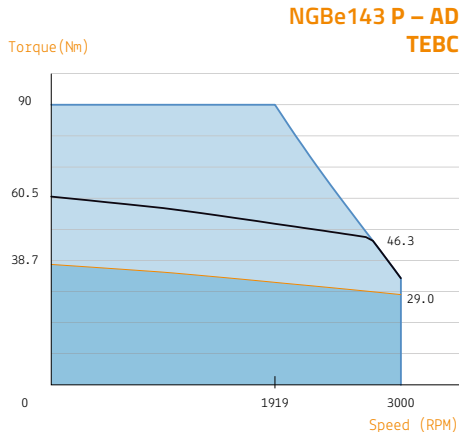
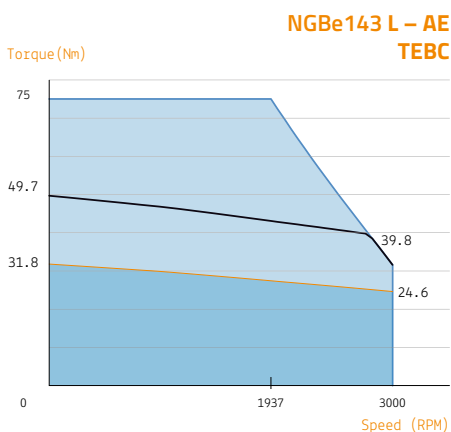

Max torque —
S3 - 40% 1' —
S1 torque —



NGBe143S — B: 332mm	NGBe143L — B: 406mm
L: 390mm	L: 464mm
LB: 577mm	LB: 529mm
NGBe143M — B: 369mm	NGBe143P — B: 443mm
L: 427mm	L: 501mm
LB: 492mm	LB: 566mm

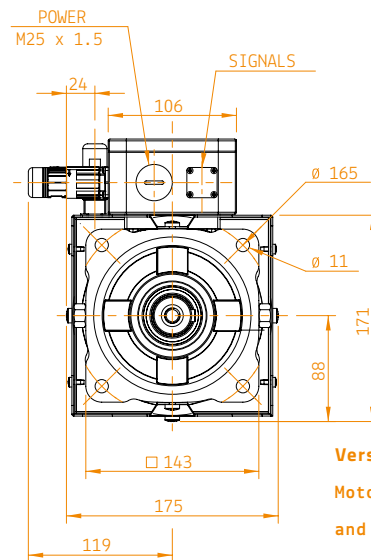
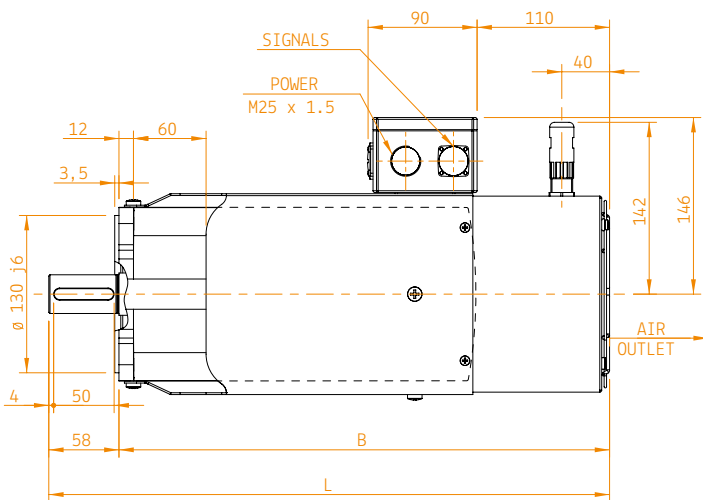

Version S —
 Motor with terminal box
 and electrofan:
 alimentato a 230Vac
 50/50Hz su connettore
 industriale M16 3 pins.

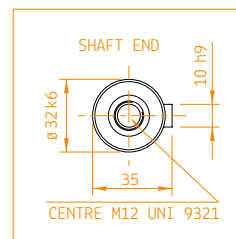
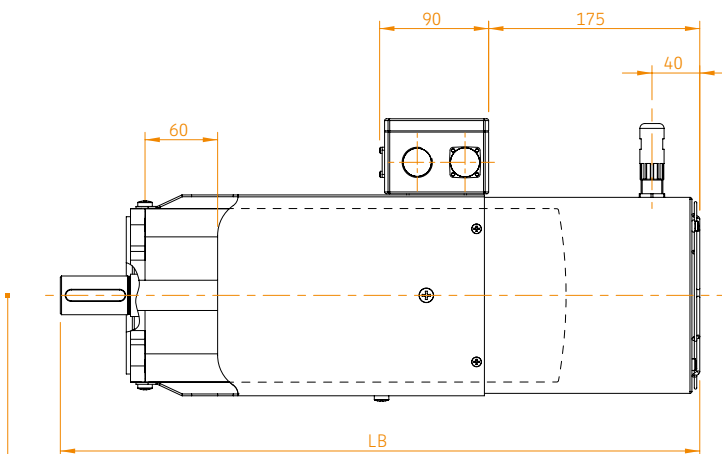

Motor with brake —
 For dimensions of motors
 with B and D connector
 version,
 Please contact
 Magnetic Motors s.r.l.

**ACCESSORI
ACCESSORIES**



Connessioni motore — Motor connection

Sistema di feedback del motore — Motor feedback system

Il motore è fornito completo di resolver o di encoder, alloggiato nello scudo posteriore per la protezione contro gli urti accidentali. Sono disponibili i seguenti tipi:

- **Resolver 2 poles:** Sine-Cosine wave – 2 poles – 0.5 ratio transformation
- **Encoder TTL + Hall S., Abs. singleturn:** incremental signal TTL 2048 ppr (max 150 kHz) – 5 Vdc Line driver – Commutation signals – Zero pulse
- **Encoder Sin Cos Abs. singleturn:** incremental signal sinusoidale 2048 ppr – 1 Vpp signal SinCos + zero pulse – 1 period absolute waves/rev. – 5Vdc
- **Encoder BiSS Abs. multiturn:** absolute multiturn BiSS interface – incremental sinusoidal signal 2048 ppr – 19 bit singleturn + 12 multiturn – 5Vdc

Altri encoder (Endat, Hyperface ..) o sole predisposizioni sono possibili su richiesta.

The motor is provided with a resolver or encoder housed in the rear shield to protect it against accidental impacts.

The following types are available:

- **2-pole resolver:** Sine-Cosine wave – 2 poles – 0.5 transformation ratio
- **Encoder TTL + Hall S., Abs. singleturn:** incremental signal TTL 1024%2048 ppr (max 150 kHz) – 5 Vdc Line driver – Commutation signals – Zero pulse
- **Encoder Sin Cos Abs. single turn:** incremental signal sinusoidale 2048 ppr – 1 Vpp signal SinCos + zero pulse – 1 period absolute waves/rev. – 5Vdc
- **Encoder BiSS Abs. multi-turn:** absolute multiturn BiSS interface – incremental sinusoidal signal 2048 ppr – 19 bit singleturn + 12 multiturn – 5Vdc

Other encoders (Endat, Hyperface, etc.) or other set-ups are available upon request.

Freno — Brake

Su richiesta è disponibile il motore completo di freno di stazionamento che si inserisce in mancanza di alimentazione (freno negativo). Tale freno è previsto per mantenere bloccato l'asse e deve essere inserito a velocità prossima a zero: le operazioni di frenatura del motore in velocità sono infatti delle frenature elettriche effettuate tramite l'inverter e non svolte o assistite dal freno. L'alimentazione a 24 Vdc è cablata sul connettore di potenza.

The motor complete with holding and/or emergency brake, which engages in case of power failure (negative brake), is available upon request. This brake keeps the axis blocked and must be engaged when speed is close to zero. At a certain speed, the motor brakes electrically via an inverter and not via the brake, which does not even assist during this operation. The 24 Vdc power supply is wired to the power connector.

	Nominal torque @20°C M _n	Stall torque @100°C M _{stat}	Inertia *ΔJ	Weight *Δm
NGBe96	4.5 Nm	4.0 Nm	0.12 kgcm ²	0.3 kg
NGBe123	18 Nm	15 Nm	1.66 kgcm ²	0.9 kg
NGBe143	36 Nm	32 Nm	5.56 kgcm ²	1.6 kg

* Aggiuntiva a quella del motore

Protezione termica — Power connection

I servomotori possono essere forniti con uno dei seguenti tipi di sensore termico:
Termoresistenza tipo KTY 84-130
Termocontatto N.C. klixon

*The servo motors can be supplied with one of the following types of thermal sensor:
Resistance thermometer type KTY 84-130
Temperature Switch N.C. klixon*

Verniciatura — Painting

I motori vengono forniti verniciati bi-colore blu RAL 5000 + grigio RAL 9007 con vernici a polvere che assicurano elevate caratteristiche meccaniche (durezza, elasticità) e una buona finitura delle superfici del motore. A richiesta possiamo realizzare una verniciatura smalto monocoloro su specifiche a richiesta del cliente.

The motors are painted with two colours, blue RAL 5000 and grey RAL 9007, with powder paints that ensure high mechanical features (hardness, elasticity) and a good finish of the motor's surfaces. Single-colour enamel paint available upon request.

Anello paraolio — Seal ring

Tutti i motori possono essere equipaggiati con anello di tenuta paraolio con molla per applicazioni dove è previsto il bagno d'olio, mentre su richiesta è possibile fornire anche la versione solo per tenuta IP65 sull'albero.

All motors can be equipped with oil seal ring with a spring for applications requiring oil bath. The specific version for an IP65 seal on the shaft can be supplied upon request.

Inerzia supplementare — Ring seal

Su richiesta è possibile prevedere un'inerzia aggiuntiva per migliorare il controllo del motore (opzione disponibile solo nella versione senza freno).

Extra inertia can be added upon request to improve motor control (option available only in the brakeless version).

	Additional inertia ΔJ	Additional weight Δm
NGBe96	+ 1.1 kgcm ²	+ 0.4 kg
NGBe123	+ 7.5 kgcm ²	+ 1.0 kg
NGBe143	+ 22.8 kgcm ²	+ 1.9 kg

Conessioni motore — Motor connection

Conessioni di potenza 6 pins — Power connection 6 pins

Conessione di potenza
+ connessione freno di stazionamento.

*Power connections
+ parking brake connection.*

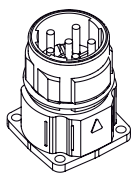

connector M23 —
Straight or adjustable
to 90 °, fitted for
both quick-coupling for
in thread engagement.

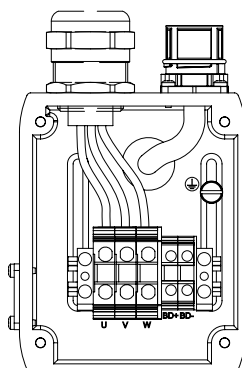
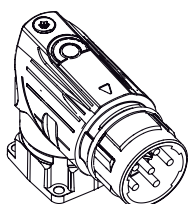

Terminal adjustable box
2 positions —
Available only
on NGBe143

Conessioni di segnale 17 pins — Signal connection 17 pins

Conessione trasduttore velocità/posizione. *Speed/position transducer connection.*

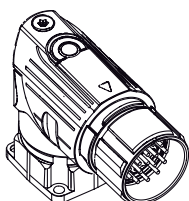
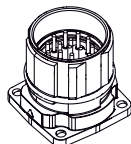

connector M23 —
Straight or adjustable
to 90 °, fitted for
both quick-coupling for
in thread engagement.

Connettori volanti opzionali — Optional mobile connectors

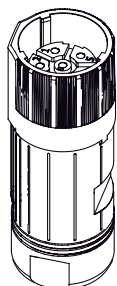

Free connector M23 —
6 pins power connector,
quick coupling.

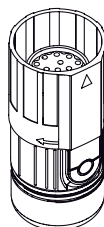

Free connector M23 —
17 pins signal connector,
quick coupling.

Cavi opzionali — Optional cables

A richiesta possiamo fornire cavi di alimentazione e di controllo servomotore della lunghezza desiderata completi di connettore ad innesto rapido lato motore.

Servomotor control and power cables (of the required length) complete with quick coupling connector on the motor side can be supplied upon request.

Codice di ordinazione — Ordering code

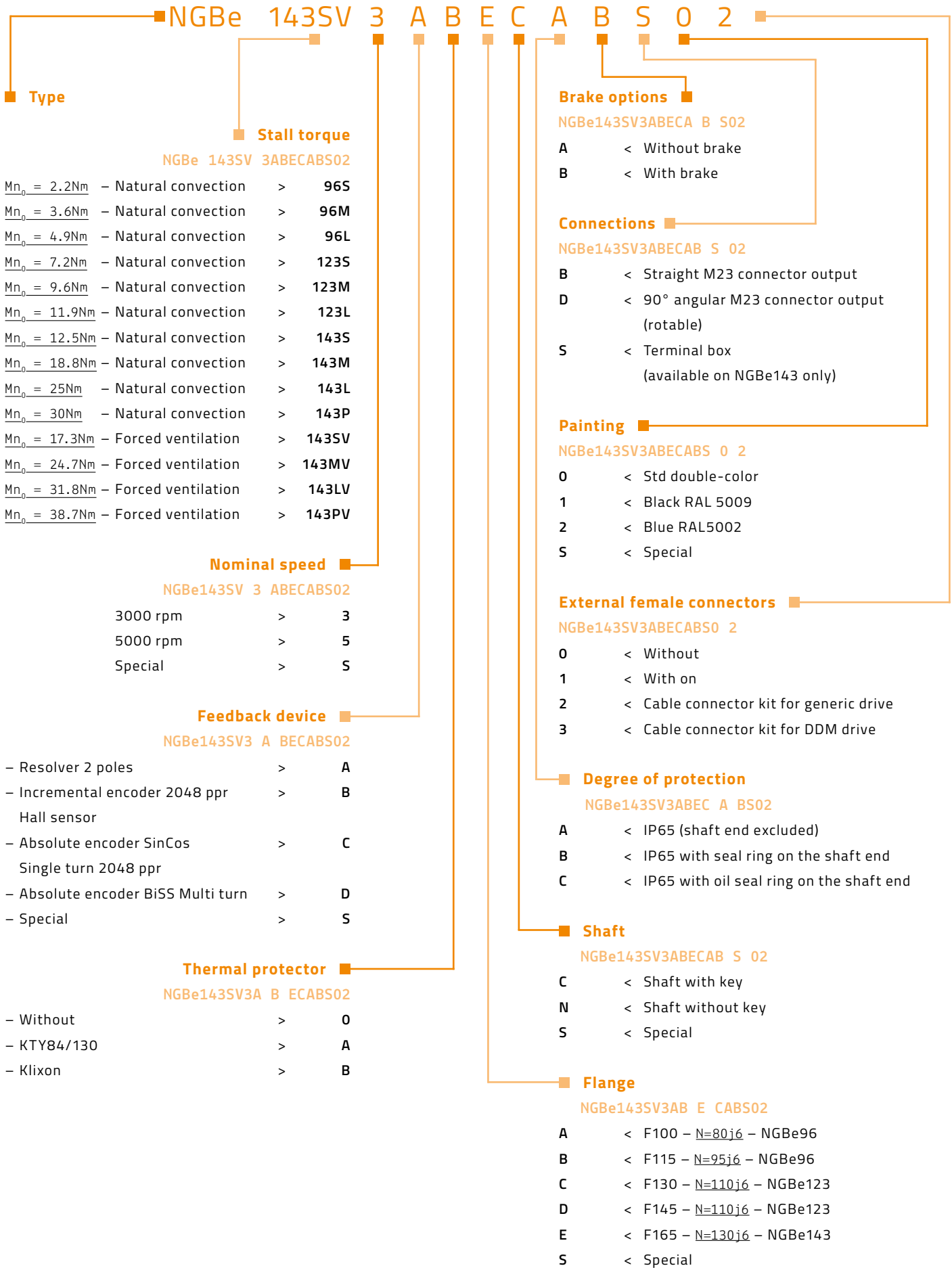



ORANGE1
HOLDING

Magnetic Motor S.r.l.
Via del Lavoro 7
Montebello Vicentino
36054 - (VI) Italy
T. +39 0444 649399
F. +39 0444 440495

info@magnetic.it
Pec magneticmotorsrl@legalmail.it
www.magnetic.it

info@orange1.eu
www.orange1.eu

follow us   

#02 - 10/2017

