



INCREASED
SAFETY MOTORS

26b

— 1 ORANGE®



elprom





Motors for Hazardous Areas

elprom





CONTENTS

1. TOLERANCES AND STANDARDS OF REFERENCE	4
1.1 Mechanical and Electrical tolerances	4
1.2 Standards of reference	4
2. GUIDE TO MOTOR CHOICE	5
3. GENERAL INFORMATIONS.....	8
3.1 Range of motors	8
3.2 Testing and certificates	9
3.3 Main features	9
3.4 Main Options.....	10
3.5 Motors identification	11
4. TERMINAL BOX, CABLE ENTRIES AND CONNECTIONS.....	12
5. MECHANICAL CHARACTERISTICS.....	13
5.1 Radial and axial forces on the shaft end	14
6. ELECTRICAL DATA	15
6.1 Motors for ATEX Zones 1, 21 (Increased safety 'Ex e', protection by enclosure 'tb' IIIC)	15
6.2 Motors for ATEX Zones 2, 22 (Non-sparking 'Ex nA', protection by enclosure 'tc' IIIB)	18
7. OVERALL DIMENSIONS	21
8. SPARE PARTS, OVERHAULS AND REPAIRS	22
8.1 Personnel qualification.....	22
8.2 Spare parts	22



1. Tolerances and standards of reference

1.1 Mechanical and Electrical tolerances

Symbol	Description	Tolerance	
A	Distance between centre-lines of fixing holes (end view)	± 1 mm	
AB	Overall dimensions across the feet (end view)	+ 2 %	
AC	Diameter of the motor (without terminal box)	+ 2 %	
B	Distance between centre-lines of fixing holes (side view)	± 1 mm	
C - CA	Distance from the shaft end shoulder to the centre-line of nearest mounting holes in the feet	± 3 mm	
D - DA	Diameter of the shaft extension.	\varnothing 11 – 28 \varnothing 32 – 48 \varnothing ≥ 55	j6 k6 m6
E - EA	Length of the shaft extension from the shoulder	\varnothing < 55 mm \varnothing > 60 mm	- 0,3 mm + 0,5 mm
F - FA	Width of the keyway of the shaft extension	h9	
GA - GC	Distance from the top of the key to the opposite surface of the shaft extension	+ 0,2 mm	
H	Distance between the centre-line of the shaft to the bottom of the feet	H ≤ 250 H ≥ 280	- 0,5 mm - 1 mm
HD	Distance from the top of the terminal box and to the bottom of the feet	+ 2 %	
K	Diameter of the holes or width of the slots in the feet of the motor	+ 3 %	
L	Overall length of the motor with a single shaft extension	+ 1 %	
M	Pitch circle diameter of the fixing holes	± 0,8 mm	
N	Diameter of the spigot	\varnothing < 230 \varnothing ≥ 250	j6 h6
P	Outside diameter of the flange	± 1 mm	
R	Distance from the shaft shoulder to the mounting surface of the flange	± 3 mm	
S	Diameter of the fixing holes in the mounting flange or nominal diameter of thread	+ 3 %	
	Distance from the shaft shoulder to the mounting surface of the flange with locked bearing	± 0,5 mm	
	Mass of the motor	- 5 a + 10 %	
	Nominal voltage, V_N	±5%	
	Efficiency, η	-15% of (1- η)	
	Power factor, $\cos \varphi$	-1/6 of (1-cos φ) min 0.02, max 0.07	
	Slip (rpm) (full load and nominal ambient temperature), P_N	±20% if $P_N \geq 1$ kW ±30% if $P_N < 1$ kW	
	Locked rotor current, I_A	+20%	
	Locked rotor torque, M_A	-15% +25%	
	Breakdown torque, M_{max}	-10% con $M_{max}/M_N \geq 1.6$	
	Minimum torque, M_{min}	-15%	
	Moment of Inertia, J	±10%	
	Sound intensity level (sound pressure) L_{pFA}	+3 dBA	

1.2 Standards of reference

Title	EU CENELEC	International IEC
Rotating electrical machines Part 1: Rating and performance	EN 60034-1	IEC 60034-1
Rotating electrical machines Part 2-1: Standard methods for determining losses and efficiency from tests (excluding machines for traction vehicles)	EN 60034-2	IEC 60034-2
Rotating electrical machines. Part 5: Degrees of protection provided by the integral design of rotating electrical machines (IP code). Classification	EN 60034-5	IEC 60034-5
Rotating electrical machines Part 6: Methods of cooling (IC Code)	EN 60034 -6	IEC 60034 -6
Rotating electrical machines Part 7: Classification of types of construction, mounting arrangements and terminal box position (IM Code)	EN 60034-7	IEC 60034-7
Rotating electrical machines Part 9: Noise limits	EN 60034-9	IEC 60034-9
Rotating electrical machines Part 12: Starting performance of single-speed three-phase cage induction motors	EN 60034-12	IEC 60034-12
Rotating electrical machines Part 14: Mechanical vibration of certain machines with shaft heights 56 mm and higher - Measurement, evaluation and limits of vibration severity	EN 60034-14	IEC 60034-14
General purpose three-phase induction motors having standard dimensions and outputs. Frame numbers 56 to 315 and flange numbers 65 to 740	EN 50347	IEC 60072-1
Degrees of protection provided by enclosures (IP Code)	EN 60259	IEC 60529
Electrical apparatus for explosive gas atmospheres Part 0: General requirements	EN 60079-0	IEC 60079-0
Electrical apparatus for explosive gas atmospheres Part 15: Type of protection "n"	EN 60079-15	IEC 60079-15
Electrical apparatus for explosive gas atmospheres Part 7: Increased safety "e"	EN 60079-7	IEC 60079-7
Electrical apparatus for use in the presence of combustible dust Part 0: General requirements	EN 61241-0	IEC 61241-0
Electrical apparatus for use in the presence of combustible dust Part 1: Protection by enclosures "tD"	EN 61241-1	IEC 61241-1



2. Guide to motor choice



First step is the classification of hazardous places in zones. The end user shall classify the hazardous areas under his own responsibility.

Directive 1999/92/EC provides information regarding 'Classification of places where explosive atmosphere may occur'. The corresponding standards of reference are EN 60079-10 for gas and EN 61241-10 for dust.

Here below we give you a synthetic step by step guide to the choice of the motors. We will highlight all the characteristics of our motors.

Electrical apparatus ATEX marking							
Zone Classification (presence of explosive atmosphere)		(1) Group	(2) Category	(3) Type of protection	(4) Gas group Dust group	IP Degree	(5) GAS Temperature class (6) DUST Surface temperature
GAS	0	Present continuously or for long period	II	1G	Electrical apparatus not allowed		
	1	Occur in normal operation occasionally	II	2G	Ex eb 'increased safety' Ex db 'flameproof enclosure'	IP54 -	T1=450°C T2=300°C T3=200°C T4=135°C T5=100°C T6=85°C
	2	Rarely occur in normal operation and for short period	II	3G	Ex nAc 'non sparking'	IP54	T1=450°C T2=300°C T3=200°C T4=135°C T5=100°C T6=85°C
POLVERI	20	Present continuously or for long period	II	1D	Electrical apparatus not allowed		
	21	Occur in normal operation occasionally	II	2D	Ex tb 'protection by enclosure t'	IP6X	T125°C
	22	Rarely occur in normal operation and for short period	II	3D	Ex tc 'protection by enclosure t'	IP5X	

(1) **Group II:** comprises equipment intended for use in other places likely to become endangered by explosive atmospheres (surface plants different from mines).

(2) Group II is sub-divided into 3 categories:
 Category 1: very high level of protection
Category 2: high level of protection
 Category 3: normal level of protection

G explosive atmosphere consisting of a mixture with air and flammable substances in the form of gas, vapour or mist
 D explosive atmosphere in the form of a cloud of combustible dust in air

(3) Elprom motors J-K series can have the following types of protection:
Ex eb Increased safety (GAS)
Ex nAc Non-sparking (GAS)
Ex tb, Ex tc protection by enclosure 'tD' (DUST)

(4) GAS group	IIC	Hydrogen, Acetylene, carbon disulfide
	IIB	Diethyl ether, Ethylene etc.
	IIA	Propane, Butane, pentane, natural gas etc.
DUST group	IIIC	Conductive dust
	IIIB	Non-conductive dust
	IIIA	Combustible fibers

(5) (GAS) In function of their maximum surface temperature the motors are classified in a **temperature class**.

(6) (DUST) The **surface temperature** must be less or equal than the minimum value between Tmax1 e Tmax2 where:

$$T_{max1} = 2/3 \cdot T_{cl} \quad \text{with } T_{cl} \text{ ignition temperature in } ^\circ\text{C} \text{ of the dust cloud.}$$



Increased safety design, Ex e

The design of this motor type prevents the occurrence of sparks, arcs or hot spots in service (including starting and locked rotor situation), that could reach the self-ignition temperature of the surrounding, potentially explosive atmosphere, in all inner and outer parts of the machine. This is ensured by applying constructional or dimensional provisions that mainly concern:

- specified minimum values for creepage distances and clearances
- use of tracking-proof isolating materials
- suppression of sharp angles where static electrical loads could build-up
- ensuring electrical and mechanical assemblies are tightly secured
- minimum backlash values between stationary and rotating parts (e.g., air gap, ventilation, etc.)
- temperature-rise limits, taking into account locked rotor and normal operation under the most adverse thermal conditions (in case of the worst voltage conditions).

Thermal protection

- 1) When intended for use with a current-dependent device to protect against exceeding the limiting temperature, the starting current ratio I_A/I_N and the time t_E shall be determined and marked (t_E shall not be less than 5sec while I_A/I_N shall not exceed 10). So to prevent from exceeding the limit temperature the protection devices must trip within the time t_E .
- 2) When intended for use with winding temperature sensors associated with protective devices to protect against the occurrence of non-permissible temperatures, the starting current ratio I_A/I_N shall be determined and marked. Time t_E is not required to be determined and marked.

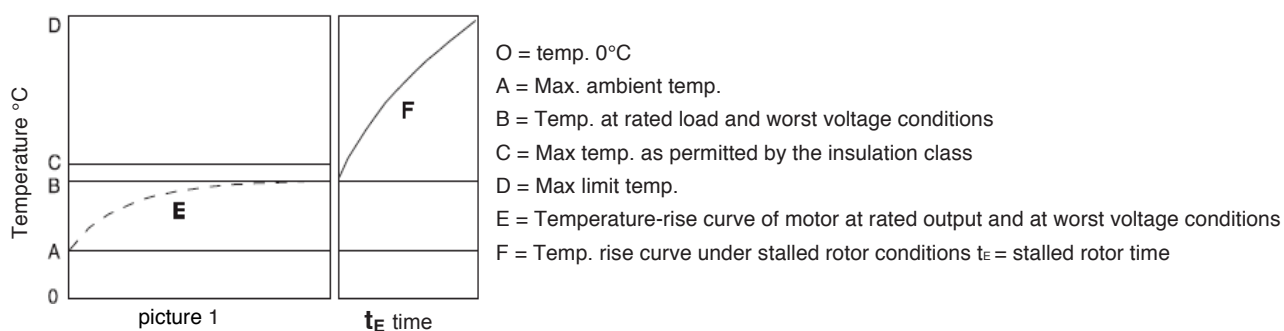

Non-sparking design, Ex nA

This type of protection is allowed to be used in the hazardous area corresponding to zone 2.

This design is also known as 'Non-sparking' type as the motor must be designed in such a way that no sparks can occur in normal operation, used within the ratings specified by the manufacturer, which excludes thermal requirements due to starting or accidental stalling.

Protection by enclosures "t"

This protection prevents any explosion transmission of dust because:

the IP protection avoid to the dust to go inside the moto, the maximum surface temperature outside the motor must not exceed the limit temperature, no sparks must occur outside the motor enclosure.



GAS- Main inflammable substances							
Inflammable substance	Group of GAS	temperature of ignition	Temp. Class	Inflammable substance	Group of GAS	temperature of ignition	Temp. Class
2-Methylpentane	IIA	300	T2	Ethyl formate	IIA	440	T2
Amyl acetate	IIA	360	T2	Methyl formate	IIA	450	T1
Butyl-n acetate	IIA	425	T2	Natural gas	IIA	482	T1
Ethyl acetate	IIA	426	T2	Isobutane	IIA	460	T1
Isobutyl acetate	IIA	420	T2	Isoheptane	IIA	220	T3
Methyl acetate	IIA	502	T1	Isohexane	IIA	264	T3
Propil acetate	IIA	430	T2	Isooctane	IIA	410	T2
Vinyl acetate	IIA	425	T2	Isoprene	IIA	220	T3
Acetone	IIA	465	T1	Methane	IIA	537	T1
Methanol	IIA	464	T1	Methylcyclopentane	IIA	258	T3
Brome thane	IIA	511	T1	Methylamine	IIA	430	T2
Butane	IIA	287	T3	Methylmetacrylate	IIA	430	T2
Butane - 1	IIA	384	T2	Paraldehyde	IIA	239	T3
Butane - 2	IIA	325	T2	Pentane	IIA	258	T3
Cycloexano	IIA	259	T3	Pyridine	IIA	483	T1
Cycloexanol	IIA	300	T2	Propane	IIA	470	T1
Cyclohexanone	IIA	419	T2	Propylamine	IIA	318	T2
Cyclohexene	IIA	244	T3	Propylbenzene	IIA	450	T1
Cyclopropane	IIA	498	T1	Propylene	IIA	455	T1
Cymene (p)	IIA	436	T2	Styrene	IIA	490	T1
Chloro-benzene	IIA	637	T1	Toluene	IIA	480	T1
Acetyl chloride	IIA	390	T2	m-Xylene	IIA	522	T1
Allyl chloride	IIA	390	T2	o-Xylene	IIA	464	T1
Chlorbutane	IIA	240	T3	p-Xylene	IIA	528	T1
Chloroethane	IIA	495	T1	1,2 Butadiene	IIB	430	T2
Vinyl chloride	IIA	472	T1	1,3 Butadiene	IIB	430	T2
Dichlorobenzene	IIA	648	T1	Dioxane	IIB	245	T3
Dichloroethylene 1,1	IIA	570	T1	Diethyl ether	IIB	160	T4
Dichloroethylene 1,2	IIA	441	T2	Ethyl vinyl ether	IIB	200	T3
Diethylamine	IIA	312	T2	Methyl vinyl ether	IIB	350	T2
Dimethylamine	IIA	400	T2	Acrylate ethyl	IIB	350	T2
Dimethylaniline	IIA	371	T2	Ethylene	IIB	425	T2
Dimethylbutane 2,3	IIA	405	T2	LPG	IIB	365	T2
Dimethylpentane 2,3	IIA	330	T2	Sulphurated Hydrogen	IIB	260	T3
Heptane	IIA	215	T3	Methylacrylate	IIB	415	T2
Hexane	IIA	233	T3	Carbon monoxide	IIB	605	T1
Heptane	IIA	515	T1	Ethylene oxide	IIB	435	T2
Ethylacetoacetate	IIA	350	T2	Propylene oxide	IIB	430	T2
Ethylamine	IIA	385	T2	Acetylene	IIC	305	T2
Ethylmercaptane	IIA	295	T3	Hydrogen	IIC	500	T1
Butyl formate	IIA	320	T2	Carbon disulfide	IIC	95	T6

DUST- Main inflammable substances					
	Substance	Medium largeness particles (µm)	LEL (g/m3)	Cloud ignition temperature Tci (°C)	Layer 5mm thick ignition temperature TI (°C)
Metals, alloys	Aluminium	10	60	560	430
	Bronze	18	750	390	260
	Iron	12	500	580	>450
	Graphite	7	30	600	680
	Lamp-black (carbon black)	13	15	620	435
	Sulphur	20	30	280	260
Wood, products of wood, fibres	Paper		100	620	370
	Cellulose (93% sweet wood, 6% hard wood)	14	15	420	335
	wood flour	60		470	305
	Wood (50% pear tree and 50% kernel)	35	100	500	340
	Wood (beech)	61		490	310
	Wood (pear tree)	27	100	500	320
	Sawdust of wood	65		470	290
	Cork	42	30	470	300
	Cacao	3	125	460-540	245
	Coffee	10	25	360	450
Agricultural products	Cereals (mixed powders)	37	125	510	300
	Wheat flour	56-125	60	480	>450
	Soy flour	20	200	620	280
	Gelatine	65	60	560	>450
	Wheat		100	470	220
	Dry milk	165	60	460	330
	Milk sugar	22	60-125	450	>450
	Rye			415-470	325
	Buttermilk	400		450	420
	Tobacco		60	485	290
	Black tea	76	125	510	300
Sugar	32	30	360	>450	
Powdered sugar	17	60	350	>450	



3. General informations

3.1 Range of motors

Ex Elprom motors are manufactured in compliance with all the European standards concerning equipment and protective systems for potentially explosive atmosphere in compliance with the European Directive ATEX 94/9/CE (better known as ATEX).

Here below in the table we show you the range of motors for each type of protection.

In the following pages we will speak about testing and certificates, main features of these motors and options that is possible to have depending always on the type of protection.

Range of motors									
Version	Type	Frame size	Pole N°	Output range (kW)	Type of Protection	Temperature class Surface temperature	ATEX Category	ATEX Zone	
GAS	Increased safety	3-ph 1 speed	56-160	2	0,09 – 18,5	Ex eb	T3 Ta –40°C +55°C T4 Ta –40°C +40°C	2G	1-2
			56-160	4	0,06 – 15				
			63-160	6	0,09 – 11				
			71-160	8	0,09 – 7,5				
		3-ph 2 speeds	71-160	4-2	0,22/0,33 – 12,5/18,5				
			71-160	8-4	0,11/0,18 – 4,1/6,4				
	1-ph 1 speed (2)	56-112	2	0,09 – 4					
		56-112	4	0,06 – 3					
	Non sparking	3-ph 1 speed	56-160	2	0,09 – 18,5	Ex nAc	T3 Ta –20°C +40°C T4 Ta –20°C +40°C	3G	2
			56-160	4	0,06 – 15				
			63-160	6	0,09 – 11				
			71-160	8	0,09 – 7,5				
		3-ph 2 speeds	71-160	4-2	0,22/0,33 – 12,5/18,5				
			71-160	8-4	0,11/0,18 – 4,1/6,4				
1-ph 1 speed (2)	56-112	2	0,09 – 4						
	56-112	4	0,06 – 3						
DUST	Dust ignition protection (conductive Dust) (1)	3-ph 1 speed	56-160	2	0,09 – 18,5	Ex tb IIIC	T125°C Ta –40°C +55°C	2D	21-22
			56-160	4	0,06 – 15				
			63-160	6	0,09 – 11				
			71-160	8	0,09 – 7,5				
		3-ph 2 speeds	71-160	4-2	0,22/0,33 – 12,5/18,5				
			71-160	8-4	0,11/0,18 – 4,1/6,4				
	1-ph 1 speed (2)	56-112	2	0,09 – 4					
		56-112	4	0,06 – 3					
	Dust ignition protection (non-conductive Dust) (1)	3-ph 1 speed	56-160	2	0,09 – 18,5	Ex tc IIIB	T125°C Ta –20°C +40°C	3D	22
			56-160	4	0,06 – 15				
			63-160	6	0,09 – 11				
			71-160	8	0,09 – 7,5				
		3-ph 2 speeds	71-160	4-2	0,22/0,33 – 12,5/18,5				
			71-160	8-4	0,11/0,18 – 4,1/6,4				
1-ph 1 speed (2)	56-112	2	0,09 – 4						
	56-112	4	0,06 – 3						
(1)	These motors, if provided of Thermal Protection (normally PTC) inside the windings, can be driven by frequency converters.								
(2)	The capacitor of the single phase motors is put inside a special Ex d cylindrical enclosure fitted on the motor itself. Otherwise it must be placed in a safe area.								



3.2 Testing and certificates

Motors for hazardous areas have to be officially approved by a recognized test organization, authorized to issue test certificates, to ensure compliance with standards for this type of equipment.

Motors are defined and classified according to the categories and protection type which are defined in the corresponding standards.

Depending on the nature of the atmosphere, it is the responsibility of the user to determine which group and which maximum surface temperature should be specified for the motor installation.

The Ex motors built by Elprom are manufactured in compliance with all the European standards concerning equipments and protective systems for explosive atmosphere as requested by the European Directive 94/9/CE (better known as ATEX Directive).

The motors have been tested by a Notified Laboratory which released:

- EC Type Certificate
- Product Quality assurance Notification

It means that all the Ex motors are manufactured in compliance with the technical drawings and documents approved by the Notified Body after testing the motors (performing type test as written in the EN standards) and the production of such motors follows all the procedures requested by the Directive.

Every year the Production of Ex motors is valued by a Notified body to verify that all the procedures are constantly respected.

Each motor or batch of motors will be despatched together with the following documents:

- EC Declaration of Conformity
- Installation manual and safety instructions where are written all the indication regarding the installations of the motors and the important instructions regarding the type/s of protection of the motors.

As explained before Elprom produces different Ex motors that can be installed in different Ex areas.

3.3 Main features

ELPROM Ex electric motors are built and tested in comply with all the EN/IEC standards and also comply with the main European Directives. First of all the directive 94/9/EC (ATEX as already explained), 89/336/EC (EMC Electro Magnetic Compatibility), 98/37/EC (Machinery Directive), 2002/95/EC (RoHS).

All the motors are asynchronous with squirrel cage rotor, wound stator, closed and externally ventilated in comply with EN 60034-6 (IC 411).

Supply voltage 230/400 V \pm 5% Δ /Y (56 - 112), 400/690 V \pm 5% Δ /Y (132 - 160) and frequency 50 Hz \pm 2% (EN 60034-1).

The power ratings and the dimensions of the motors comply with EN 50347 and IEC 60072-1, the mounting arrangements B3, B5, B14 comply with EN 60034-7.

All the geometrical dimensions are unified following the tables UNEL 13113-71; 13117-71; 13118- 7; IEC 60072-1.

The IP degrees of protection of the motors comply with EN 60034-5. It depends on the type of protection as follow:

Ex e:	IP55 (they have to be at least IP54 as requested by the standard EN 60079-7)
Ex nA:	IP55 (they have to be at least IP54 as requested by the standard EN 60079-15)
Ex tc IIIB:	IP55 for non-conductive dust (the standard EN 60241-1 states that it have to be at least IP5X)
Ex tb IIIC:	IP65 (or IP66) for conductive dust (the standard EN 60241-1 states that it have to be at least IP6X)

Insulation class. All the motors have an insulation class F in compliance with EN 60034-1.

The bearings are high-quality single raw deep grooves ball bearings, preloaded by a wave spring.

Duty. The motors are normally built for S1 duty, otherwise S3 duty can be done on request after performing the heating tests.

Single-phase motors. Capacitor placed in a safe Ex d cylindrical box fitted to the motor.

Windings:

Made using enamelled copper wires are insulated by two layers (insulation class H). They are painted with another layer of varnish and after this placed in an oven so to dry it.

The maximum ambient temperature is 40 °C.

It is also possible to tropicalize the windings using special additional varnish with high hygroscopic characteristics so to be used in places with an humidity >60% (see options)

Rotors

Die-cast aluminium squirrel cage aluminium alloy slots.

The shafts of the motors and the keys-shaft comply IEC 60072-1. Special shaft are made on request (see options).

Frame (in compliance with IEC 60072-1)

Die-cast aluminium with high mechanical strength, with a good thermal conductivity and light weight. The feet can be mounted on the motor frame in 3 different positions, in the bottom or on right and left side.

Terminal box

The terminal box in case of motor B3, is normally on the top of the motor. As the feet can mounted also on the sides of the frame it is possible to have the terminal box on both the sides of the motor too.

Flanges and shields (in compliance with IEC 60072-1)

Die-cast aluminium, with dimensions as per standard IEC 60072-1, or with special shapes on request (see options).

Ventilation (in compliance with EN 60034-6)

Self-ventilated motors IC 411. Depending on the type of protection the fan can be in plastic (Ex e, Ex nA, Ex tc) or in aluminium (Ex tb).

Fan cover

Zinc-plated steel sheet.

Noise (in compliance with EN 60034-9)



3.4 Main Options

Axially locked shaft (IEC63 ... IEC160)

Motors with a locked bearing on the front shield using an elastic metal ring. This solution is necessary in case of alternative axial stress (ie. Bevel gear pinion with alternative load or motion, frequent start-up under load or with high inertia) so to create axial movement of the shaft and bumps on the bearings.

Low temperatures motors (-40 °C) (IEC56 ... IEC160)

They have to be fitted with special bearing, metallic fan, metallic cable gland and plugs or made of special plastic materials. In these cases, if there is a risk of condensation, it is better to fit the motors with "anti-condensation heaters" or drain holes.

Anticondensation Heaters (IEC80 ... IEC160)

For motors installed in cold and wet places, with significant temperature ranges, moisture condensation can be dangerous for the resistance of the winding insulation. Upon request, you can apply appropriate heaters directly on the heads of winding.

The terminals are connected to a terminal board inside the connection box of the motor.

The heaters are available at 110V and 220 V, with a tolerance of +/- 10%

Condensation drain holes

These are motors with proper drain holes, for the discharge of condensed water that forms in specific climatic conditions.

If necessary motors with these characteristics is appropriate to indicate not only the mounting type but also the position of the motor during the final use, in order to determine the proper location of the drain holes.

The motors are delivered with the holes sealed by a plug.

Tropicalization of windings

If the motors are installed outdoors or in high humidity areas, the windings may be tropicalized with a special varnish that has high hygroscopic characteristics in order to protect the insulation materials by the condensation. This protection avoid the reduction of the insulation properties of the windings.

Inverter duty motors

Only the motors Ex tb, Ex tc (Zones 21 and 22) can be driver by a converter. They must be fitted with thermal protections inside the windings.

Special voltages and frequencies

The standard three phase motors are produced at the following nominal voltages and frequencies:

230 / 400 V, 50 Hz - up to 4 kW

400 / 690 V, 50 Hz - more than 4 kW

The motors can run at a different nominal voltage with a tolerance of +/- 5%

On customer request, we can produce motors with special voltage and frequency.

Special shafts

On customer request, it is possible to supply motors with special shaft as customer drawing. Send a drawing to our Technical Department for a feasibility study. It is possible to supply motors with shaft material different from the standard (C40), using Stainless Steel or others, with standard dimensions or special as customer drawing.

Special flanges

In some applications it is necessary to use special flanges on customer design to optimize the assembling or reduce the costs avoiding the use of adaptors. It is possible to send to our Technical Department a request with drawings and material specifications. Shortly will be made a cost evaluation of the parts and the tools.

Mating tolerances under "accuracy" rating to UNEL 13501-69 (DIN 42955) (special IM B5, IM B14, IM B5)

For application that need particularly small tolerances between shaft and shields due to particular couplings (ie.: gears-motors).

Rain fan cover

For outdoor applications, vertical mounting, DE shaft down (V5, V1, V18) it is suggested to assemble a special cowl with a rain cover. It is available for all the frame sizes.

Thermistors (PTC Positive Temperature Coefficient)

They must be used in case of Ex tb motors driven by inverters.

They are fitted inside the windings in number of 3 with a series connection to be connected to an appropriate tripping device that cut off the motors supply in case the winding reach the thermal probe limit temperature.

On request will be available protectors with different temperature setting in respect of the maximum Temperature class or surface temperature of the motor.

Thermal cut-off (bimetallic probes)

Motors with 1 or 2 thermal protectors with normally closed contact in series connection into the winding.

Nominal current 1,6 A, nominal voltage 250 V c.a. The contact opens when the winding temperature reaches the setting temperature.

The series of contact shall be connected to an appropriate tripping device that cut off the motors supply in case the winding reach the thermal probe limit temperature.

On request will be available protectors with different temperature setting in respect of the maximum Temperature class or surface temperature of the motor.

Single-phase motor with balanced winding - BIPHASE

They have normally a starting torque higher that the standard 1-phase and can start easily without using a start capacitor.

Painting (against corrosion)

The Elprom motors have diecasted aluminium components and sandblasted. If it is not requested the motors are supplied unpainted.

On specific request and for batches of not less than 30 pcs., it is possible to have painted motors with epoxy paint, with the customer requested colour. Other paints with anti salt characteristics are available on request; contact our Technical Department.



3.5 Motors identification

Motors identification				J2	063	A	4	H	230	5	F	Z	3
Motor type													
K2	Single-phase category 2	K3	Single-phase category 3										
J2	Three-phase category 2	J3	Three-phase category 3										
Motor shaft height													
56, 63, 71, 80, 90, 100, 112, 132, 160													
Stator dimensions													
A, B	56, 63, 71, 80												
S, L	90												
K, M	100												
M	112												
S, K, M, L	132												
S, M, L	160												
Poles													
2, 4	Single-phase motors												
2, 4, 6, 8	Three-phase motors 1 speed												
3, 5	Three-phase motors 2 speeds 2/4 and 4/8 poles												
Mounting arrangements													
H	B3	W	B3/B14										
B	B3 right box	X	B3/B5										
S	B3 left box	J	B3/B14 left box										
F	B5	M	B3/B14 right box										
G	V1 (B5 + rain cover)	R	B3/B5 left box										
Q	B14	T	B3/B5 right box										
Supply voltage													
Three-phase 1 speed													
230	For 230/400V Motors												
400	For 400/690V Motors												
Three-phase 2 speeds													
230 oder 400	-												
Single-phase													
230	-												
Frequency													
5	50Hz												
6	60Hz												
Protection (IP and Ex)													
F	IP55 – Increased safety ‘Ex e’												
G	IP65 - Protection Ex tb IIIC (Conductive dust)												
H	Increased safety ‘Ex e’ IP65 - Protection Ex tb IIIC (Conductive dust)												
N	Protection ‘Ex nA’ IP55 - Protection Ex tc IIIB (Non Conductive dust)												
Painting													
Z	Not painted	M	BRIGHT BLACK RAL9005										
B	BLUE RAL5010	N	OPAQUE BLACK										
E	BLUE RAL5014	V	GREEN 5018										
K	BLUE RAL5015	W	WHITE RAL9001										
G	GREY RAL7031												
Thermal protectors													
-	Without thermal protectors												
3	Thermal protector (PTO) –Temperature Class T3												
4	Thermal protector (PTO) – Temperature class T4												
P	Thermistor PTC – Temperature Class T3												
U	Thermistor PTC – Temperature Class T4												



4. Terminal box, cable entries and connections

As the feet are can be mounted on the frame (motor size 63 – 160) it is possible to fix them in 3 different positions so to have the possibility to have the terminal box on the top or on the right and left sides of the motor (see picture 1)
 At the same time the terminal box can be mounted on the motor so to have the cable entries where it is necessary. So the cable entries can be in the four different positions (see picture 2).

Position of terminal box and cable entries

Picture 1

Picture 2

Motor size	Cable glands	
	Main	Aux
56	M20	M16
63	M20	M16
71	M20	M16
80	M20	M20
90	M20	M20
100	M20	M20
112	M20	M20
132	M32	M20
160	M32	M20

Motors 'Ex e' and 'Ex nA'

The increased safety motors and no sparking motors are built with a special terminal board and the cable glands shall be certified in compliance with EN 60079-7 for the motor 'Ex e' and with EN 60079-15 for the motors 'Ex nA'.

In the picture you can see the special terminal board (complying with EN 60079-7) used for these motors and the type of connection requested so to satisfy both the standards EN 60079-7 and EN 60079-15. In case of motor fitted with thermal protection heaters etc. the wires of these devices will be connected when possible to the auxiliary pins of a 8 pins terminal board. If it is not possible they must be connected to the cable welding the wires of the device to the cable wires and insulating them using a thermic sheath.

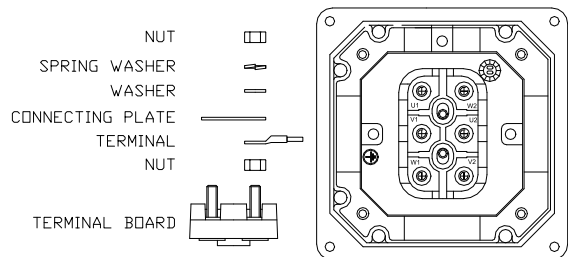

Motors 'Ex Tb, Ex tc'

For these type of motors there is no need of a special terminal board and the cable glands shall be certified in compliance with EN 61241-0 and 61241-1.

Motors without terminal box complete of cable

To reduce the total height of the motor, it is possible to have the motor without terminal box and complete of supply cable. The cable outlet can be on the top or on the sides.

Wiring diagrams

<p style="text-align: center;">3-ph 1 speed</p> <div style="display: flex; justify-content: space-around;"> <div style="text-align: center;"> <p>Delta connection (lower voltage)</p> </div> <div style="text-align: center;"> <p>Star connection (Higher voltage)</p> </div> </div>	<p style="text-align: center;">3-ph 1 speed (9 wires)</p> <div style="display: flex; justify-content: space-around;"> <div style="text-align: center;"> <p>lower voltage</p> </div> <div style="text-align: center;"> <p>Higher voltage</p> </div> </div>
<p style="text-align: center;">3-ph - 2 speeds - 1 winding Dahlander</p> <div style="display: flex; justify-content: space-around;"> <div style="text-align: center;"> <p>Low speed</p> </div> <div style="text-align: center;"> <p>High speed</p> </div> </div>	<p style="text-align: center;">3-ph - 2 speeds - 2 separate windings</p> <div style="display: flex; justify-content: space-around;"> <div style="text-align: center;"> <p>Low speed</p> </div> <div style="text-align: center;"> <p>High speed</p> </div> </div>
<p style="text-align: center;">1-ph - run capacitor (4 wires)</p> <div style="display: flex; justify-content: space-around;"> <div style="text-align: center;"> <p>Clockwise rotation (SHAFT SIDE VIEW)</p> </div> <div style="text-align: center;"> <p>Counter clockwise rotation (SHAFT SIDE VIEW)</p> </div> </div>	<p style="text-align: center;">1-ph - run capacitor (3 wires)</p> <div style="display: flex; justify-content: space-around;"> <div style="text-align: center;"> <p>Clockwise rotation (SHAFT SIDE VIEW)</p> </div> <div style="text-align: center;"> <p>Counter clockwise rotation (SHAFT SIDE VIEW)</p> </div> </div>

5. Mechanical Characteristics

Mounting arrangements					
Foot mounted					
IM 1001 (IM B3)	IM 1051 (IM B6)	IM 1061 (IM B7)	IM 1071 (IM B8)	M 1011 (IM V5)	IM 1031 (IM V6)
Flange mounted					
IM 3001 (IM B5)	IM 3011 (IM V1)	IM 3031 (IM V3)	IM 3601 (IM B14)	IM 3611 (IM V18)	IM 3631 (IM V19)
Foot-flange mounted					
IM 2001 (IM B35)	IM 2011 (IM V15)	IM 2031 (IM V36)	IM 2101 (IM B34)	IM 2111 (IM V58)	IM 2131 (IM V69)

Main components		
component	Material	Note
Frame	Aluminium	Removable feet (aluminium)
End- shields	Aluminium	
Flange B5	Aluminium	
Flange B14	Aluminium	
Terminal box	Aluminium	
Shaft	Steel C40	
Rotor	Magnetic lamination die-cast aluminium	
Stator	Magnetic lamination	
Windings	enamelled copper wires (two layers)	
V-Ring	NBR rubber	Special material: VITON
Bearings	Deep groove ball bearings	See Below
Fan	Plastic (Ex e, Ex nA), Aluminium or antistatic plastic (Ex tD A21)	

Bearings and seals					
Motor size	Bearings		Seals		Non-drive end
	Drive end	Non-drive end	Drive end	Non-drive end	
56	6201-ZZ	6201-ZZ	v-Ring Ø12	v-Ring Ø12	
63	6202-ZZ	6202-ZZ	v-Ring Ø14	v-Ring Ø14	
71	6202-ZZ	6202-ZZ	v-Ring Ø14	v-Ring Ø14	
80	6204-ZZ	6204-ZZ	v-Ring Ø20	v-Ring Ø20	
90	6205-ZZ	6205-ZZ	v-Ring Ø25	v-Ring Ø25	
100	6206-ZZ	6206-ZZ	v-Ring Ø30	v-Ring Ø30	
112	6306-ZZ	6306-ZZ	v-Ring Ø30	v-Ring Ø30	
132	6308-ZZ	6308-ZZ	v-Ring Ø40	v-Ring Ø40	
160	6309-ZZ	6309-ZZ	v-Ring Ø45	v-Ring Ø30	

The motors are normally fitted with permanently greased bearings of type ZZ, lubricated with a special grease G-15 and have a service max temperature of 150°C.

The bearing life time for aluminium motors is approximately (depending on application and load conditions):

- 2 and 2/4 pole motors, 10 000 - 20 000 duty hours
- 4 to 8 pole motors, 20 000 - 40 000 duty hours

Both on drive end and non-drive end are mounted V-ring seals in order to have the IP66 protection.

IP protection	Motors Ex e:	Motors Ex nA:	Motors Ex tc IIIB:	Motors Ex tb IIIC:
	IP55 (should be at least IP54 in compliance with EN 60079-7)	IP55 (should be at least IP54 in compliance with EN 60079-15)	IP55 (should at least IP6X in compliance with EN 61241-1 - conductive dust)	IP65 (should at least IP6X in compliance with EN 61241-1 – non conductive dust)

5.1 Radial and axial forces on the shaft end

5.1.1 Permissible radial load

Here we show the permissible radial load (F_R) that can be applied to three different positions (X_0 , $L/2$ and L where L is the length of the shaft axis) on the shaft-end, supposing motors running at 50Hz and bearings life time at least 20,000 hours for 2 poles motors and 40,000 hours for 4-6-8 poles. For service on 60Hz reduce values by 10%. Take the higher speed as reference for double pole motors.

This the formula to calculate F_R in a point of the shaft with generic position X : $F_R = F_{X0} - (F_{X0} - F_L)X/L$

Permissible radial load													
Motor size	Shaft length L (mm)	3000 rpm			1500 rpm			1000 rpm			750 rpm		
		X_0	L/2	L	X_0	L/2	L	X_0	L/2	L	X_0	L/2	L
56	20	350	325	300	350	325	300	-	-	-	-	-	-
63	23	390	365	340	390	365	340	450	420	390	-	-	-
71	30	490	450	410	490	450	410	560	515	470	610	565	520
80	40	650	590	530	650	590	530	750	680	610	820	745	670
90S	50	720	645	570	720	645	570	820	735	650	910	815	720
90L	50	720	650	580	720	650	580	830	750	670	920	830	740
100	60	1020	920	820	1020	920	820	1160	1045	930	1290	1165	1040
112	60	1410	1280	1150	1410	1280	1150	1610	1455	1300	1780	1610	1440
132	80	1520	1370	1220	1520	1370	1220	1540	1465	1390	1910	1720	1530
160	110	2750	2455	2160	2750	2455	2160	2750	2600	2450	3430	3055	2680

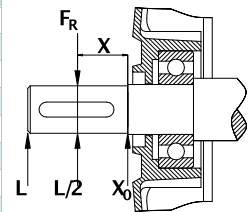

For Belt drive applications the maximum radial load F_R is given by:

$F_R = \text{maximum radial load [N]} = (P + F)$ where:

- P = pulley weight [N]
- F = belt tension [N] = $(2 \cdot K \cdot M)/D$ where:
 - K = belt tension factor ($K = 3$ for normal flat belt without idler pulley; $K = 2,2$ for V-belt; $K = 2$ for normal flat belt with idler pulley)
 - D = pulley diameter [m]
 - M = torque [Nm] = $9550 \cdot P/n$ where:
 - P = output [kW]
 - n = speed in [1/min]

5.1.2 Permissible axial load (with additional radial load applied at the end of the shaft)

In the table below we show the additional axial load (F_A) allowable if the maximum radial load (F_R) is applied on L .
The lower is radial load, the bigger is allowable axial load.

Axial load calculations have been carried out in three different foot mounting operating conditions: horizontal (B3), vertical shaft-down (V5) and vertical shaft-up (V6), supposing the case of thrust T or pull P force.

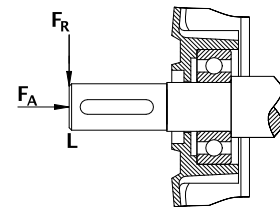

Permissible axial load (with maximum radial load applied on L)																								
Motor size	IM 1001 (IM B3)								M 1011 (IM V5)								IM 1031 (IM V6)							
	2 poles		4 poles		6 poles		8 poles		2 poles		4 poles		6 poles		8 poles		2 poles		4 poles		6 poles		8 poles	
	T	P	T	P	T	P	T	P	T	P	T	P	T	P	T	P	T	P	T	P	T	P	T	P
56	220	100	220	100	-	-	-	-	230	90	230	90	-	-	-	-	220	100	220	100	-	-	-	-
63	240	110	240	110	280	120	290	120	250	100	250	100	290	110	290	110	230	120	130	120	270	130	280	130
71	300	140	300	130	350	160	380	170	320	120	320	110	370	140	400	150	280	160	280	150	330	180	360	190
80	400	190	400	180	460	210	510	240	430	160	440	140	500	170	550	200	370	220	360	220	420	250	470	280
90S	430	200	430	210	500	230	550	260	460	170	470	170	540	190	590	220	400	230	390	250	460	270	510	300
90L	440	200	440	200	510	240	560	260	480	160	490	150	560	190	610	210	400	240	390	250	460	290	510	310
100	620	290	610	290	710	330	780	370	680	230	690	210	790	250	860	290	560	350	530	370	630	410	700	450
112	860	400	850	400	980	460	1080	500	950	320	960	290	1090	350	1190	390	780	480	740	510	870	570	970	610
132	920	430	920	430	1050	500	1170	550	1080	270	1130	220	1260	290	1380	340	760	590	710	640	840	710	960	760
160	1680	800	1670	800	1920	920	2120	1010	1940	540	1970	500	2220	620	2420	710	1420	1060	1370	1100	1620	1220	1730	1370



6. Electrical data

6.1 Motors for ATEX Zones 1, 21 (Increased safety 'Ex e', protection by enclosure 'tb' IIIC)

6.1.1 Three-phase motors, 1 speed

THREE PHASE MOTORS 1 SPEED 400V 50Hz 3000														
Type	Power [kW]	rpm	η	$\cos\phi$	I_N [A]	M_N [Nm]	I_A/I_N	M_A/M_N	M_{max}/M_N	T3 40°C	t_E (s) T3 55°C	T4 40°C	J_{rotor} [kgm ²]	Mass [kg]
J2 56A2	0,09	2750	64%	0,67	0,32	0,31	3,83	3	3,2	55	48	23	0,00010	2,2
J2 56B2	0,12	2680	50%	0,76	0,5	0,43	2,9	2	2,8	38	32	12	0,00012	2,5
J2 63A2	0,18	2825	56%	0,76	0,62	0,61	3,9	2,6	3,6	47	41	21	0,00017	3
J2 63B2	0,25	2750	60%	0,83	0,74	0,87	3,3	1,8	2,5	45	39	19	0,00022	3
J2 71A2	0,37	2850	71%	0,78	1	1,24	4,5	2,4	2,7	16	14	(*)	0,00035	5
J2 71B2	0,55	2840	70%	0,78	1,45	1,85	4,9	3,3	3,4	12	10	(*)	0,00045	5
J2 80A2	0,75	2870	73%	0,72	2	2,5	5,3	3	4,1	16	13	(*)	0,00068	8
J2 80B2	1,1	2810	72%	0,88	2,5	3,74	4	4	2,7	11	9	(*)	0,00088	10
J2 90S2	1,5	2870	72%	0,8	3,7	5	4,3	1,8	3	21	18	(*)	0,00118	12
J2 90L2	2,2	2860	76%	0,8	5,4	7,2	5,1	3,7	3,9	13	10	(*)	0,00180	14
J2 100L2	3	2900	78%	0,82	6,8	10	5,5	2	2,8	21	18	(*)	0,00279	18
J2 112M2	4	2915	78%	0,83	9,1	13,2	6,1	2,9	4,2	11	9	(*)	0,00544	26
J2 132K2	5,5	2910	80%	0,87	11,5	18,1	5,9	2,6	2,8	14	11	(*)	0,00993	43
J2 132S2	7,5	2900	79%	0,9	15,2	24,71	6,3	3	2,7	11	9	(*)	0,01316	45
J2 160K2	11	2900	83%	0,91	21	36,24	4,7	2,3	2,6	21	17	(*)	0,03275	95
J2 160M2	15	2930	80%	0,85	28	48,91	5	1,8	2,8	27	22	(*)	0,04519	100
J2 160L2	18,5	2910	84%	0,91	35	60,74	4,6	2	2,3	19	15	(*)	0,05393	110

THREE PHASE MOTORS 1 SPEED 400V 50Hz 1500														
Type	Power [kW]	rpm	η	$\cos\phi$	I_N [A]	M_N [Nm]	I_A/I_N	M_A/M_N	M_{max}/M_N	T3 40°C	t_E (s) T3 55°C	T4 40°C	J_{rotor} [kgm ²]	Mass [kg]
J2 56A4	0,06	1400	35%	0,6	0,41	0,41	2,5	2,3	2,5	46	40	17	0,00015	2,2
J2 56B4	0,09	1370	50%	0,6	0,46	0,63	2,8	2,3	2,5	32	28	11	0,00015	2,4
J2 63A4	0,12	1350	56%	0,75	0,44	0,88	2,5	1,8	2	38	34	16	0,00021	3
J2 63B4	0,18	1350	56%	0,67	0,66	1,3	2,5	2,1	2,2	45	39	17	0,00029	3
J2 71A4	0,25	1400	55%	0,81	0,84	1,7	3,8	2,4	2,8	33	28	10	0,00073	5,5
J2 71B4	0,37	1410	66%	0,68	1,2	2,52	3,9	2,5	2,9	26	22	7	0,00080	5,5
J2 80A4	0,55	1430	68%	0,71	1,75	3,75	4,3	2,7	3,2	27	22	7	0,00092	7
J2 80B4	0,75	1410	72%	0,75	2,1	5,1	3,9	2,3	2,4	27	25	8	0,00128	10
J2 90S4	1,1	1420	71%	0,7	3,3	7,5	3,7	2,8	3,2	27	22	7	0,00203	11
J2 90L4	1,5	1415	75%	0,78	3,8	10,16	4,2	2,2	3,1	18	15	(*)	0,00265	13
J2 100K4	2,2	1440	77%	0,77	5,8	14,5	4,9	2	2,3	17	14	(*)	0,00450	18
J2 100L4	3	1420	79%	0,81	6,8	20,3	4,4	1,9	2,7	17	14	(*)	0,00599	21
J2 112M4	4	1450	84%	0,76	9,1	26,4	4,8	2,2	3,5	14	12	(*)	0,01112	28
J2 132S4	5,5	1460	85%	0,81	11,5	36,3	5,1	2,1	2,8	22	19	(*)	0,02311	37
J2 132M4	7,5	1440	87%	0,82	15,5	50,2	5,5	2	2,4	12	10	(*)	0,02953	52
J2 160M4	11	1450	81%	0,86	22,8	72,48	5,3	2	2,4	16	13	(*)	0,06167	80
J2 160L4	15	1430	86%	0,84	30	100,22	4,7	1,8	2	19	16	(*)	0,08276	105

THREE PHASE MOTORS 1 SPEED 400V 50Hz 1000														
Type	Power [kW]	rpm	η	$\cos\phi$	I_N [A]	M_N [Nm]	I_A/I_N	M_A/M_N	M_{max}/M_N	T3 40°C	t_E (s) T3 55°C	T4 40°C	J_{rotor} [kgm ²]	Mass [kg]
J3 63B6	0,12	900	40%	0,60	0,8	1,3	1,8	2,4	2,6	27	23	7	0,00029	4,5
J2 71A6	0,18	900	62%	0,70	0,61	2	3	2	2,3	32	26	7	0,00060	5,7
J2 71B6	0,25	900	67%	0,71	0,77	2,7	3,2	2,4	2,4	39	33	10	0,00080	6,5
J2 80A6	0,37	940	63%	0,66	1,4	3,8	4	2,7	3,2	20	17	5	0,00220	8
J2 80B6	0,55	920	65%	0,65	2	5,7	2,7	2,3	2,4	25	21	6	0,00282	10
J2 90S6	0,75	930	71%	0,70	2,2	7,9	3,5	2,3	2,4	27	23	7	0,00265	12
J2 90L6	1,1	910	71%	0,76	2,95	11,5	3,5	1,6	2,1	22	19	5	0,00342	15
J2 100L6	1,5	950	76%	0,65	4,4	15,1	4,1	2,2	3,1	25	21	7	0,01033	20
J2 112M6	2,2	940	78%	0,75	5,6	22,3	3,6	1,5	2,2	16	14	(*)	0,01603	35
J2 132S6	3	920	81%	0,73	7,8	29,6	5,3	1,7	2,7	20	17	(*)	0,03159	40
J2 132K6	4	960	84%	0,74	9,2	40	5	2	2,9	18	15	(*)	0,03786	47
J2 132M6	5,5	950	85%	0,74	12,5	54,2	5	1,6	2,2	13	10	(*)	0,04541	52
J2 160M6	7,5	970	89%	0,76	16	74	5,7	2	3	11	9	(*)	0,09345	80
J2 160L6	11	960	89%	0,8	22,5	109	5,4	1,9	2,6	8	7	(*)	0,12728	100



THREE PHASE MOTORS 1 SPEED 400V 50Hz 750														
Type	Power [kW]	rpm	η	$\cos\phi$	I_N [A]	M_N [Nm]	I_A/I_N	M_A/M_N	M_{max}/M_N	T3 40°C	t_E (s) T3 55°C	T4 40°C	J_{rotor} [kgm ²]	Mass [kg]
J2 80A8	0,18	690	49%	0,6	0,95	2,5	2,8	2,7	3	34	28	6	0,00141	8,6
J2 80B8	0,25	700	55%	0,55	1,2	3,6	2,9	2,8	3,2	32	26	5	0,00251	10
J2 90S8	0,37	680	60%	0,67	1,3	5,2	3	1,6	2	44	37	11	0,00376	12
J2 90L8	0,55	690	65%	0,65	1,9	7,7	3	2,4	2,7	41	34	10	0,00551	14
J2 100K8	0,75	700	65%	0,65	2,6	10	3,4	2,3	2,5	27	22	5	0,00775	18
J2 100L8	1,1	700	63%	0,69	3,6	15,2	3,7	2,2	2,6	21	17	(*)	0,01033	20
J2 112M8	1,5	710	77%	0,72	3,9	20,2	3,7	1,3	2,2	24	20	(*)	0,01870	35
J2 132S8	2,2	710	75%	0,67	6,4	30	3,4	1,6	2,5	28	23	7	0,03223	45
J2 132L8	3	700	78%	0,79	7	41	4	1,6	2	29	25	9	0,04000	53
J2 160S8	4	710	82%	0,78	9	53,1	4,1	2	2,3	13	11	(*)	0,08000	65
J2 160M8	5,5	715	85%	0,76	12,7	73	4	2	2,4	12	10	(*)	0,09200	72
J2 160L8	7,5	720	86%	0,97	15,9	98,2	4,2	1,9	2,4	14	12	(*)	0,11200	89

(*) Bimetal thermal protector 120°C±5°C

IMPORTANT :

Inverter Duty:

even if the 3-ph motors with type of protection 'Ex e' can be equipped with a thermal protection they can't be used for inverter duty. To be driven by an inverter the motors must be tested with a precise type of inverter and certified for that type.

In case the motor is equipped with thermal protectors fitted inside the windings, the thermal sensors have to be connected to an appropriate tripping device that cut off the motors supply in case the winding reach the thermal probe limit temperature. In this case on the motor label it won't be necessary to write the tE time.

6.1.2 Three phase motors, double speed

THREE PHASE MOTORS DOUBLE SPEED 400V 50Hz 1500/3000											
Type	Power [kW]	Poles	rpm	I_N [A]	I_A/I_N	M_A/M_N	M_{max}/M_N	Thermal Protector T3 T4		J_{rotor} [kgm ²]	Mass [kg]
J2 71A3	0,22	4	1380	0,8	3,2	1,9	2,3	150°C	120°C	0,00050	6
	0,33	2	2760	1	3,8	1,8	2,3				
J2 71B3	0,4	4	1380	1,2	3,2	1,9	2,2	150°C	120°C	0,00080	6,5
	0,5	2	2800	1,25	4,2	1,8	2,2				
J2 80A3	0,45	4	1430	1,5	3,9	2	2,3	150°C	120°C	0,00140	8
	0,6	2	2880	1,9	4,1	2	2,3				
J2 80B3	0,6	4	1450	2,2	4	2	2,3	150°C	120°C	0,00170	10
	0,8	2	2890	2,6	4,3	2	2,3				
J2 90S3	0,8	4	1440	2,6	4,5	2,3	2,6	150°C	120°C	0,00330	12
	1,1	2	2890	3,4	5	2	2,5				
J2 90L3	1,1	4	1420	3,2	4,3	2,4	2,7	150°C	120°C	0,00400	15
	1,5	2	2880	4,8	4,9	2,3	2,4				
J2 90L3A	1,3	4	1430	3,6	4,5	2,6	2,7	150°C	120°C	0,00500	16
	1,7	2	2850	4,6	5	2,4	2,4				
J2 100M3	1,5	4	1430	4	6	2,4	2,6	150°C	120°C	0,00750	18
	2,2	2	2850	5,7	6	2,3	2,5				
J2 100L3	2,2	4	1440	5,7	6,2	2,5	2,6	150°C	120°C	0,00860	23
	3	2	2870	8,1	6	2,3	2,5				
J2 112M3	3,3	4	1450	7	6,2	2,5	2,6	150°C	120°C	0,01300	28
	4	2	2900	9,1	6	2,3	2,4				
J2 132S3	4,5	4	1430	10	6,3	2,6	2,9	150°C	120°C	0,01600	53
	5,5	2	2900	11,5	6	2,4	2,8				
J2 132M3	6,5	4	145	13,2	6,2	2,6	2,9	150°C	120°C	0,02300	55
	8,1	2	2890	16	6	2,5	2,7				
J2 132L3	8	4	1450	18	5,8	2,6	2,9	150°C	120°C	0,03300	58
	9,5	2	2930	22	5,5	2,5	2,7				
J2 160S3	9,3	4	1460	20	5,6	2,4	2,8	150°C	120°C	0,06200	85
	11	2	2930	25	5,3	2,3	2,6				
J2 160M3	12	4	1460	26	6,2	2,4	2,8	150°C	120°C	0,06500	91
	14	2	2930	32	6	2,3	2,6				
J2 160L3	12,5	4	1460	27	6,3	2,3	2,8	150°C	120°C	0,07400	105
	18,5	2	2930	35	6	2,1	2,4				



THREE PHASE MOTORS DOUBLE SPEED 400V 50Hz 750/1500											
Type	Power [kW]	Poles	rpm	I _N [A]	I _A /I _N	M _A /M _N	M _{max} /M _N	Thermal Protector T3 T4		J _{rotor} [kgm ²]	Mass [kg]
J2 71A5	0,11	8	670	0,8	2,4	1,4	2	150°C	120°C	0,00180	6,3
	0,18	4	1370	0,9	3,4	1,1	1,8				
J2 71B5	0,15	8	670	1,1	2,4	1,4	2	150°C	120°C	0,00200	6,5
	0,3	4	1370	1,2	3,5	1,1	1,8				
J2 80A5	0,22	8	700	1,3	2,4	1,6	2	150°C	120°C	0,00230	8,7
	0,45	4	1420	1,4	3,5	1,5	1,8				
J2 80B5	0,37	8	700	2	2,6	1,6	2,2	150°C	120°C	0,00300	8,2
	0,55	4	1410	1,4	3,6	1,5	1,8				
J2 90S5	0,6	8	700	2,8	3,2	1,7	2,2	150°C	120°C	0,00430	12,5
	1,1	4	1420	2,5	4	2	1,8				
J2 100M5	0,7	8	700	3,5	5	2,5	2,8	150°C	120°C	0,00770	18
	1,1	4	1430	3	5,2	2,2	2,4				
J2 100L5	1,1	8	710	5	5,2	2,4	2,8	150°C	120°C	0,00860	20
	1,8	4	1430	4,6	5,5	2,3	2,4				
J2 112M5	1,4	8	710	5,3	5,2	2,5	2,8	150°C	120°C	0,01200	35
	2,6	4	1430	5,3	5,5	2,3	2,6				
J2 132S5	2,4	8	720	4,8	5,2	2,5	2,8	150°C	120°C	0,03000	45
	4,5	4	1440	8	5,2	2,3	2,4				
J2 132M5	2,6	8	720	8	5,3	2,5	2,8	150°C	120°C	0,04000	50
	4,1	4	1430	10,5	5,4	2,3	2,4				
J2 132L5	3	8	720	8,7	5,3	2,4	2,8	150°C	120°C	0,05500	54
	5,5	4	1440	12	5,4	2,2	2,5				
J2 160M5	4,1	8	720	12,7	5,2	2,4	2,8	150°C	120°C	0,11200	85
	6,4	4	1440	13,8	5,3	2,2	2,5				

The double speed motors are always equipped with thermal protectors fitted inside the windings; the thermal sensors have to be connected to an appropriate tripping device that cut off the motors supply in case the winding reach the thermal probe limit temperature. In this case on the motor label it won't be necessary to write the tE time.

6.1.3 Single-phase motors, 1 speed

SINGLE-PHASE MOTORS 1 SPEED PERMANENT CAPACITOR 230 50Hz 3000														
Type	Power [kW]	rpm	η	cosφ	I _N [A]	M _N [Nm]	I _A /I _N	M _A /M _N	M _{max} /M _N	C[μF]	Thermal protector T3 T4		J _{rotors} [kgm ²]	Mass [kg]
K2 56A2	0,09	2740	65%	0,86	0,7	0,31	2,3	0,6	1,5	3	150°C	120°C	0,00012	2
K256B2	0,12	2760	76%	0,86	0,8	0,42	2,6	0,6	1,5	4	150°C	120°C	0,00015	2,6
K2 63A2	0,18	2780	76%	0,86	1,2	0,62	2,9	0,6	1,4	4	150°C	120°C	0,00030	4,3
K2 63B2	0,25	2780	60%	0,9	2	0,86	2,9	0,65	1,5	6	150°C	120°C	0,00035	4,5
K2 71A2	0,37	2790	50%	0,9	3,6	1,27	3,1	0,7	1,4	10	150°C	120°C	0,00046	6
K2 71B2	0,55	2800	58%	0,9	4,6	1,88	3,1	0,63	1,4	16	150°C	120°C	0,00056	6,5
K2 80A2	0,75	2830	59%	0,92	6	2,53	3,2	0,7	1,4	25	150°C	120°C	0,00097	8
K2 80B2	1,1	2800	64%	0,94	8	3,75	3,3	0,7	1,6	30	150°C	120°C	0,01000	10
K2 90S2	1,5	2850	71%	0,9	10,2	5,03	3,3	0,6	1,8	40	150°C	120°C	0,00150	12
K2 90L2	1,5	2850	69%	0,9	10,5	5,03	3,4	0,55	1,5	40	150°C	120°C	0,00190	14
K2 100M2	2,2	2850	71%	0,9	15	7,38	3,5	0,55	1,7	60	150°C	120°C	0,00370	23
K2 100L2	3	2850	66%	0,9	22	10,06	3,6	0,6	1,8	80	150°C	120°C	0,00530	25

SINGLE-PHASE MOTORS 1 SPEED PERMANENT CAPACITOR 230 50Hz 1500														
Type	Power [kW]	rpm	η	cosφ	I _N [A]	M _N [Nm]	I _A /I _N	M _A /M _N	M _{max} /M _N	C[μF]	Thermal protector T3 T4		J _{rotors} [kgm ²]	Mass [kg]
K2 56A4	0,06	1340	53%	0,94	0,9	0,43	2,6	0,6	1,5	2	150°C	120°C	0,00018	2,6
K2 56B4	0,09	1350	55%	0,95	1	0,64	2,6	0,6	1,5	4	150°C	120°C	0,00020	2,8
K2 63A4	0,12	1360	58%	0,93	1,3	0,84	2,8	0,63	1,4	4	150°C	120°C	0,00040	3,4
K2 63B4	0,18	1360	59%	0,95	1,4	1,26	2,8	0,62	1,5	6,3	150°C	120°C	0,00045	3,6
K2 71A4	0,25	1400	59%	0,94	2,5	1,71	3	0,55	1,4	10	150°C	120°C	0,00080	6,5
K2 71B4	0,37	1400	59%	0,93	3,6	2,53	3,2	0,56	1,4	10	150°C	120°C	0,00090	7,2
K2 80A4	0,55	1410	60%	0,94	4,8	3,73	3,2	0,45	1,4	16	150°C	120°C	0,00096	8
K2 80B4	0,75	1410	63%	0,96	5,4	5,08	3,3	0,5	1,6	20	150°C	120°C	0,00120	10
K2 90S4	1,1	1400	65%	0,95	8	7,51	3,4	0,45	1,5	30	150°C	120°C	0,00260	13
K2 90L4	1,5	1410	67%	0,93	10,5	10,16	3,5	0,44	1,8	40	150°C	120°C	0,00320	15
K2 100M4	2,2	1415	70%	0,96	15,6	14,85	3,8	0,55	1,6	45	150°C	120°C	0,00590	22

Capacitor: is fitted inside a special 'Ex d' cylindrical box and mounted on the motor.

The single phase motors are always equipped with thermal protectors fitted inside the windings, the thermal sensors have to be connected to an appropriate tripping device that cut off the motors supply in case the winding reach the thermal probe limit temperature. In this case on the motor label it won't be necessary to write the tE time.



6.2 Motors for ATEX Zones 2, 22 (Non-sparking 'Ex nA', protection by enclosure 'tc' IIIB)

6.2.1 Three-phase motors, 1 speed

THREE PHASE MOTORS 1 SPEED 400V 50Hz 3000											
Type	Power [kW]	rpm	η	$\cos\phi$	I_N [A]	M_N [Nm]	I_A/I_N	M_A/M_N	M_{max}/M_N	J_{rotor} [kgm ²]	Mass [kg]
J3 56A2	0,09	2750	64%	0,67	0,32	0,31	3,83	3	3,2	0,00010	2,2
J3 56B2	0,12	2680	50%	0,76	0,5	0,43	2,9	2	2,8	0,00012	2,5
J3 63A2	0,18	2825	56%	0,76	0,62	0,61	3,9	2,6	3,6	0,00017	3
J3 63B2	0,25	2750	60%	0,83	0,74	0,87	3,3	1,8	2,5	0,00022	3
J3 71A2	0,37	2850	71%	0,78	1	1,24	4,5	2,4	2,7	0,00035	5
J3 71B2	0,55	2840	70%	0,78	1,45	1,85	4,9	3,3	3,4	0,00045	5
J3 80A2	0,75	2870	73%	0,72	2	2,5	5,3	3	4,1	0,00068	8
J3 80B2	1,1	2810	72%	0,88	2,5	3,74	4	4	2,7	0,00088	10
J3 90S2	1,5	2870	72%	0,8	3,7	5	4,3	1,8	3	0,00118	12
J3 90L2	2,2	2860	76%	0,8	5,4	7,2	5,1	3,7	3,9	0,00180	14
J3 100L2	3	2900	78%	0,82	6,8	10	5,5	2	2,8	0,00279	18
J3 112M2	4	2915	78%	0,83	9,1	13,2	6,1	2,9	4,2	0,00544	26
J3 132K2	5,5	2910	80%	0,87	11,5	18,1	5,9	2,6	2,8	0,00993	43
J3 132S2	7,5	2900	79%	0,9	15,2	24,71	6,3	3	2,7	0,01316	45
J3 132L2	9,3	2930	80%	0,88	20	30,3	5,8	2,4	2,7	0,01626	50
J3 160K2	11	2900	83%	0,91	21	36,24	4,7	2,3	2,6	0,03275	95
J3 160M2	15	2930	80%	0,85	28	48,91	5	1,8	2,8	0,04519	100
J3 160L2	18,5	2910	84%	0,91	35	60,74	4,6	2	2,3	0,05393	110

THREE PHASE MOTORS 1 SPEED 400V 50Hz 1500											
Type	Power [kW]	rpm	η	$\cos\phi$	I_N [A]	M_N [Nm]	I_A/I_N	M_A/M_N	M_{max}/M_N	J_{rotor} [kgm ²]	Mass [kg]
J3 56A4	0,06	1400	35%	0,6	0,41	0,41	2,5	2,3	2,5	0,00015	2,2
J3 56B4	0,09	1370	50%	0,6	0,46	0,63	2,8	2,3	2,5	0,00015	2,4
J3 63A4	0,12	1350	56%	0,75	0,44	0,88	2,5	1,8	2	0,00021	3
J3 63B4	0,18	1350	56%	0,67	0,66	1,3	2,5	2,1	2,2	0,00029	3
J3 71A4	0,25	1400	55%	0,81	0,84	1,7	3,8	2,4	2,8	0,00073	5,5
J3 71B4	0,37	1410	66%	0,68	1,2	2,52	3,9	2,5	2,9	0,00080	5,5
J3 80A4	0,55	1430	68%	0,71	1,75	3,75	4,3	2,7	3,2	0,00092	7
J3 80B4	0,75	1410	72%	0,75	2,1	5,1	3,9	2,3	2,4	0,00128	10
J3 90S4	1,1	1420	71%	0,7	3,3	7,5	3,7	2,8	3,2	0,00203	11
J3 90L4	1,5	1415	75%	0,78	3,8	10,16	4,2	2,2	3,1	0,00265	13
J3 100K4	2,2	1440	77%	0,77	5,8	14,5	4,9	2	2,3	0,00450	18
J3 100L4	3	1420	79%	0,81	6,8	20,3	4,4	1,9	2,7	0,00599	21
J3 112M4	4	1450	84%	0,76	9,1	26,4	4,8	2,2	3,5	0,01112	28
J3 132S4	5,5	1460	85%	0,81	11,5	36,3	5,1	2,1	2,8	0,02311	37
J3 132M4	7,5	1440	87%	0,82	15,5	50,2	5,5	2	2,4	0,02953	52
J3 132L4	9,3	1430	81%	0,83	21	62	5,5	3	3,2	0,03300	55
J3 160M4	11	1450	81%	0,86	22,8	72,48	5,3	2	2,4	0,06167	80
J3 160L4	15	1430	86%	0,84	30	100,22	4,7	1,8	2	0,08276	105

THREE PHASE MOTORS 1 SPEED 400V 50Hz 1000											
Type	Power [kW]	rpm	η	$\cos\phi$	I_N [A]	M_N [Nm]	I_A/I_N	M_A/M_N	M_{max}/M_N	J_{rotor} [kgm ²]	Mass [kg]
J3 63B6	0,12	900	40%	0,60	0,8	1,3	1,8	2,4	2,6	0,00029	4,5
J3 71A6	0,18	900	62%	0,70	0,61	2	3	2	2,3	0,00060	5,7
J3 71B6	0,25	900	67%	0,71	0,77	2,7	3,2	2,4	2,4	0,00080	6,5
J3 80A6	0,37	940	63%	0,66	1,4	3,8	4	2,7	3,2	0,00220	8
J3 80B6	0,55	920	65%	0,65	2	5,7	2,7	2,3	2,4	0,00282	10
J3 90S6	0,75	930	71%	0,70	2,2	7,9	3,5	2,3	2,4	0,00265	12
J3 90L6	1,1	910	71%	0,76	2,95	11,5	3,5	1,6	2,1	0,00342	15
J3 100L6	1,5	950	76%	0,65	4,4	15,1	4,1	2,2	3,1	0,01033	20
J3 112M6	2,2	940	78%	0,75	5,6	22,3	3,6	1,5	2,2	0,01603	35
J3 132S6	3	920	81%	0,73	7,8	29,6	5,3	1,7	2,7	0,03159	40
J3 132K6	4	960	84%	0,74	9,2	40	5	2	2,9	0,03786	47
J3 132M6	5,5	950	85%	0,74	12,5	54,2	5	1,6	2,2	0,04541	52
J3 160M6	7,5	970	89%	0,76	16	74	5,7	2	3	0,09345	80
J3 160L6	11	960	89%	0,8	22,5	109	5,4	1,9	2,6	0,12728	100



THREE PHASE MOTORS 1 SPEED 400V 50Hz 750											
Type	Power [kW]	rpm	η	$\cos\phi$	I_N [A]	M_N [Nm]	I_A/I_N	M_A/M_N	M_{max}/M_N	J_{rotor} [kgm ²]	Mass [kg]
J3 80A8	0,18	690	49%	0,6	0,95	2,5	2,8	2,7	3	0,00141	8,6
J3 80B8	0,25	700	55%	0,55	1,2	3,6	2,9	2,8	3,2	0,00251	10
J3 90S8	0,37	680	60%	0,67	1,3	5,2	3	1,6	2	0,00376	12
J3 90L8	0,55	690	65%	0,65	1,9	7,7	3	2,4	2,7	0,00551	14
J3 100K8	0,75	700	65%	0,65	2,6	10	3,4	2,3	2,5	0,00775	18
J3 100L8	1,1	700	63%	0,69	3,6	15,2	3,7	2,2	2,6	0,01033	20
J3 112M8	1,5	710	77%	0,72	3,9	20,2	3,7	1,3	2,2	0,01870	35
J3 132S8	2,2	710	75%	0,67	6,4	30	3,4	1,6	2,5	0,03223	45
J3 132L8	3	700	78%	0,79	7	41	4	1,6	2	0,04000	53
J3 160S8	4	710	82%	0,78	9	53,1	4,1	2	2,3	0,08000	65
J3 160M8	5,5	715	85%	0,76	12,7	73	4	2	2,4	0,09200	72
J3 160L8	7,5	720	86%	0,97	15,9	98,2	4,2	1,9	2,4	0,11200	89

IMPORTANT :

Inverter Duty:

even if the 3-ph motors with type of protection 'Ex nA' can be equipped with a thermal protection they **can't be used for inverter duty**. To be driven by an inverter the motors must be tested with a precise type of inverter and certified for that type.

6.2.2 Three phase motors, double speed

THREE PHASE MOTORS DOUBLE SPEED 400V 50Hz 1500/3000										
Type	Power [kW]	Poles	rpm	I_N [A]	I_A/I_N	M_A/M_N	M_{max}/M_N	J_{rotor} [kgm ²]	Mass [kg]	
J3 71A3	0,22	4	1380	0,8	3,2	1,9	2,3	0,00050	6	
	0,33	2	2760	1	3,8	1,8	2,3			
J3 71B3	0,4	4	1380	1,2	3,2	1,9	2,2	0,00080	6,5	
	0,5	2	2800	1,25	4,2	1,8	2,2			
J3 80A3	0,45	4	1430	1,5	3,9	2	2,3	0,00140	8	
	0,6	2	2880	1,9	4,1	2	2,3			
J3 80B3	0,6	4	1450	2,2	4	2	2,3	0,00170	10	
	0,8	2	2890	2,6	4,3	2	2,3			
J3 90S3	0,8	4	1440	2,6	4,5	2,3	2,6	0,00330	12	
	1,1	2	2890	3,4	5	2	2,5			
J3 90L3	1,1	4	1420	3,2	4,3	2,4	2,7	0,00400	15	
	1,5	2	2880	4,8	4,9	2,3	2,4			
J3 90L3A	1,3	4	1430	3,6	4,5	2,6	2,7	0,00500	16	
	1,7	2	2850	4,6	5	2,4	2,4			
J3 100M3	1,5	4	1430	4	6	2,4	2,6	0,00750	18	
	2,2	2	2850	5,7	6	2,3	2,5			
J3 100L3	2,2	4	1440	5,7	6,2	2,5	2,6	0,00860	23	
	3	2	2870	8,1	6	2,3	2,5			
J3 112M3	3,3	4	1450	7	6,2	2,5	2,6	0,01300	28	
	4	2	2900	9,1	6	2,3	2,4			
J3 132S3	4,5	4	1430	10	6,3	2,6	2,9	0,01600	53	
	5,5	2	2900	11,5	6	2,4	2,8			
J3 132M3	6,5	4	145	13,2	6,2	2,6	2,9	0,02300	55	
	8,1	2	2890	16	6	2,5	2,7			
J3 132L3	8	4	1450	18	5,8	2,6	2,9	0,03300	58	
	9,5	2	2930	22	5,5	2,5	2,7			
J3 160S3	9,3	4	1460	20	5,6	2,4	2,8	0,06200	85	
	11	2	2930	25	5,3	2,3	2,6			
J3 160M3	12	4	1460	26	6,2	2,4	2,8	0,06500	91	
	14	2	2930	32	6	2,3	2,6			
J3 160L3	12,5	4	1460	27	6,3	2,3	2,8	0,07400	105	
	18,5	2	2930	35	6	2,1	2,4			



THREE PHASE MOTORS DOUBLE SPEED 400V 50Hz 750/1500									
Type	Power [kW]	Poles	rpm	I _N [A]	I _A /I _N	M _A /M _N	M _{max} /M _N	J _{rotor} [kgm ²]	Mass [kg]
J3 71A5	0,11	8	670	0,8	2,4	1,4	2	0,00180	6,3
	0,18	4	1370	0,9	3,4	1,1	1,8		
J3 71B5	0,15	8	670	1,1	2,4	1,4	2	0,00200	6,5
	0,3	4	1370	1,2	3,5	1,1	1,8		
J3 80A5	0,22	8	700	1,3	2,4	1,6	2	0,00230	8,7
	0,45	4	1420	1,4	3,5	1,5	1,8		
J3 80B5	0,37	8	700	2	2,6	1,6	2,2	0,00300	8,2
	0,55	4	1410	1,4	3,6	1,5	1,8		
J3 90S5	0,6	8	700	2,8	3,2	1,7	2,2	0,00430	12,5
	1,1	4	1420	2,5	4	2	1,8		
J3 100M5	0,7	8	700	3,5	5	2,5	2,8	0,00770	18
	1,1	4	1430	3	5,2	2,2	2,4		
J3 100L5	1,1	8	710	5	5,2	2,4	2,8	0,00860	20
	1,8	4	1430	4,6	5,5	2,3	2,4		
J3 112M5	1,4	8	710	5,3	5,2	2,5	2,8	0,01200	35
	2,6	4	1430	5,3	5,5	2,3	2,6		
J3 132S5	2,4	8	720	4,8	5,2	2,5	2,8	0,03000	45
	4,5	4	1440	8	5,2	2,3	2,4		
J3 132M5	2,6	8	720	8	5,3	2,5	2,8	0,04000	50
	4,1	4	1430	10,5	5,4	2,3	2,4		
J3 132L5	3	8	720	8,7	5,3	2,4	2,8	0,05500	54
	5,5	4	1440	12	5,4	2,2	2,5		
J3 160M5	4,1	8	720	12,7	5,2	2,4	2,8	0,11200	85
	6,4	4	1440	13,8	5,3	2,2	2,5		

6.2.3 Single-phase motors, 1 speed

SINGLE-PHASE MOTORS 1 SPEED PERMANENT CAPACITOR 230 50Hz 3000												
Type	Power [kW]	rpm	η	cosφ	I _N [A]	M _N [Nm]	I _A /I _N	M _A /M _N	M _{max} /M _N	C [μF]	J _{rotore} [kgm ²]	Mass [kg]
K3 56A2	0,09	2740	65%	0,86	0,7	0,31	2,3	0,6	1,5	3	0,00012	2
K3 56B2	0,12	2760	76%	0,86	0,8	0,42	2,6	0,6	1,5	4	0,00015	2,6
K3 63A2	0,18	2780	76%	0,86	1,2	0,62	2,9	0,6	1,4	4	0,00030	4,3
K3 63B2	0,25	2780	60%	0,9	2	0,86	2,9	0,65	1,5	6	0,00035	4,5
K3 71A2	0,37	2790	50%	0,9	3,6	1,27	3,1	0,7	1,4	10	0,00046	6
K3 71B2	0,55	2800	58%	0,9	4,6	1,88	3,1	0,63	1,4	16	0,00056	6,5
K3 80A2	0,75	2830	59%	0,92	6	2,53	3,2	0,7	1,4	25	0,00097	8
K3 80B2	1,1	2800	64%	0,94	8	3,75	3,3	0,7	1,6	30	0,01000	10
K3 90S2	1,5	2850	71%	0,9	10,2	5,03	3,3	0,6	1,8	40	0,00150	12
K3 90L2	1,5	2850	69%	0,9	10,5	5,03	3,4	0,55	1,5	40	0,00190	14
K3 100M2	2,2	2850	71%	0,9	15	7,38	3,5	0,55	1,7	60	0,00370	23
K3 100L2	3	2850	66%	0,9	22	10,06	3,6	0,6	1,8	80	0,00530	25

SINGLE-PHASE MOTORS 1 SPEED PERMANENT CAPACITOR 230 50Hz 1500												
Type	Power [kW]	rpm	η	cosφ	I _N [A]	M _N [Nm]	I _A /I _N	M _A /M _N	M _{max} /M _N	C [μF]	J _{rotore} [kgm ²]	Mass [kg]
K3 56A4	0,06	1340	53%	0,94	0,9	0,43	2,6	0,6	1,5	2	0,00018	2,6
K3 56B4	0,09	1350	55%	0,95	1	0,64	2,6	0,6	1,5	4	0,00020	2,8
K3 63A4	0,12	1360	58%	0,93	1,3	0,84	2,8	0,63	1,4	4	0,00040	3,4
K3 63B4	0,18	1360	59%	0,95	1,4	1,26	2,8	0,62	1,5	6,3	0,00045	3,6
K3 71A4	0,25	1400	59%	0,94	2,5	1,71	3	0,55	1,4	10	0,00080	6,5
K3 71B4	0,37	1400	59%	0,93	3,6	2,53	3,2	0,56	1,4	10	0,00090	7,2
K3 80A4	0,55	1410	60%	0,94	4,8	3,73	3,2	0,45	1,4	16	0,00096	8
K3 80B4	0,75	1410	63%	0,96	5,4	5,08	3,3	0,5	1,6	20	0,00120	10
K3 90S4	1,1	1400	65%	0,95	8	7,51	3,4	0,45	1,5	30	0,00260	13
K3 90L4	1,5	1410	67%	0,93	10,5	10,16	3,5	0,44	1,8	40	0,00320	15
K3 100M4	2,2	1415	70%	0,96	15,6	14,85	3,8	0,55	1,6	45	0,00590	22

Capacitor: is fitted inside a special 'Ex d' cylindrical box and mounted on the motor.

7. Overall dimensions

B3

Size	B	A	HA	BB	AB	AC	AD	AE	C	H	L	LR	K1	K2	MC	D	E	GA	F	DB
56	71	90	9	90	108	109	107	97	36	56	190	200	6	11	M16	9	20	10,2	3	M3X10
63	80	100	10	105	120	121	113	97	40	63	211	221	7	12	M16	11	23	12,5	4	M4X10
71	90	112	11	108	136	136	122	97	45	71	248	258	7	12	M20	14	30	16	5	M5X25
80	100	125	11	125	154	154	143	111	50	80	273	285	9,5	17,5	M20	19	40	21,5	6	M6X16
90S	100	140	13	130	174	174	148	111	56	90	302	314	9,5	17,5	M20	24	50	27	8	M8X19
90L	125	140	13	155	174	174	188	111	56	90	327	339	9,5	17,5	M20	24	50	27	8	M8X19
100	140	160	14	175	192	192	159	111	63	100	364	376	11,2	21,2	M20	28	60	31	8	M10X22
112	140	190	14	175	224	216	171	111	70	112	387	400	11,2	21,2	M32	28	60	31	8	M10X22
132S	140	216	17,5	180	260	255	195	124	89	132	458	471	12,5	30	M32	38	80	41	10	M12X28
132L	178	216	17,5	218	260	255	195	124	89	132	495	508	12,5	30	M32	38	80	41	10	M12X28
160S	210	254	23	264	318	318	244	186	108	160	597	615	14,5	30	M32	42	110	45	12	M16X36
160L	254	254	23	308	318	318	244	186	108	160	641	659	14,5	30	M32	42	110	45	12	M16X36

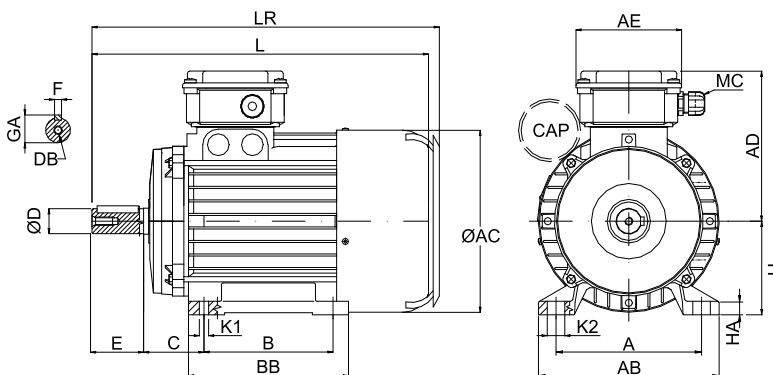

B5

	ØP	ØN	LA	M	T	S
56	120	80	9	100	3	7
63	140	95	11	115	3	9
71	140*	95	11	115	3	9
	160	110	10,5	130	3,5	9
80	160*	110	10,5	130	3,5	9
	200	130	11,5	165	3,5	12
90	160*	110	10,5	130	3,5	9
	200	130	11,5	165	3,5	12
100	200*	130	11,5	165	3,5	12
	250	180	15,5	215	4	14
112	160*	110	10,5	130	3,5	9
	250	180	15,5	215	4	14
132	250*	180	15,5	215	4	14
	300	230	20,7	265	4	14
160	350	250	22	300	5	18

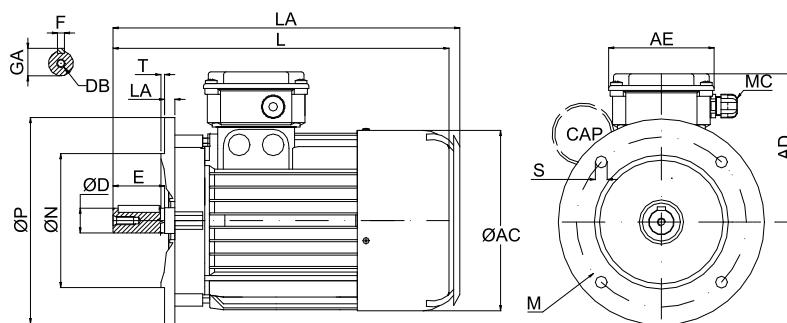

B14

	ØP	ØN	LA	M	T	S
56	80	50	8	65	2,5	M5
63	80*	50	9	65	2,5	M5
	90	60	9	75	2,5	M5
	105*	70	15	85	2,5	M6
71	120*	80	15	100	3	M6
	140*	95	20	115	3	M8
	105*	70	12	85	2,5	M6
80	120	80	12	100	3	M6
	140*	95	20	115	3	M8
	160*	110	20	130	3,5	M8
90	120*	80	15	100	3	M6
	140	95	15	115	3	M8
	160*	110	20	130	3,5	M8
100	120*	80	16	100	3	M6
	160	110	16	130	3,5	M8
	200*	130	20	165	4	M10
112	140*	95	16	115	3	M8
	160	110	16	130	3,5	M8
132	200	130	19	165	4	M10
160	250	180	24	215	4	M12

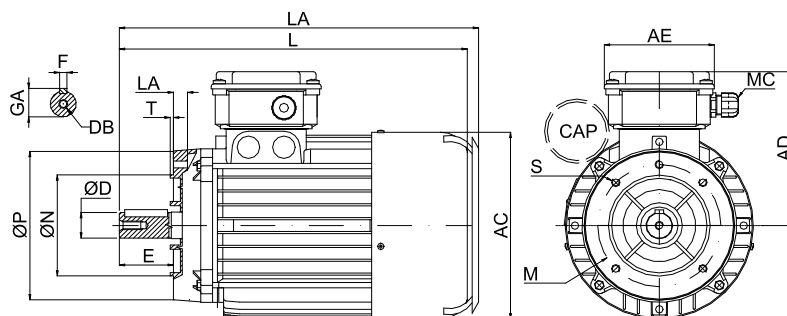

8. Spare parts, overhauls and repairs

8.1 Personnel qualification

Overhauls and repairs must be carried out only by qualified people in accordance with the standard EN 60079-17 or national standards (last edition). Qualified people must have knowledge about explosion protection.

Repairs must be made regarding the rules as define in EN 60079-19 standard.

These repairs can only be done under the control or in agreement with ELPROM or by an ATEX certified workshop.

In case these rules are not respected, the product won't be covered by Elprom ATEX certification anymore.

8.2 Spare parts

All motors components must be replaced with original spare parts. In these case contact ELPROM directly and provide the serial number of the motor in order to be authorized for the repair or the motor itself.

1	Drive end shield (B3) – Flange (B5 – B14)	8	Bearings
2	Frame complete with winding	9	Shaft key
3	Rear shield	10	Wave spring
4	Terminal box	11	Fan (complete of fixing collar)
5	Terminal box cover	12	Fan cover
6	Feet (removable from 63 to 160)	13	Cable gland
7	Shaft complete of rotor	14	Terminal board



Motors for Hazardous Areas



euofins | **Modulo Uno**
EUROFINS - MODULO UNO S.P.A. - VIA CUORGNE', 21 - 10156 TORINO - ITALY
ORGANISMO NOTIFICATO N. 2049

ATTESTATO DI ESAME CE DEL TIPO

[1] **EUM1 12 ATEX 0744**

[2] **Apparecchiature o Sistemi di Protezione destinati ad essere utilizzati in atm esplosive Direttiva 94/9/CE**

[3] Numero dell'Attestato di Esame CE del Tipo:
EUM1 12 ATEX 0744

[4] **Apparecchio:** Motori Elettrici
Serie: J2 - K2
ELPROMTECH S.r.l.

[5] **Costruttore:** Via Mantova, n. 93 - 43122 PARMA (Italia)

[6] **Indirizzo:** Via Mantova, n. 93 - 43122 PARMA (Italia)

[7] Questo apparecchio, e le sue eventuali varianti accettate, sono descritti nell'allegato attestato e nei documenti descrittivi, pure riportati in esso.

[8] EUROFINS-MODULO UNO S.p.A., organismo notificato n. 2049 in conforma Direttiva 94/9/CE del Consiglio dell'Unione Europea del 23 marzo 1994, certifica sono conformi ai requisiti essenziali di sicurezza e salute per il progetto apparecchiature destinate ad essere utilizzate in atmosfere potenzialmer nell'Allegato II della Direttiva.

[9] Gli esami ed i risultati di prova sono registrati nel rapporto a carattere riservato n. La conformità ai Requisiti Essenziali di Sicurezza e Salute è assicurata tramite ve conformità alle:
EN 60079-0:2009; EN 60079-1:2007; EN 60079-7:2007; EN 60079

[10] Il simbolo "X" posto dopo il numero dell'attestato indica che l'apparecchio è speciali per un utilizzo sicuro, specificate nell'allegato al presente attestato.

[11] Questo ATTESTATO DI ESAME CE DEL TIPO è relativo soltanto al progetto, a dell'apparecchio, specificato in accordo con la Direttiva 94/9/CE.

[12] L'apparecchio deve includere il simbolo ed almeno una delle stringhe seg

II 2G Ex e IIC T3 Gb	Tamb -40°C + 55°C
II 2G Ex e IIC T4 Gb	Tamb -40°C + 40°C
II 2G Ex ed IIC T3 Gb	Tamb -40°C + 55°C
II 2G Ex ed IIC T4 Gb	Tamb -40°C + 40°C
II 2G Ex eb IIC T3	Tamb -40°C + 55°C
II 2G Ex eb IIC T4	Tamb -40°C + 40°C
II 2G Ex eb db IIC T3	Tamb -40°C + 55°C
II 2G Ex eb db IIC T4	Tamb -40°C + 40°C
II 2D Ex tb IIIC T125°C IP65	Tamb -40°C + 55°C

Torino, 14 Maggio 2012

Dionisio Bucchieri
Responsabile della Direttiva

Paolo Dentis
Notified Body Manager

Il presente Attestato non sostituisce in alcun modo la dichiarazione di conformità, né esonera il Costruttore da altri obblighi di legge per quanto a Cgia modifica nella progettazione o realizzazione può rendere non valido il presente attestato e richiede comunicazione all'Organismo. La documentazione applicabili al prodotto. La modifica delle norme di riferimento fa decadere la validità della presente Attestato. Il presente Attestato è composto da 1 pagin

euofins | **Modulo Uno**
EUROFINS - MODULO UNO S.P.A. - VIA CUORGNE', 21 - 10156 TORINO - ITALY
ORGANISMO NOTIFICATO N. 2049

TYPE EXAMINATION CERTIFICATE

[1] **EUM1 12 ATEX 0109**

[2] **Equipments or protective systems or components intended for use in potentially explosive atmospheres Directive 94/9/EC**

[3] Number of Type examination certificate:
EUM1 12 ATEX 0109

[4] **Equipment:** Electrical Motors
Series: J3 - K3
ELPROMTECH S.r.l.

[5] **Manufacturer:** Via Mantova, 93 - 43122 PARMA (Italia)

[6] **Address:** Via Mantova, 93 - 43122 PARMA (Italia)

[7] This equipment and any acceptable variation thereto are specified in the annex to this certificate and the documents reported in it.

[8] EUROFINS-MODULO UNO S.p.A., notified body n. 2049 in accordance with Article 9 of the Council Directive 94/9/CE of 23th March 1994, certifies that this component have been found to comply with the Essential Health and Safety Requirements relating to the design and construction of component intended for use in potentially explosive atmospheres given in Annex II of the Directive. The examination and test results are recorded in the confidential report n. M1.12.REL.02/48070

[9] Compliance with the essential health and safety is assured by compliance with:
EN 60079-0:2009; EN 60079-15:2010; EN 60079-31:2009

[10] The sign "X" is placed after the certificate number, it indicates that the equipment is subject to special conditions for safe use specified in the annex to this certificate.

[11] This TYPE EXAMINATION CERTIFICATE relates only to the design, the exam and the tests of the equipment specified, in accordance with the Directive 94/9/CE.

[12] The equipment shall include the sign and at least one of the following strings:

II 3G Ex nA IIC T3 Gc	Tamb -20°C + 40°C
II 3G Ex nA IIC T4 Gc	Tamb -20°C + 40°C
II 3G Ex nAd IIC T3 Gc	Tamb -20°C + 40°C
II 3G Ex nAd IIC T4 Gc	Tamb -20°C + 40°C
II 3G Ex nAc IIC T3	Tamb -20°C + 40°C
II 3G Ex nAc IIC T4	Tamb -20°C + 40°C
II 3G Ex nAc db IIC T3	Tamb -20°C + 40°C
II 3G Ex nAc db IIC T4	Tamb -20°C + 40°C
II 3D Ex tc IIIB T125°C IP55	Tamb -20°C + 40°C

Turin, 14 May 2012

Dionisio Bucchieri
Directive Responsible

Paolo Dentis
Notified Body Manager

Declaration of conformity nor exonerate the Manufacturer from product liability. This certificate and requires a communication to the body. The technical documentation do not refers to others directives applicable to the scope of the certificate. This certificate has one page and is reproducible only in its entirety. The notified body of the original document drawn in Italian; only the Italian text is legally valid.

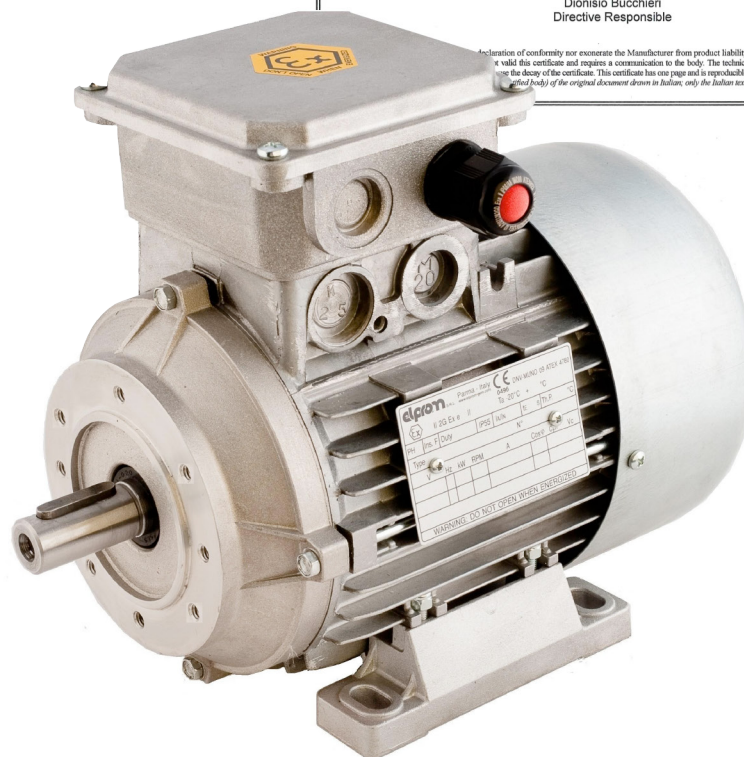



www.orange1.eu

Manufactured by
ELPROMtech Srl
Via Mantova, 93
43122 - Parma
Italy

info@orange1.eu

Tel. +39 0521 272383
Fax +39 0521 272686

ORANGE[®]

