

IE2 APPROVED

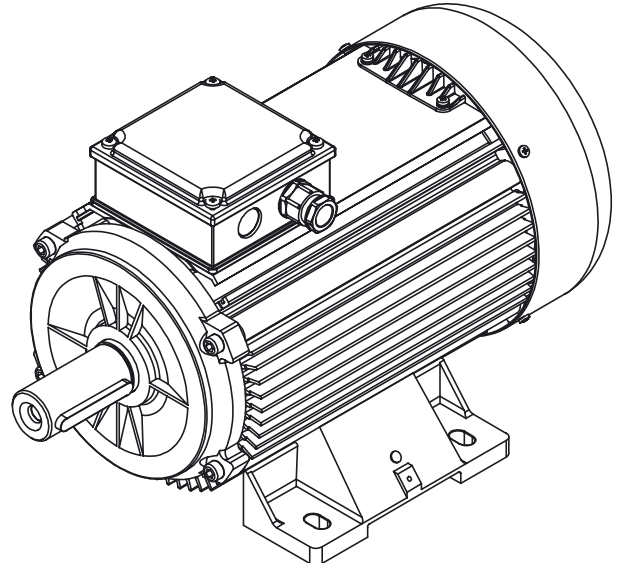

Electric Motors Europe



COMPRESSORS

TRIFASE - THREE PHASE - DREIPHASIG - TRIFÁSICO - TRIPHASÉ
MONOFASE - SINGLE PHASE - EINPHASIG - MONOFÁSICO - MONOPHASÉ

11

- MMSTD
- MD
- MTSTD
- MTHES

EME Group nel corso degli anni ha acquisito una importante esperienza nell'ambito di settori specifici, lo sviluppo di motori elettrici con caratteristiche personalizzate in funzione dell'applicazione è la fonte di questo catalogo. Uno strumento che si propone quale guida indispensabile per i produttori di compressori. Abbiamo raccolto in un unico manuale la gamma di motori elettrici che generalmente vengono utilizzati per i compressori dividendola in Motori Monofase MMSTD, Motori Monofase con condensatore di spunto MD e Motori Trifase MT

La gamma MMSTD è prodotta con condensatore di marcia perennemente inserito. Nella gamma MD inseriamo un condensatore aggiuntivo per aumentare la coppia di avviamento Proponiamo la gamma MT in due versioni STD e HES. Il motore standard trifase MTSTD è sviluppato per soddisfare le prestazioni di rendimento indicate dalla Direttiva Europea (EUP) N.640/2009 che prescrive obblighi sui rendimenti minimi ed identificata con la sigla IE1. Abbiamo inoltre aggiunto il motore Trifase HES (High Energy Saving) che riflette i rendimenti indicati dalla stessa Direttiva Europea con la sigla IE2.

Tutti i motori per compressori sono disponibili (su richiesta e con sovrapprezzo) con omologazione UL e CSA essendo costruiti e marcati in conformità ai requisiti di sicurezza stabiliti dai due principali Organismi di controllo nordamericano: file di identificazione E1176350 per UL e LR109925 per CSA.

The large know how of EME Group comes from the experience done in several markets, the development of custom made electric motors tailed for specific applications is the origin of this manual. This catalogue would like to be a useful guide for the compressors' manufacturers.

The electric motors used for compressors have been collected in a unique file listing the Single Phase motors MMSTD, the Single Phase motors with high starting torque MD and the Three Phases motors MT.

MMSTD range includes a run capacitor permanently connected. Into the MD range to increase the starting torque we connect an addition capacitor. MT range is available in two versions STD and HES. The standard MT is made to meet the efficiency performances established by the European Directive (EUP) N.640/2009 defined as IE1. We offer additionally the Three Phases HES (High Energy Saving) meeting the efficiency standards defined as IE2.

All the electric motors are available (upon request subject to addition costs) with UL-CSA approval when manufactured and marked in accordance with the safety requirements determined by the two main North American Control Bodies: E1176350 identification for UL and LR109925 for CSA.

MMSTD

B3 (B6 - B7 - B8 - V5 - V6)

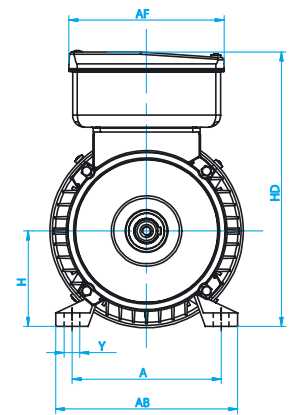
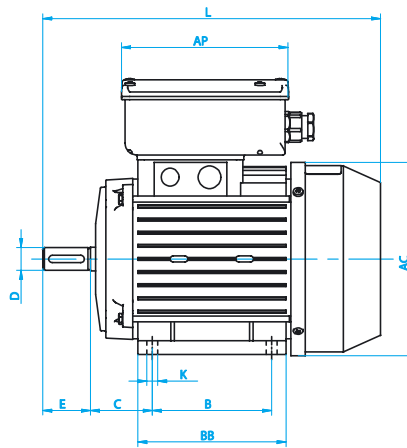

B14 (V18 - V19)

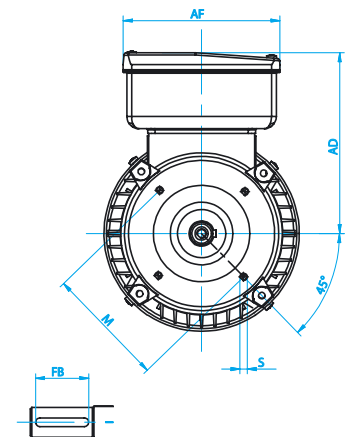
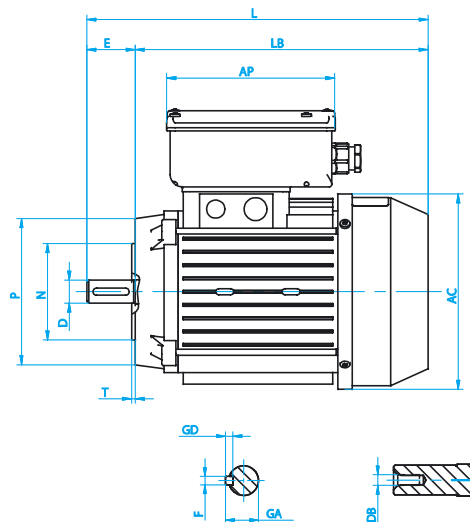

Tolerances (DIN 748-7160-7161-42948)		
D	≤ 28 mm	j6
	38 ÷ 50 mm	k6
	> 50 mm	m6
N	≤ 230 mm	j6
	> 230 mm	h6
H	≤ 250 mm	+0 / -0,5 mm
	> 250 mm	+0 / -1 mm

MMSTD: Monofase - Single Phase - Einphasig - Monofásico - Monophasé

SIZE	B3														B14												
	A	AB	B	BB	C	D	E	H	HD	L	K	Y	AC	AD	AF	AP	F	FB	GA	GD	DB	P	N	M	T	S	LB
M80	125	150	100	125	50	19	40	80	230	282	9	15	162	150	130	140	6	30	21,5	6	M6	120	80	100	3	M6	242
M90L	140	170	125	155	56	24	50	90	242	326	10	15	180	152	130	140	8	40	27	7	M8	140	95	115	3	M8	276

SIZE	Pn		n	In (230V)	Cosφ	η	Mn	Ms	Ms/Mn	Cm (450V)	Cs (400V)	Acc	J	Kg
	kW	Hp												
MMSTD 3000 min⁻¹ 2 POLI 50 Hz														
M80	1,1	2	2783	7,9	0,88	69,1	3,77	3,2	0,85	45	0	24,5	0,00101	10,3
M80	1,5	2	2760	9,7	0,96	69,7	5,19	3,8	0,73	45	0	28,5	0,00125	11,9
M80-S6-60%	2,2	3	2730	13,2	0,97	74,7	7,70	4,1	0,53	50	0	39,5	0,00136	12,7
M90L	2,2	3	2824	12,9	0,96	77,4	7,44	4,6	0,62	66	0	50,0	0,00205	17,9

LEGENDA SIMBOLI Legend - Zeichenerklärung - Explicación símbolos - Légende des symboles

SIZE	grandezza	frame size	Größe	tamaño	hauteur d'axe
Pn	potenza nominale	rated power	Nennleistung	potencia nominal	puissance nominale
n	velocità nominale	rated speed	Nennzahl	velocidad nominal	vitesse nominale
In	corrente nominale	rated current	Nennstrom	corriente nominal	courant nominal
Cosφ	fattore di potenza	power factor	Leistungsfaktor	factor de potencia	facteur de puissance
h	rendimento	efficiency	Wirkungsgrad	rendimiento	rendement
Mn	coppia nominale	rated torque	Nennmoment	par nominal	couple nominal
Ms	coppia di spunto	stand-still torque	Anlaufmoment	par de arranque	couple initial de démarrage
Cm	condensatore di marcia	run capacitor	Betriebskondensator	condensador de arranque	condensateur de marche
Cs	condensatore di spunto	start capacitor	Anlaufkondensator	condensador de arranque	condensateur de démarrage
Acc	corrente di spunto	locked-rotor current	Anlaufstrom	corriente inicial de arranque	courant initial de démarrage
J	momento d'inerzia	inertia	Trägheitsmoment	momento de inercia	moment d'inertie
kg	peso	weight	Gewicht	peso	poids

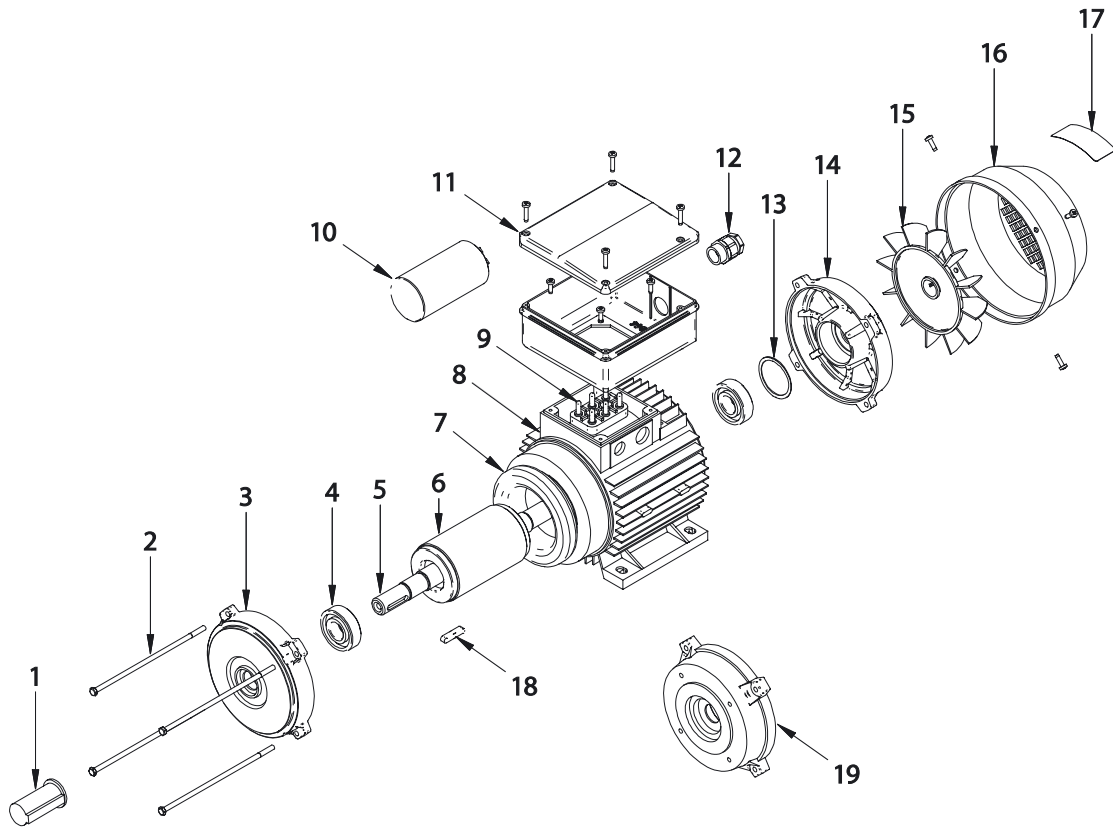

1	Coprialbero - Shaft protection - Wellenschutz Protección eje - Couvre arbre
2	Tirante - Screw - Schraube - Tornillo - Vis
3	Scudo anteriore - End shield (drive end) - vorderes Gehäuseschild - Escudo delantero - Flasque avant
4	Cuscinetto - Bearing - Lager - Cojinete - Roulement
5	Albero motore - Shaft - Welle - Eje - Arbre
6	Rotore - Rotor Rotor - Rotor - Rotor
7	Statore avvolto - Stator assembly - gewickelter Stator Estator bobinado - Stator enroulé

8	Carcassa motore - Frame - Gehäuse - Carcasa Carcasse moteur
9	Morsetteria - Terminal board - Klemmenleisten Bornera - Plaque à bornes
10	Condensatore - Condenser - Kondensator Condensador - Condensateur
11	Coprimorsetteria - Terminal box - Klemmenleistenabde- ckung - Caja de bornes - Boîte à bornes
12	Pressacavo - Cable gland - Kabelschelle Prensa estopas - Presse-étoupe
13	Anello di compensazione - Pre-load washer - Kompensation- sring - Anillo de compensacion - Bague de compensation
14	Scudo posteriore - End-shield (non-drive end) hinteres Gehäuseschild - Escudo trasero - Flasque arrière

15	Ventola di raffreddamento - Cooling fan - Kühlventilator Ventilador - Ventilateur
16	Copriventola - Fan Cover - Lüfterhaube Tapa ventilador - Couvre ventilateur
17	Targa motore - Nameplate - Etiketle - Placa - Plaque
18	Linguetta di trascinamento - Shaft key - Schlüssel Chaveta de tracción - Clavette
19	Flangia B14 - B14 flange - B14 Flansch Brida B14 - Bride B14

B3 (B6 - B7 - B8 - V5 - V6)

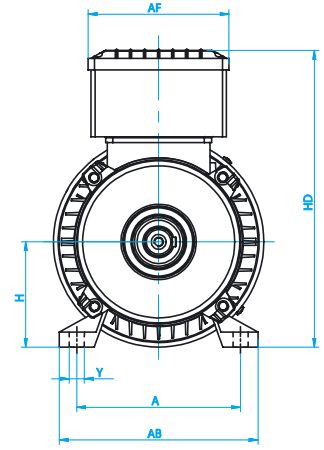
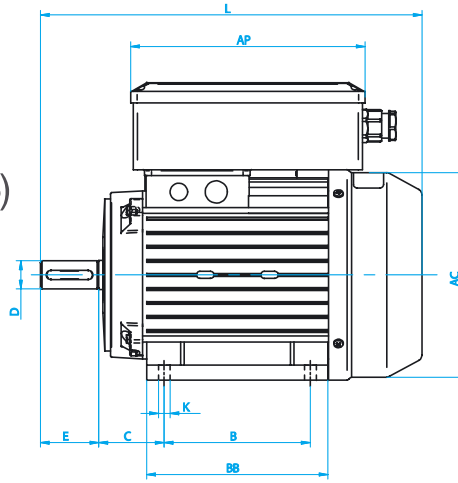

B14 (V18 - V19)

Tolerances (DIN 748-7160-7161-42948)

D	≤ 28 mm	j6
	38 ÷ 50 mm	k6
	> 50 mm	m6
N	≤ 230 mm	j6
	> 230 mm	h6
H	≤ 250 mm	+0 / -0,5 mm
	> 250 mm	+0 / -1 mm

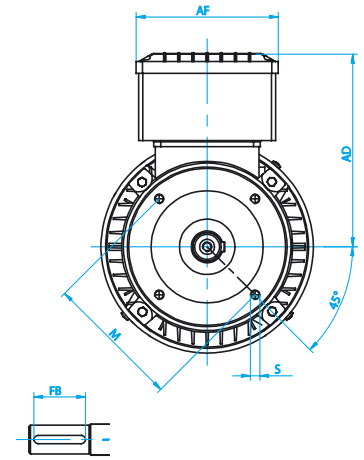
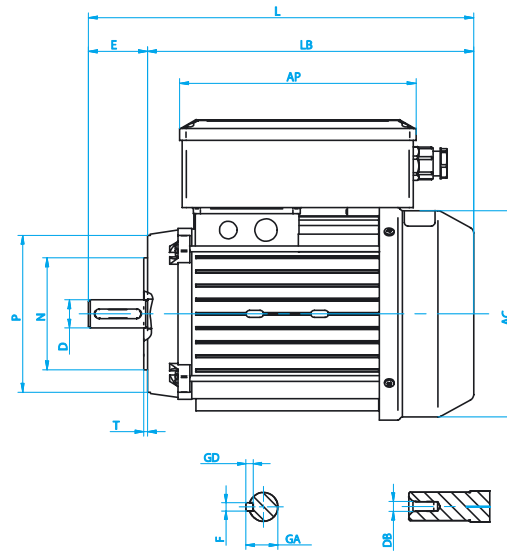

MD: Monofase - Single Phase - Einphasig - Monofásico - Monophasé

SIZE	B3																	B14									
	A	AB	B	BB	C	D	E	H	HD	L	K	Y	AC	AD	AF	AP	F	FB	GA	GD	DB	P	N	M	T	S	LB
MD90L	140	170	125	155	56	24	50	90	254	326	10	15	180	164	120	200	8	40	27	7	M8	140	95	115	3	M8	276
MDE100c	160	196	140	180	63	28	60	100	233	367	12	21	176	133	130	140	8	50	31	7	M10	160	110	130	3,5	M8	307

SIZE	Pn		n	In (230V)	Cosφ	η	Mn	Ms	Ms/Mn	Cm (450V)	Cs (400V)	Acc	J	Kg
	kW	Hp	min-1	A		%	Nm	Nm		μF	μF	A	Kgm2	
MD 3000 min⁻¹ 2 POLI 50 Hz														
MD90L	2,2	3	2845	12,5	0,97	78,7	7,38	11	1,49	66	90	54	0,00205	18,2
MD90L	3,0	4	2865	16,7	0,99	78,8	10,00	12	1,20	90	90	68	0,00220	18,7
MDE100c	3,0	4	2865	16,7	0,99	78,8	10,00	12	1,20	90	90	38	0,00220	19,7

LEGENDA SIMBOLI Legend - Zeichenerklärung - Explicación símbolos - Légende des symboles

SIZE	grandezza	frame size	Größe	tamaño	hauteur d'axe
Pn	potenza nominale	rated power	Nennleistung	potencia nominal	puissance nominale
n	velocità nominale	rated speed	Nennzahl	velocidad nominal	vitesse nominale
In	corrente nominale	rated current	Nennstrom	corriente nominal	courant nominal
Cosφ	fattore di potenza	power factor	Leistungsfaktor	factor de potencia	facteur de puissance
h	rendimento	efficiency	Wirkungsgrad	rendimiento	rendement
Mn	coppia nominale	rated torque	Nennmoment	par nominal	couple nominal
Ms	coppia di spunto	stand-still torque	Anlaufmoment	par de arranque	couple initial de démarrage
Cm	condensatore di marcia	run capacitor	Betriebskondensator	condensador de arranque	condensateur de marche
Cs	condensatore di spunto	start capacitor	Anlaufkondensator	condensador de arranque	condensateur de démarrage
Acc	corrente di spunto	locked-rotor current	Anlaufstrom	corriente inicial de arranque	courant initial de démarrage
J	momento d'inerzia	inertia	Trägheitsmoment	momento de inercia	moment d'inertie
kg	peso	weight	Gewicht	peso	poids

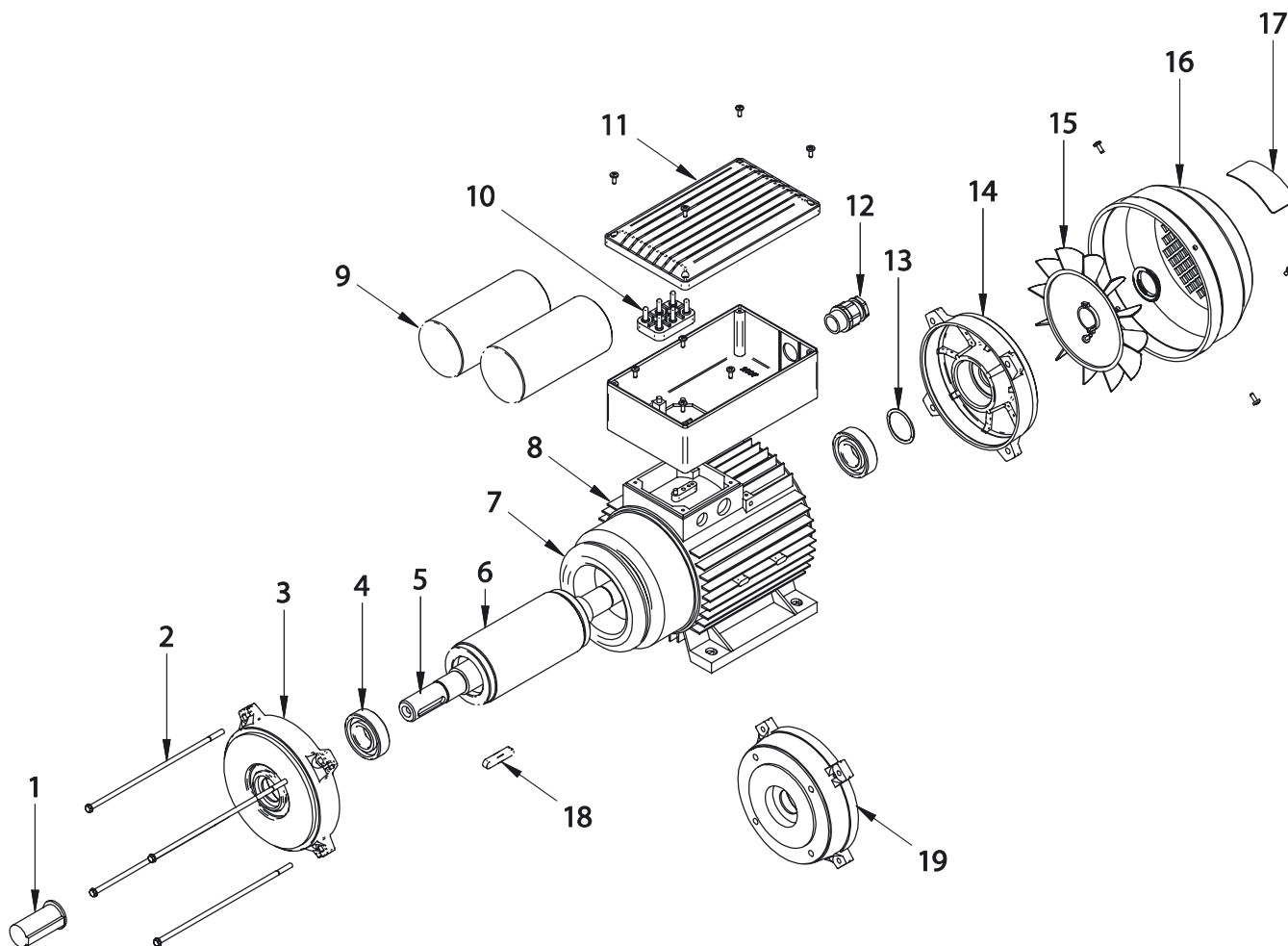

1	Coprialbero - Shaft protection - Wellenschutz Protección eje - Couvre arbre
2	Tirante - Screw - Schraube - Tornillo - Vis
3	Scudo anteriore - End shield (drive end) - vorderes Gehäuseschild - Escudo delantero - Flasque avant
4	Cuscinetto - Bearing - Lager - Cojinete - Roulement
5	Albero motore - Shaft - Welle - Eje - Arbre
6	Rotore - Rotor Rotor - Rotor - Rotor
7	Statore avvolto - Stator assembly - gewickelter Stator Estator bobinado - Stator enroulé
8	Carcassa motore - Frame - Gehäuse - Carcasa Carcasse moteur
9	Condensatore - Condenser - Kondensator Condensador - Condensateur
10	Morsettiera - Terminal board - Klemmenleisten Bornera - Plaque à bornes

11	Coprimorsettiera - Terminal box - Klemmenleistenabde- ckung - Caja de bornes - Boîte à bornes
12	Pressacavo - Cable gland - Kabelschelle Prensa estopas - Presse-étoupe
13	Anello di compensazione - Pre-load washer - Kompensation- sring - Anillo de compensación - Bague de compensation
14	Scudo posteriore - End-shield (non-drive end) hinteres Gehäuseschild - Escudo trasero - Flasque arrière
15	Ventola di raffreddamento - Cooling fan - Kühlventilator Ventilador - Ventilateur
16	Copriventola - Fan Cover - Lüfterhaube Tapa ventilador - Couvre ventilateur
17	Targa motore - Nameplate - Etikette - Placa - Plaque
18	Linguetta di trascinamento - Shaft key - Schlüssel Chaveta de tracción - Clavette
19	Flangia B14 - B14 flange - B14 Flansch Brida B14 - Bride B14

MTSTD - MTHES

B3 (B6 - B7 - B8 - V5 - V6)

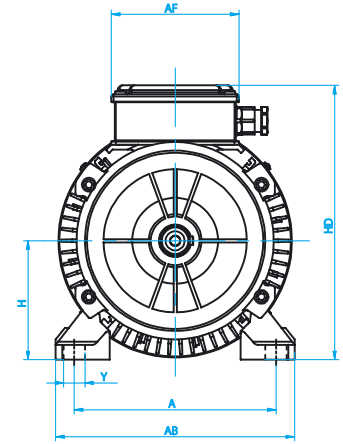
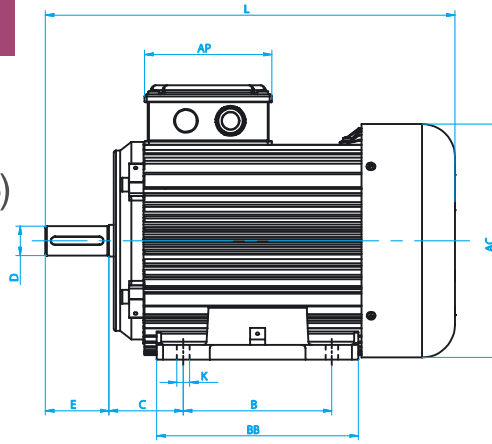

B14 (V18 - V19)

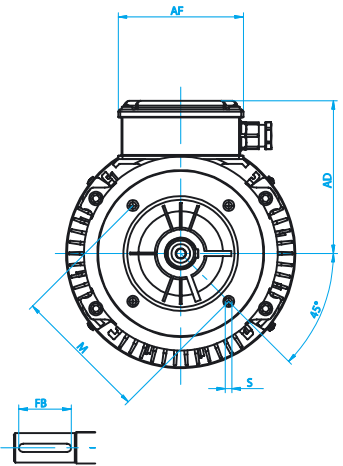
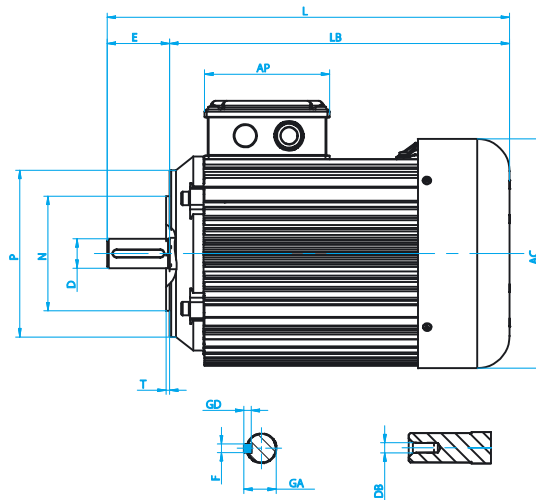

Tolerances (DIN 748-7160-7161-42948)		
D	≤ 28 mm	j6
	38 ÷ 50 mm	k6
	> 50 mm	m6
N	≤ 230 mm	j6
	> 230 mm	h6
H	≤ 250 mm	+0 / -0,5 mm
	> 250 mm	+0 / -1 mm

MTSTD: Trifase - Three Phase - Dreiphasig - Trifásico - Triphasé IE1

SIZE	B3															B14											
	A	AB	B	BB	C	D	E	H	HD	L	K	Y	AC	AD	AF	AP	F	FB	GA	GD	DB	P	N	M	T	S	LB
MT80	125	150	100	125	50	19	40	80	197	300	9	15	155	117	102	102	6	30	21,5	6	M6	120	80	100	3	M6	260
MT90Lc	140	165	125	145	56	24	50	90	207	315	9	15	155	117	102	102	8	40	27	7	M8	140	95	115	3	M8	265
MT100c	160	196	140	180	63	28	60	100	221	367	12	21	176	121	102	102	8	50	31	7	M10	160	110	130	3,5	M8	307
MT112c	190	225	140	180	70	28	60	112	241	388	12	20	194	129	102	102	8	50	31	7	M10	160	110	130	3,5	M8	328
MT132Sc	216	263	140	190	89	38	80	132	279	469	12	20	220	147	120	120	10	70	41	8	M12	200	130	165	3,5	M10	389
MT132Mc	216	263	178	218	89	38	80	132	279	492	12	20	220	147	120	120	10	70	41	8	M12	200	130	165	3,5	M10	412
MT132M	216	256	178	218	89	38	80	132	294	526	12	20	258	162	133	133	10	70	41	8	M12	200	130	165	3,5	M10	446
MT160Mc	254	300	210	256	108	42	110	160	322	556	15	23	258	162	133	133	12	90	45	8	M16	250	180	215	4	M12	446
MT160Lc	254	300	254	300	108	42	110	160	322	625	15	23	258	162	133	133	12	90	45	8	M16	250	180	215	4	M12	515

MTHES: Trifase - Three Phase - Dreiphasig - Trifásico - Triphasé IE2

SIZE	B3															B14											
	A	AB	B	BB	C	D	E	H	HD	L	K	Y	AC	AD	AF	AP	F	FB	GA	GD	DB	P	N	M	T	S	LB
HES80	125	150	100	125	50	19	40	80	197	300	9	15	155	117	102	102	6	30	21,5	6	M6	120	80	100	3	M6	260
HES90Lc	140	165	125	145	56	24	50	90	207	315	9	15	155	117	102	102	8	40	27	7	M8	140	95	115	3	M8	265
HES100c	160	196	140	180	63	28	60	100	221	367	12	21	176	121	102	102	8	50	31	7	M10	160	110	130	3,5	M8	307
HES100c	160	196	140	180	63	28	60	100	221	367	12	21	176	121	102	102	8	50	31	7	M10	160	110	130	3,5	M8	307
HES112c	190	225	140	180	70	28	60	112	241	388	12	20	194	129	102	102	8	50	31	7	M10	160	110	130	3,5	M8	328
HES132Sc	216	263	140	190	89	38	80	132	279	469	12	20	220	147	120	120	10	70	41	8	M12	200	130	165	3,5	M10	389
HES132M	216	256	178	218	89	38	80	132	294	526	12	20	258	162	133	133	10	70	41	8	M12	200	130	165	3,5	M10	446
HES160Mc	254	300	210	256	108	42	110	160	322	556	15	23	258	162	133	133	12	90	45	8	M16	250	180	215	4	M12	446
HES160Lc	254	300	254	300	108	42	110	160	322	625	15	23	258	162	133	133	12	90	45	8	M16	250	180	215	4	M12	515

SIZE	Pn		n	In (400V)	Cosφ	η	Mn	J	peso	UL	CSA
	kW	Hp									
MTSTD 3000 min⁻¹ 2 POLI IE1											
MT80	1,5	2	2872	3,27	0,808	81,9	4,99	0,00131	12,1	X	X
MT90Lc	2,2	3	2876	4,62	0,822	83,6	7,30	0,00153	14,2	X	X
MT100c	3,0	4	2880	6,34	0,805	84,9	9,95	0,00237	18,8	X	X
MT100c	4,0	5,5	2879	8,00	0,841	85,8	13,27	0,00255	19,7	X	X
MT112c	4,0	5,5	2880	8,22	0,817	86,0	13,26	0,00394	24,7	X	X
MT112c	5,5	7,5	2885	10,79	0,845	87,1	18,20	0,00505	28,1	X	X
MT132Sc	5,5	7,5	2890	10,67	0,851	87,4	18,17	0,00682	29,8	X	X
MT132Sc	7,5	10	2912	14,14	0,868	88,2	24,59	0,00820	32,8	X	X
MT132M	11,0	15	2922	20,75	0,855	89,5	35,95	0,01940	57,2	X	X
MT132M	15,0	20	2930	27,37	0,875	90,4	48,89	0,02339	65,5	X	X
MT160Mc	11,0	15	2922	20,75	0,855	89,5	35,95	0,02010	57,2	X	X
MT160Mc	15,0	20	2930	27,37	0,875	90,4	48,89	0,02396	65,5	X	X
MT160Lc	18,5	25	2928	32,97	0,888	91,2	60,34	0,02893	78,5	X	X

SIZE	Pn		n	In (400V)	Cosφ	η	Mn	J	peso	UL	CSA
	kW	Hp									
MTHES 3000 min⁻¹ 2 POLI IE2											
HES80	1,5	2	2850	3,58	0,790	76,5	5,00	0,00108	11,0	X	X
HES90Lc	2,2	3	2890	4,96	0,790	81,0	7,40	0,00142	12,6	X	X
HES100c	3,0	4	2879	6,56	0,810	81,5	9,95	0,00237	18,8	X	X
HES100c	4,0	5,5	2870	8,75	0,790	83,5	13,31	0,00255	19,7	X	X
HES112c	4,0	5,5	2900	8,58	0,810	83,1	13,17	0,00328	22,6	X	X
HES112c	5,5	7,5	2910	11,39	0,822	84,8	18,05	0,00477	26,4	X	X
HES132Sc	5,5	7,5	2910	11,25	0,840	84,0	18,05	0,00636	32,0	X	X
HES132Sc	7,5	10	2900	14,72	0,868	84,7	24,70	0,00820	32,8	X	X
HES132Mc	11,0	15	2935	21,82	0,845	86,1	35,79	0,01001	47,8	X	X
HES132M	11,0	15	2941	21,30	0,855	87,2	35,72	0,01864	48,9	X	X
HES132M	15,0	20	2910	28,48	0,860	88,4	49,00	0,02260	62,2	X	X
HES160Mc	11,0	15	2920	21,30	0,855	87,2	36,00	0,01927	51,2	X	X
HES160Mc	15,0	20	2910	28,48	0,860	88,4	49,00	0,02313	62,2	X	X
HES160Lc	18,5	25	2905	34,85	0,860	89,1	60,00	0,02700	70,0	X	X
HES160Lc	22,0	30	2918	39,51	0,890	90,3	72,00	0,02893	79,0	X	X

LEGENDA SIMBOLI Legend - Zeichenerklärung - Explicación símbolos - Légende des symboles

SIZE	grandezza	frame size	Größe	tamaño	hauteur d'axe
Pn	potenza nominale	rated power	Nennleistung	potencia nominal	puissance nominale
n	velocità nominale	rated speed	Nennzahl	velocidad nominal	vitesse nominale
In	corrente nominale	rated current	Nennstrom	corriente nominal	courant nominal
Cosφ	fattore di potenza	power factor	Leistungsfaktor	factor de potencia	facteur de puissance
h	rendimento	efficiency	Wirkungsgrad	rendimiento	rendement
Mn	coppia nominale	rated torque	Nennmoment	par nominal	couple nominal
J	momento d'inerzia	inertia	Trägheitsmoment	momento de inercia	moment d'inertie
kg	peso	weight	Gewicht	peso	poids
UL/CSA	varianti con sovrapprezzo	versions with extra price	Ausführungen mit Aufpreis	variante con sobreprecio	p variantes avec majoration eso

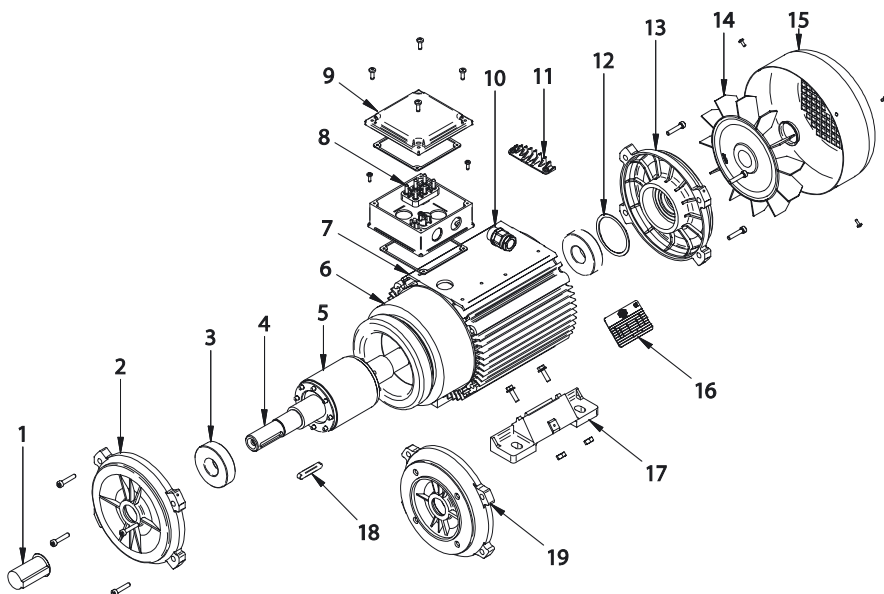

1	Coprialbero - Shaft protection - Wellenschutz - Protección eje Couvre arbre
2	Scudo anteriore - End shield (drive end) - vorderes Gehäuseschild Escudo delantero - Flasque avant
3	Cuscinetto - Bearing - Lager - Cojinete - Roulement
4	Albero motore - Shaft - Welle - Eje - Arbre
5	Rotore - Rotor - Rotor - Rotor - Rotor
6	Statore avvolto - Stator assembly - gewickelter Stator Estator bobinado - Stator enroulé
7	Carcassa motore - Frame - Gehäuse - Carcasa - Carcasse moteur
8	Morsettiere - Terminal board - Klemmenleisten - Bornera - Plaque à bornes
9	Coprimorsettiere - Terminal box - Klemmenleistenabdeckung Caja de bornes - Boîte à bornes
10	Pressacavo - Cable gland - Kabelschelle - Prensa estopos - Presse-étoupe
11	Protezione ventola - Blower Protection - Gebläse Schutz Protection de ventilateur - Protección del ventilador
12	Anello di compensazione - Pre-load washer - Kompensationsring Anillo de compensación - Bague de compensation
13	Scudo posteriore - End-shield (non-drive end) - hinteres Gehäuseschild Escudo trasero - Flasque arrière
14	Ventola di raffreddamento - Cooling fan - Küh ventilator Ventilador - Ventilateur
15	Copri ventola - Fan Cover - Lüfterhaube Tapa ventilador - Couvre ventilateur
16	Targa motore - Nameplate - Etikette - Placa - Plaque
17	Piede carcassa - Foot - Gehäusefuss - Pata - Pattes
18	Linguetta di trascinamento - Shaft key - Schlüssel Chaveta de tracción - Clavette
19	Flangia B14 - B14 flange - B14 Flansch - Brida B14 - Bride B14

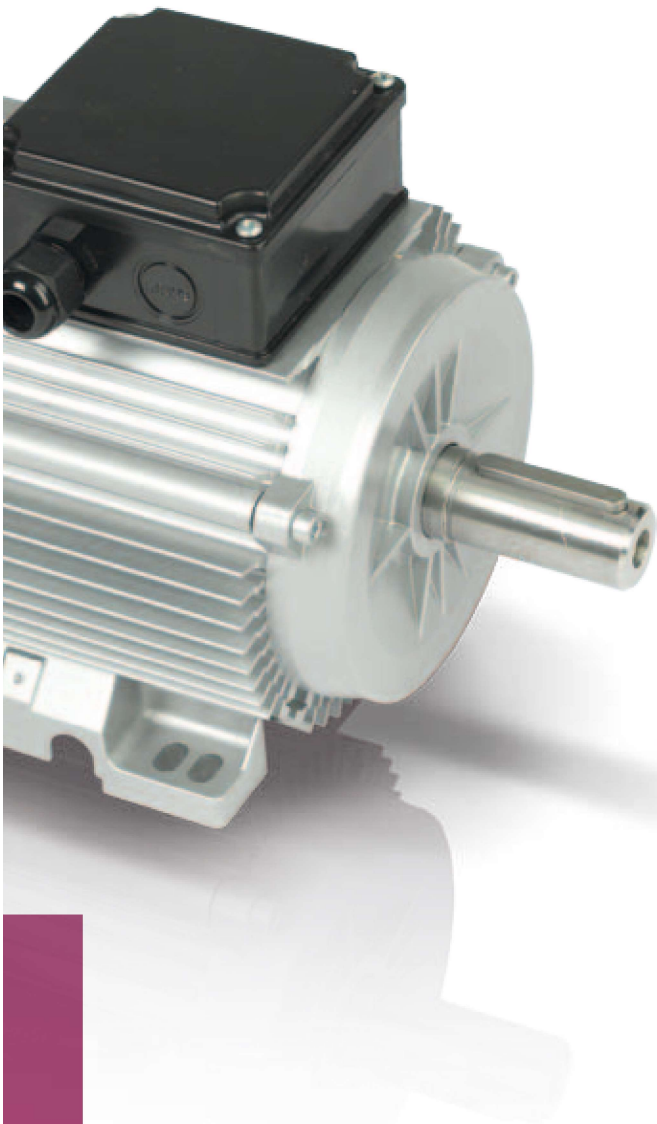

STANDARD PRODUTTIVO

Manufacturing standard - Produktionsstandard
Estándar de producción - Standard de production

Tensione nominale Rated voltage Nennspannung Tensión nominal Tension nominale	MT 230/400V 50Hz (Pn ≤ 3 kW) 400/690V 50Hz (Pn ≥ 4 kW) MM 230V 50Hz
Grado di protezione Protection degree Schutzgrad Grado de protección Degré de protection	IP54
Cuscinetti Bearings Kugellager Rodamientos Paliers	ZZ
Classe di isolamento Insulation class Isolierungsklasse Clase de aislamiento Classe d'isolement	F
Servizio Duty Service Servicio Service	S1
Installazione e forma costruttiva Mounting arrangement Installation und Bauform Instalación y forma de construcción Montage et formes de construction	IM B3 basetta superiore IM B3 top terminal Hochwertige IM B3-Klemmen Tablero superior IM B3 Plaque à bornes supérieure IM B3
Carcassa Frame Gehäuse Carcasa Carcasse	Alluminio estruso Extruded aluminum Extrudierten Aluminium Aluminium extrudé De aluminio extruido
Coprimorsettiera Terminal box Klemmenkasten Caja de bornes Couver boîtier	due componenti (base+coperchio) two components (base + cover) zwei -Komponenten (Basis+Abdeckung) dos componentes (base + tapa) deux éléments (base+couvercle)
Copriventola Fan cover Lüfterhaube Tapa ventilador Garde-ventilateur	Lamiera zincata Galvanized steel sheet Verzinktes Blech Plancha galvanizada Tôle galvanisée

PRESSACAVO

Cable gland - Kabelschelle - Prensa estopas - Presse-étoupe

M56 M71	1 M16 x 1,5
M80 M90s	1 M20 x 1,5
M90L M132M	1 M25 x 1,5
M160M M180L	2 M32 x 1,5

Tutte le tabelle riportano valori e dimensioni indicative. EME Spa e CEG Srl si riservano il diritto di modificarle senza preavviso - All the charts include approximate values and dimensions. EME Spa and CEG Srl reserve the right to modify values and/or dimensions without notice
Alle Tabellen enthalten nur Richtwerte und Richtmasse. EME Spa und CEG behalten sich das Recht vor, diese Werte und/oder Masse jederzeit ohne Mitteilung abzuändern - Todas las tablas incluyen valores y dimensiones aproximados. EME Spa y CEG Srl se reservan el derecho de modificar valores y/o dimensiones sin previo aviso - Tous les tableaux incluent valeurs et dimensions approximatives. EME Spa et CEG Srl se réservent le droit de modifier valeurs et/ou dimensions sans prévenir.



Electric Motors Europe

EME S.p.A.
Zona Industriale
32030 Arsiè (BL) Italy
Phone +39 0439 750.067
Fax +39 0439 750.070
info@orange1.eu
www.emespa.it



CEG S.r.l.
Via A. Grandi, 23
47030 San Mauro Pascoli (FC) Italy
Phone +39 0541 815.611
Fax +39 0541 815.684
info@orange1.eu
www.ceg.it