

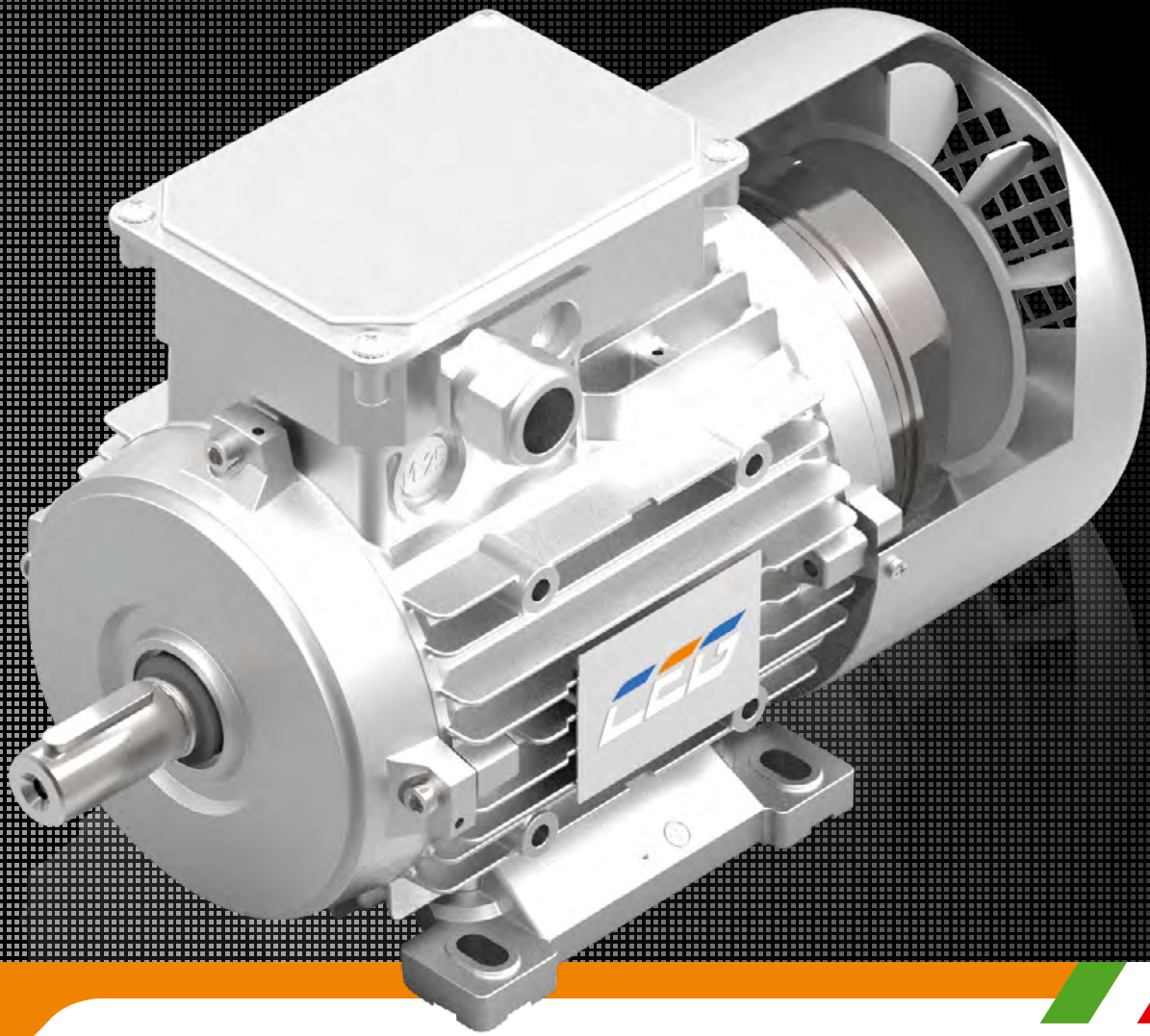

— FROM PROJECT TO PASSION —



High Torque Brake Motors

Three Phase - Single Phase **Technical Datasheets**

EN



ORANGE1 HOLDING

A dynamic, strong and ambitious Group:

Orange1 Holding is an international renown Group, one of the most important European manufacturers of single-phase and three-phase asynchronous electric motors. It has an annual capacity of more than 1 million motors and 5 million electric stators with an annual turnover of approx 200 million euro and more than 1200 workers in 11 production facilities. The group, established in 1971 by Leone Donazzan, chaired today by his son Armando Donazzan, is strongly focused on technological innovation, performance and customization to meet individual clients requirements. As a group of 13 companies it has a powerful advantage: the strength in numbers.



CEG Srl, member of Orange1 Group since 2008, was founded in 1971 as a family-run electromechanical company. CEG Srl has built, over the years, a proper and specific industrial dimension thanks to continuous investments in technology and logistics. The company has a young, motivated and highly skilled workforce. The deep technical knowledge gained over many years of experience combined with the use of technologically advanced tools make the company a reliable partner. Flexibility and efficiency have enabled the company to meet all customers requests by providing personalized solutions for specific applications. This steady commitment for product customization has led to a remarkable technological and process development.

Company's products are targeted to the following applications: wood working machinery wind turbine generators, pumps, foodstuffs machinery, textile machinery, machinery for the chemical industry, wine sector and automation. Ceg Srl is well known for its brake motors and low centre motors.

High Torque Brake Motors

To provide the motor with high-torque braking power so to achieve precise, sudden positioning and stationary results, CEG proposes two distinct solutions: a DC brake (FHC) and a AC brake (FHA), to be selected on the basis of the characteristics of the application. As shown in the Tables given there is an opportunity for manufacturing - upon request subject to additional cost - versions compliant with the following regulations:

UL – CSA approved: the motor is manufactured with approved materials and equipped with a plate bearing the exclusive certification marks of this regulation. The ID files attributed to CEG approved products are E176350 for UL certification and LR109925-1 for CSA certification.

ATEX Directive: the motor is manufactured with ATEX-compliant materials and manufacturing standards and is equipped with a plate bearing the ATEX exclusive mark. CEG recommends the usage of 3GD motors in Zone 2 and Zone 22.



CABLE GLAND

M56 ÷ M90	1 M20 x 1,5
M90L ÷ M112	1 M25 x 1,5
M132M	1 M25 x 1,5
M160 ÷ M180	2 M32 x 1,5

MANUFACTURING STANDARD

rated voltage	MT 230/400V 50Hz (Pn ≤ 3 kW) - 400/690V 50Hz (Pn ≥ 4 kW) DP 400V 50Hz / MM 230V 50Hz	
rated voltage brake	FHC 230V (Pn ≤ 3 kW) / 400V (Pn ≥ 4 kW)	FHA 230/400V
Rectifier (FHC)	Half wave or full wave	
Protection degree	IP54	
Bearings	2RS	
insulation class	F	
Duty	S1	
Mounting arrangement	IM B3 top terminal	
Frame	Aluminium pressure die casting, removable feet	
Terminal box	Two aluminium FH components (base + cover)	
Fan cover	Galvanized steel sheet	
Painting	Not painted	
Balancing	Full key	

High Torque Brake Motors



CEG self-braking motors are suitable in positioning and stationary applications where passive processing times need to be reduced in compliance with safety regulations. In both FHC and FHA brake models the braking torque is given by the pressure exerted by springs operating on a double friction surface disc. To release the brake energize the electromagnet coil of the brake. FHA brakes are generally more suited to applications with high intervention frequency. Rectifiers capable of reducing intervention times of FHC brakes are available upon request. Brake connection: to terminal block or through power unit separate from the motor.

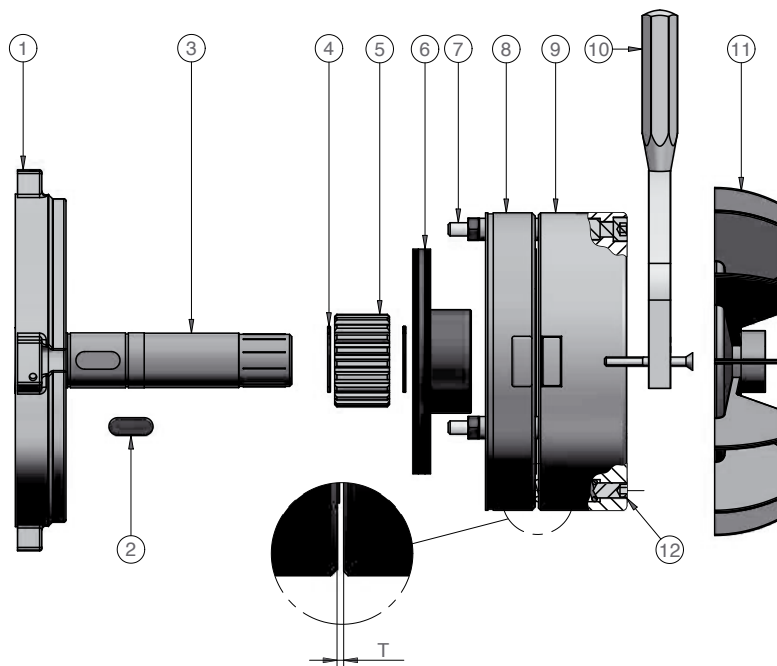

1	FH end-shield
2	Key
3	Shaft
4	Circlip
5	Driving hub
6	Friction pad
7	Air gap adjustment screw
8	Mobile anchor
9	Brake coil
10	Hand release lever (on demand)
11	Cooling fan (PVC)
12	Braking torque adjustment screw (FHA)

Size	Braking torque		Power		Closing Time		Release time		Braking gap	
	Nm		W		ms		ms		mm	
	FHC	FHA	FHC	FHA	FHC	FHA	FHC	FHA	FHC	FHA
M56	1		8		20		30		0,15	
M63	5	5	15	17	10	>10	45	>10	0,2	0,2
M71	5	5	15	17	10	>10	45	>10	0,2	0,2
M80	10	10	20	35	15	>10	50	>10	0,2	0,2
M90	25	27	30	48	15	>10	65	>10	0,2	0,2
M100	42	40	45	50	20	>10	75	>10	0,3	0,3
M112	60	60	50	65	25	>10	180	>10	0,3	0,3
M132	120	120	55	69	50	>10	200	>10	0,3	0,3
M160	200	150	60	134	60	>10	210	>10	0,3	0,3
M180	400	300	60	134	60	>10	210	>10	0,4	0,4

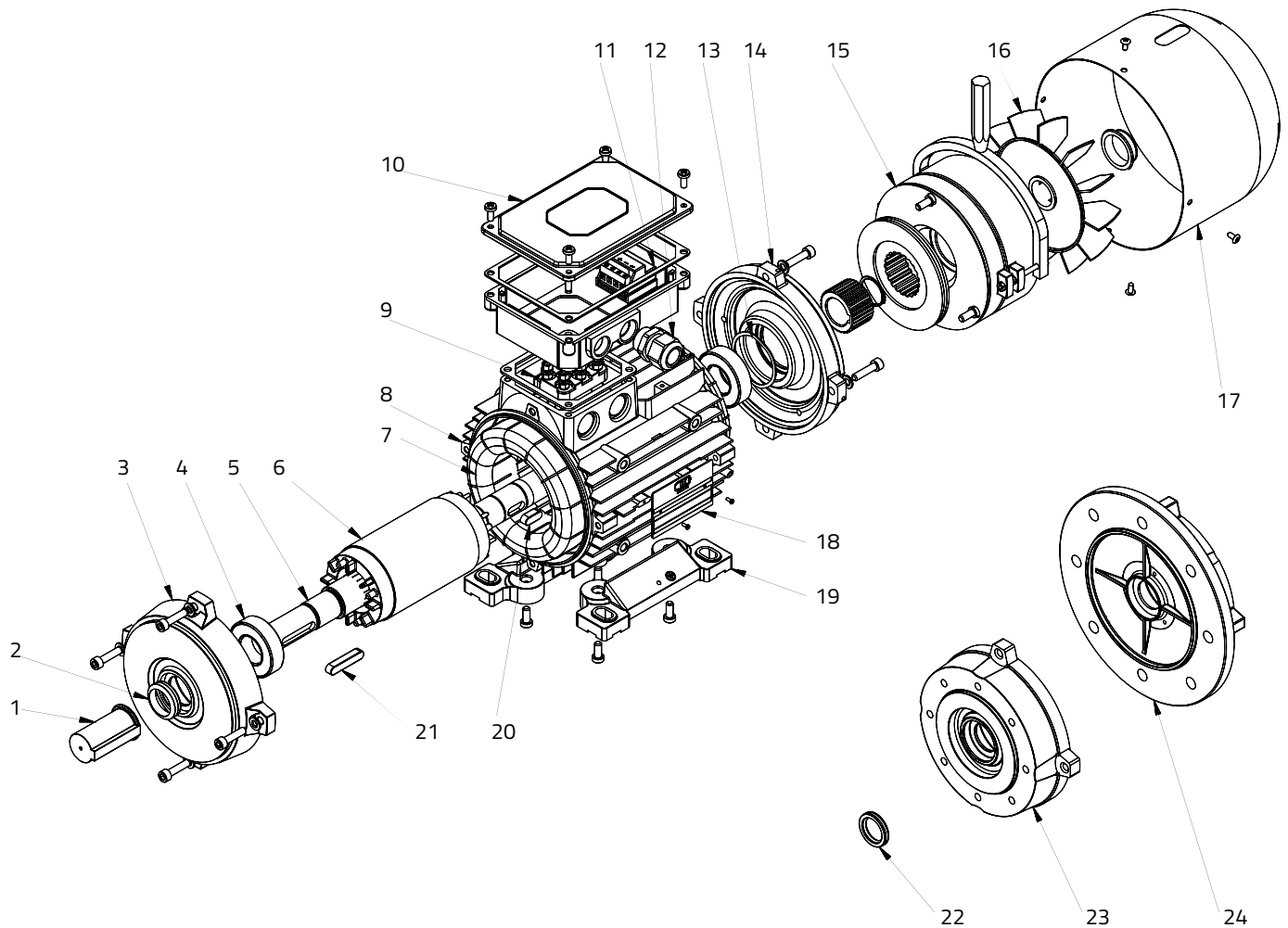

1	Shaft protection	13	Pre-load washer
2	Dust seal (V-ring)	14	End-shield (non-drive end)
3	End-shield (drive end)	15	Brake group
4	Bearing	16	Cooling fan (PVC)
5	Shaft	17	FH Fan cover
6	Rotor	18	Nameplate
7	Stator assembly	19	Foot
8	Casing	20	Shaft key
9	Terminal board	21	Driving hub key
10	Terminal box	22	Oil seal
11	Brake terminal block	23	B14 flange
12	Cable gland	24	B5 Flange

Legend

size	Pn	n	In	Cosφ	η	Mn	Mm
frame size	rated power	rated speed	rated current	power factor	efficiency	rated torque	maximum torque
Ms	Is	Cm	J	kg	UL / CSA / ATEX		
stand-still torque	locked-rotor current	run capacitor	inertia	weight	versions with extra price		

MTFH

THREE PHASE motors one speed with high torque brake

SIZE	Pn		n	In(400V)	Cosφ	η	Mn	Mm/Mn	Ms/Mn	Is/In	J	kg	UL	CSA	ATEX**
	kW	Hp	min ⁻¹	A		%	Nm				kgm ²				
3000 min⁻¹ 2 poles 50Hz															
M56a	0,09	0,12	2765	0,33	0,72	55	0,31	3	2,9	3,5	0,00008	3,4	x	x	x
M56b	0,135	0,18	2830	0,58	0,58	58	0,46	4	4	3,8	0,00008	4,2	x	x	x
M63a	0,185	0,25	2810	0,59	0,71	64	0,63	2,9	2,6	3,9	0,00049	5,1	x	x	x
M63b	0,25	0,35	2840	0,78	0,68	68	0,84	3,3	3,4	4,5	0,00051	5,4	x	x	x
M71a	0,37	0,5	2820	1,08	0,75	66	1,25	3	2,8	4,3	0,00064	7,1	x	x	x
M71b	0,55	0,75	2800	1,38	0,8	72	1,88	2,7	2,5	4,5	0,00074	7,8	x	x	x
M80a	0,75	1	2790	1,90	0,79	72	2,57	3,3	3,4	5,3	0,00149	10,6	x	x	x
M80b	1,1	1,5	2815	2,82	0,77	73	3,73	3,2	2,9	4,8	0,00161	11,7	x	x	x
M80c	1,5	2	2800	3,80	0,78	73	5,12	3,1	3,1	4,8	0,00178	12,7	x	x	x
M90Sa	1,5	2	2850	3,61	0,78	77	5,03	3,4	3	3	0,00216	14,5	x	x	x
M90Sb	1,85	2,5	2830	4,51	0,79	75	6,24	3	2,9	5,1	0,00216	15	x	x	x
M90La	2,2	3	2810	4,67	0,85	80	7,48	3	2,8	5,6	0,00238	17,3	x	x	x
M90Lb	3	4	2850	6,29	0,83	83	10,05	3,1	3,1	6,1	0,00265	19,5	x	x	x
M100La	3	4	2860	6,52	0,83	80	10,02	3,4	3,2	6,2	0,00476	23	x	x	x
M100Lb	4	5,5	2875	8,49	0,81	84	13,29	3,7	3,2	7,7	0,00577	27,5	x	x	x
M112Ma	4	5,5	2895	9,14	0,79	80	13,19	3,5	3,1	6,2	0,00609	29,2	x	x	x
M112Mb	5,5	7,5	2885	11,95	0,81	82	18,20	3,6	3,6	6,7	0,00726	35,5	x	x	x
M132Sa	5,5	7,5	2900	11,96	0,83	80	18,11	3,4	3	6	0,014	44,3	x	x	x
M132Sb	7,5	10	2920	15,34	0,83	85	24,53	3,9	3,3	7,4	0,0156	50	x	x	x
M132Ma	11	15	2920	21,8	0,83	87	36	3,7	3,3	7	0,0172	58	x	x	x
M160Ma	11	15	2940	20,74	0,86	89	35,73	3,4	2,7	7,7	0,0384	79	x	x	x
M160Mb	15	20	2955	28,95	0,85	88	48,47	4	3,6	8,5	0,0458	93	x	x	x
M180M	22	30	2945	39,20	0,9	90	71,33	3,5	2,7	8,6	0,063	120	x	x	x
1500 min⁻¹ 4 poles 50Hz															
M56b	0,09	0,12	1330	0,48	0,63	43	0,65	2,2	2,2	2,1	0,00011	4,1	x	x	x
M63a	0,135	0,18	1330	0,56	0,66	53	0,97	2,2	2,2	2,5	0,000524	5	x	x	x
M63b	0,185	0,25	1340	0,71	0,67	56	1,32	2,2	2,2	2,7	0,000564	5,7	x	x	x
M71a	0,25	0,35	1400	0,86	0,68	62	1,71	2,8	2,7	3,7	0,00186	7,5	x	x	x
M71b	0,37	0,5	1375	1,16	0,73	63	2,57	2,6	2,5	4	0,00112	8	x	x	x
M71c	0,55	0,75	1350	1,65	0,74	65	3,89	2,2	2,2	3,5	0,00087	7,7	x	x	x
M80a	0,55	0,75	1390	1,50	0,79	67	3,78	2	1,7	3,9	0,00234	10,5	x	x	x
M80b	0,75	1	1405	2,06	0,73	72	5,01	2,4	2,3	5	0,00277	12	x	x	x
M80c	1,1	1,5	1400	2,76	0,8	72	7,50	2,2	2	4,4	0,00342	14,3	x	x	x
M90S	1,1	1,5	1370	2,76	0,81	71	7,67	2,1	2,1	4,3	0,00291	14,5	x	x	x
M90La	1,5	2	1410	3,90	0,74	75	10,16	3	2,9	4,6	0,0034	16,9	x	x	x
M90Lb	1,85	2,5	1400	4,50	0,77	77	12,62	2,7	2,7	5	0,0038	18,5	x	x	x
M100La	2,2	3	1420	5,43	0,77	76	14,79	2,5	2,1	4,6	0,00935	21,5	x	x	x
M100Lb	3	4	1410	6,94	0,79	79	20,32	2,7	2,6	5,3	0,00728	24,9	x	x	x
M100Lc	4	5,5	1400	8,93	0,84	77	27,28	2,4	2,2	4,5	0,00773	26,8	x	x	x
M112Ma	4	5,5	1420	8,80	0,81	81	26,90	2,9	2,4	5,2	0,00957	31,7	x	x	x
M132S	5,5	7,5	1430	10,99	0,85	85	36,73	2,3	2,1	5,1	0,0245	49,5	x	x	x
M132Ma	7,5	10	1445	16,52	0,78	84	49,56	2,6	2,5	5,3	0,0287	60	x	x	x
M160M	11	15	1455	21,76	0,82	89	72,19	2,6	2,3	5,5	0,06038	86,2	x	x	x
M160L	15	20	1460	30,07	0,8	90	98,11	2,3	2,3	5,5	0,07431	104,5	x	x	x
M180Ma	18,5	25	1465	35,35	0,83	91	120,58	2,5	2,5	5,9	0,087	154	x	x	x
M180Mb	22	30	1450	42,04	0,83	91	144,88	2,5	2,5	5,9	0,096	160	x	x	x

** Only FHC version

THREE PHASE motors one speed with high torque brake

SIZE	Pn		n min ⁻¹	In(400V) A	Cosφ	η %	Mn Nm	Mm/Mn	Ms/Mn	Is/In	J kgm ²	kg	UL	CSA	ATEX**
	kW	Hp													
1000 min-1 6 poles 50Hz															
M63b	0,12	0,17	850	0,67	0,65	40	1,35	1,8	1,8	1,8	0,00059	6,2	x	x	x
M71a	0,185	0,25	900	0,86	0,62	50	1,96	2,1	2,1	2,5	0,00112	7,7	x	x	x
M71b	0,25	0,35	900	1,11	0,65	50	2,65	1,8	1,8	2,4	0,00134	9,2	x	x	x
M80a	0,37	0,5	880	1,23	0,79	55	4,02	1,8	1,7	2,8	0,0025	10,5	x	x	x
M80b	0,55	0,75	875	1,62	0,79	62	6,00	1,8	1,7	3,1	0,00296	12,2	x	x	x
M90S	0,75	1	915	2,15	0,71	71	7,83	2,3	2,2	3,7	0,00389	14	x	x	x
M90L	1,1	1,5	900	3,16	0,75	67	11,67	2,2	2,2	3,3	0,00373	16,7	x	x	x
M100L	1,5	2	950	4,37	0,66	75	15,08	2,6	2,4	4,2	0,00827	22,5	x	x	x
M112M	2,2	3	950	5,15	0,79	78	22,11	2,5	1,7	5,1	0,01625	33,7	x	x	x
M132S	3	4	955	7,50	0,78	74	30,00	2,5	1,6	4,7	0,0284	44,5	x	x	x
M132Ma	4	5,5	950	9,03	0,78	82	40,21	2,5	1,8	5,1	0,03194	54,2	x	x	x
M132Mb	5,5	7,5	950	11,96	0,8	83	55,28	2,3	1,4	2,9	0,03721	60	x	x	x
M160M	7,5	10	960	15,74	0,8	86	74,60	2,5	2,3	5	0,0839	85	x	x	x
M160L	11	15	970	23,79	0,75	89	108,29	3,7	2,8	6,4	0,14137	117	x	x	x
750 min-1 8 poles 50Hz															
M71	0,135	0,18	630	0,77	0,6	42	2,05	2	2	2	0,00087	7,5	x		x
M80a	0,185	0,25	690	0,96	0,57	49	2,56	2,2	1,9	2,3	0,0025	10,9	x		x
M80b	0,25	0,35	670	1,16	0,62	50	3,56	1,8	1,7	2,3	0,00296	12,2	x		x
M90S	0,37	0,5	650	1,49	0,63	57	5,44	1,5	1,3	2,1	0,00309	14,8	x		x
M90L	0,55	0,75	650	2,17	0,63	58	8,08	1,7	1,7	2,3	0,0034	16,5	x		x
M100La	0,75	1	690	2,52	0,67	64	10,38	1,9	1,4	3	0,00828	21,5	x		x
M100Lb	1,1	1,5	690	3,59	0,67	66	15,22	1,8	1,5	3	0,00981	25,8	x		x
M112M	1,5	2	700	4,97	0,65	67	20,46	2	1,6	3	0,01451	31	x		x
M132S	2,2	3	720	5,94	0,66	81	29,18	2,5	1,5	4,1	0,03194	49,3	x		x
M132M	3	4	720	7,32	0,73	81	39,79	2,6	1,3	4,9	0,03721	56,5	x		x
M160Ma	4	5,5	730	10,97	0,65	81	52,32	2,2	2,1	4	0,0839	91	x		x
M160Mb	5,5	7,5	720	15,27	0,65	80	72,94	2,9	2,4	4,5	0,010816	97	x		x
M160L	7,5	10	710	16,96	0,76	84	100,87	2,1	1,5	4	0,11715	117	x		x
M180L	11	15	730	26,93	0,67	88	143,89	3,2	2,2	4,5	0,09353	90	x		x

** Only FHC version

THREE PHASE motors two speed with high torque brake

SIZE	Pn		n	In(400V)	Cosφ	η	Mn	J	kg	UL	CSA	ATEX**
	kW	Hp	min ⁻¹	A		%	Nm	kgm ²				
3000 / 1500 min⁻¹ 2/4 poles 50Hz												
M56	0,11/0,07	0,15/0,1	2720-1370	0,41-0,33	0,75-0,6	52-52	0,39-0,49	0,00012	3,8	x	x	x
M63	0,22/0,15	0,3/0,2	2760-1400	0,67-0,57	0,88-0,63	54-60	0,76-1,02	0,00059	5,7	x	x	x
M71a	0,3/0,22	0,4/0,3	2900-1445	1,2-1	0,62-0,57	58-56	0,99-1,45	0,00112	7,8	x	x	x
M71b	0,55/0,37	0,75/0,5	2830-1405	1,3-1,25	0,82-0,62	75-69	1,86-2,51	0,00065	8,8	x	x	x
M80a	0,6/0,45	0,8/0,6	2840-1415	1,7-1,3	0,77-0,74	65-65	2,02-3,04	0,00191	12	x	x	x
M80b	0,8/0,6	1,1/0,8	2875-1420	2,14-2,05	0,77-0,64	70-66	2,67-4,03	0,00212	12,2	x	x	x
M80c	1,1/0,75	1,5/1	2865-1420	2,77-2,45	0,82-0,66	70-67	3,67-5,04	0,00231	13,7	x	x	x
M90Sa	1,5/1,1	2/1,5	2840-1420	4,1-2,86	0,75-0,72	70-77	5,04-7,4	0,00309	15,2	x	x	x
M90Sb	1,85/1,25	2,5/1,7	2800-1410	4,5-3,1	0,82-0,76	73-77	6,31-8,47	0,0034	16,7	x	x	x
M90La	2,2/1,5	3/2	2830-1410	4,9-3,4	0,87-0,82	75-78	7,4-10,2	0,00375	19	x	x	x
M100La	3/2,2	4/3	2840-1410	7,1-5,3	0,82-0,78	74-77	10,1-14,9	0,00632	23,1	x	x	x
M100Lb	4/3	5,5/4	2850-1400	9,4-6,7	0,85-0,83	72-78	13,4-20,5	0,00719	26,5	x	x	x
M112M	4,5/3,3	6/4,5	2865-1430	10,6-7,6	0,88-0,8	70-78	15-22	0,01158	35,2	x	x	x
M132Sa	5,5/4,5	7,5/6	2915-1450	12,9-9,9	0,82-0,81	77-81	18-29,6	0,02456	46,5	x	x	x
M132Sb	7,5/6	10/8	2910-1445	18-12,9	0,78-0,82	77-82	24,6-39,6	0,02727	50	x	x	x
M132M	8,1/6,6	11/9	2915-1440	17,5-14,4	0,88-0,85	76-78	26,5-43,8	0,02871	57,4	x	x	x
M160M	11/9	15/12	2970-1480	25,8-19,4	0,75-0,77	82-87	35,4-58,1	0,06513	107	x	x	x
M160L	14/11	19/15	2950-1470	32-23,4	0,76-0,77	83-88	45,3-71,5	0,07431	114	x	x	x
M180M	18,5/15	25/20	2950-1460	42,3/31,6	0,76-0,77	83-89	59,9-98,1	0,087	130,7	x	x	x
1500 / 750 min⁻¹ 4/8 poles 50Hz												
M71	0,185/0,09	0,25/0,12	1440-700	0,74-0,97	0,66/0,57	55-25	1,23-1,23	0,00134	11	x	x	x
M80a	0,37/0,2	0,5/0,28	1400-700	0,96-1,1	0,86-0,61	65-43	2,52-2,73	0,00296	12,2	x	x	x
M80b	0,55/0,3	0,75/0,4	1375-685	1,35-1,65	0,85-0,61	69-43	3,82-4,18	0,00318	12,4	x	x	x
M90S	0,75/0,37	1/0,5	1360-680	1,76-1,74	0,88-0,58	70-53	5,26-5,2	0,00309	15,2	x	x	x
M90L	1/0,5	1,35/0,7	1375-690	2,2-2,3	0,88-0,56	74-56	6,94-6,92	0,0034	16,5	x	x	x
M100La	1,4/0,66	1,9/0,9	1400-680	3,2-2,5	0,85-0,6	75-63	9,55-9,27	0,00632	22	x	x	x
M100Lb	1,6/0,9	2,2/1,2	1360-680	3,75-3,3	0,88-0,65	70-60	11,2-12,6	0,00728	24,5	x	x	x
M112Ma	1,85/1,1	2,5/1,5	1420-720	4-4,1	0,87-0,62	76-63	12,4-14,6	0,01159	27	x	x	x
M112Mb	2,2/1,4	3/1,9	1440-720	4,6-4,4	0,89-0,66	78-69	14,6-18,6	0,01625	33,7	x	x	x
M132S	3,7/2	5/2,8	1450-720	7,15-6,7	0,9-0,59	83-73	24,4-26,5	0,03194	49,5	x	x	x
M132M	5,1/3	7/4	1435-720	10,1-9,4	0,91-0,63	80-73	33,9-39,8	0,03721	56,3	x	x	x
M160Ma	6/4	8/5,5	1450-725	12,7-11,7	0,86-0,61	79-81	39,5-52,7	0,0839	84,9	x	x	x
M160Mb	7,5/5	10/6,8	1420-715	15,3-12,7	0,9-0,71	79-80	50,4-66,8	0,0839	84,9	x	x	x
M160L	10/7	14/9	1450-720	20,5-18,6	0,88-0,67	80-81	65,9-92,8	0,1052	111	x	x	x
1500 / 1000 min⁻¹ 4/6 poles 50Hz												
M71	0,3/0,22	0,4/0,3	1430-830	1,2-0,9	0,7-0,74	60-50	2-2,5	0,00137	7,9	x	x	x
M80	0,55/0,37	0,75/0,5	1450-940	1,7-1,27	0,7-0,7	67-60	3,62-3,76	0,00338	13,7	x	x	x
M90S	0,75/0,55	1/0,75	1445-945	2,1-1,8	0,77-0,75	66-60	5-5,5	0,00309	15,2	x	x	x
M90L	1,1/0,75	1,5/1	1420-925	2,77-2,37	0,8-0,74	72-62	7,4-7,74	0,0045	16,9	x	x	x
M100L	1,5/0,9	2/1,2	1465-965	4,3-2,65	0,7-0,7	72-70	9,8-8,9	0,00981	25,5	x	x	x
M112Ma	1,85/1,32	2,5/1,8	1465-965	4,6-3,6	0,8-0,75	72-70	12-12,9	0,01451	31,7	x	x	x
M112Mb	2,2/1,5	3/2	1460-970	5,1-4,1	0,85-0,75	73-70	14,4-14,8	0,01625	34,2	x	x	x
M132S	3,3/2,2	4,5/3	1460-970	7,3-5,7	0,83-0,71	79-78	21,6-21,7	0,03176	40,5	x	x	x
M132Ma	4/2,5	5,5/3,5	1455-970	9,3-7	0,79-0,66	79-78	26,3-24,6	0,03194	50,5	x	x	x
M132Mb	5,5/4	7,5/5,5	1460-975	11,1-10	0,87-0,75	82-77	36-39,2	0,03721	57,5	x	x	x
M160M	7,5/5	10-6,8	1470-960	15-11	0,84-0,82	86-80	48,7-49,7	0,10816	97	x	x	x
1000 / 750 min⁻¹ 6/8 poles 50Hz												
M80	0,25/0,14	0,35/0,19	920-685	0,98-0,75	0,78-0,71	47-38	2,6-1,95	0,00134	14,2	x	x	x
M90L	0,55/0,25	0,75/0,35	920-700	1,6-1,1	0,77-0,68	65-48	5,71-3,41	0,00425	17,2	x	x	x
M100L	0,95/0,55	1,3/0,75	960-700	2,93-1,9	0,72-0,7	65-60	9,5-7,5	0,00828	26,5	x	x	x
M112M	1,5/0,75	2/1	965-730	4,1-2,53	0,72-0,68	73-63	14,8-9,8	0,01622	33,7	x	x	x
M132S	2,2/1,1	3/1,5	960-740	6,1-3,6	0,72-0,78	73-65	22-14,2	0,03275	63,5	x	x	x
M132M	3/1,85	4/2,5	975-715	8,3-4,9	0,68-0,72	77-76	29,4-24,7	0,03543	67,5	x	x	x

** Only FHC version

SINGLE PHASE motors with high torque DC brake

SIZE	Pn		n min ⁻¹	In- (400V) A	Cosφ	η %	Mn Nm	Mm/Mn	Ms/Mn	Is/In	J kgm ²	kg	UL	CSA	ATEX**
	kW	Hp													
3000 min⁻¹ 2 poles 50Hz															
M56	0,11	0,15	2680	1	0,94	50	0,39	1,2	1,9	6,3	0,00008	3,3	x	x	x
M63a	0,185	0,25	2700	1,55	0,94	55	0,65	0,85	2,4	8	0,00014	4,4	x	x	x
M63b	0,25	0,35	2750	2,2	0,88	56	0,87	1	2,7	10	0,00024	4,6	x	x	x
M71a	0,37	0,5	2700	3,2	0,84	61	1,31	0,67	2,8	12	0,0004	6,6	x	x	x
M71b	0,55	0,75	2730	4,3	0,92	61	1,92	0,62	2,8	16	0,00038	7,7	x	x	x
M80a	0,75	1	2770	5,1	0,94	68	2,58	0,83	3,6	20	0,00066	10	x	x	x
M80b	1,1	1,5	2750	7,1	0,96	70	3,82	0,55	3,5	25	0,00083	11,4	x	x	x
M80c	1,5	2	2700	9,8	0,95	70	5,3	0,58	3,6	35	0,00092	12,3	x	x	x
M90Sb	1,5	2	2750	9	0,98	75	5,2	0,74	3,7	40	0,00114	14,7	x	x	x
M90La	1,85	2,5	2780	10,7	0,99	76	6,35	0,65	3,5	50	0,00182	16,8	x	x	x
M90Lb	2,2	3	2740	12,7	0,99	76	6,67	0,7	3	60	0,00182	16,8	x	x	x
M100L	2,5	3,5	2850	14,7	0,99	73	8,4	0,7	4	80	0,0039	22	x	x	x
1500 min⁻¹ 4 poles 50Hz															
M56	0,09	0,12	1300	1	0,9	40	0,66	0,75	1,7	5	0,00012	3,3	x	x	x
M63a	0,11	0,15	1330	1,15	0,93	45	0,79	1	1,6	6	0,0002	4	x	x	x
M63b	0,18	0,25	1350	1,7	0,99	48	1,31	1	1,6	10	0,0003	4,7	x	x	x
M71a	0,25	0,35	1330	2	0,93	60	1,8	1	2,3	10	0,00064	6,5	x	x	x
M71b	0,37	0,5	1300	3,2	0,92	55	2,72	1	2,5	16	0,00086	7,7	x	x	x
M80a	0,55	0,75	1360	3,7	0,98	64	3,86	0,52	2,7	14	0,00142	8,9	x	x	x
M80b	0,75	1	1400	5,3	0,94	65	5,1	0,5	3,5	20	0,00184	10,4	x	x	x
M90S	1,1	1,5	1360	7	0,95	72	7,72	0,6	2,6	35	0,00242	13,3	x	x	x
M90La	1,5	2	1360	9,3	0,96	73	10,8	0,5	3	45	0,00247	16,2	x	x	x
M90Lb	1,85	2,5	1360	12,1	0,91	73	13	0,5	3,1	55	0,00268	17,8	x	x	x
M100La	1,85	2,5	1360	12,2	0,94	70	13	0,6	3	55	0,00403	21,4	x	x	x
M100Lb	2,2	3	1350	13	0,97	76	15,6	0,5	4	70	0,00506	23,9	x	x	x
1000 min⁻¹ 6 poles 50Hz															
M71	0,18	0,25	920	1,8	0,8	55	1,92	0,7	2,2	8	0,00065	7	x	x	x
M80a	0,25	0,35	940	2,5	0,8	55	2,54	0,6	2,7	10	0,00142	8,5	x	x	x
M80b	0,37	0,5	920	3,3	0,94	51	3,84	0,65	2,1	16	0,00186	10	x	x	x
M90S	0,55	0,75	915	4,25	0,88	64	5,74	0,5	2,3	20	0,0039	12,2	x	x	x
M90La	0,75	1	945	5,8	0,88	64	7,6	0,5	2,7	25	0,00296	14,5	x	x	x
M90Lb	1,1	1,5	880	8	0,95	63	11,94	0,5	2	40	0,00267	17	x	x	x
M100La	1,1	1,5	935	8,1	0,91	65	11,95	0,4	2,3	35	0,00343	20	x	x	x
M100Lb	1,5	2	930	10,6	0,96	64	15,4	0,5	2,9	50	0,00403	21,3	x	x	x

** Only FHC version

Dimensions B3 - B5



B3

- B6
- B7
- B8
- V5
- V6

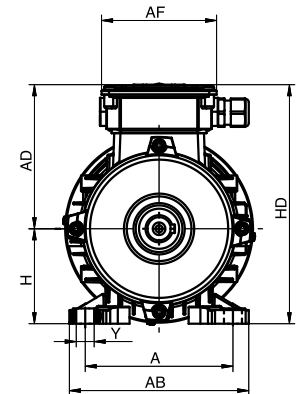
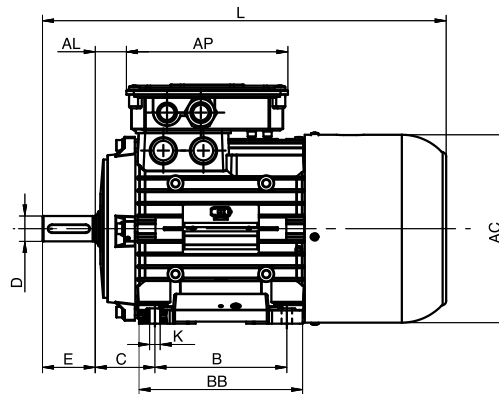

B5

- V1
- V3

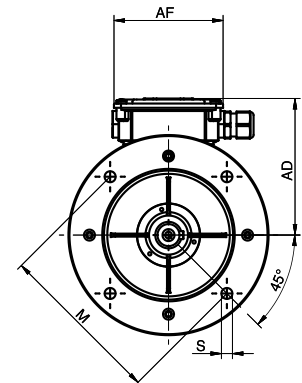
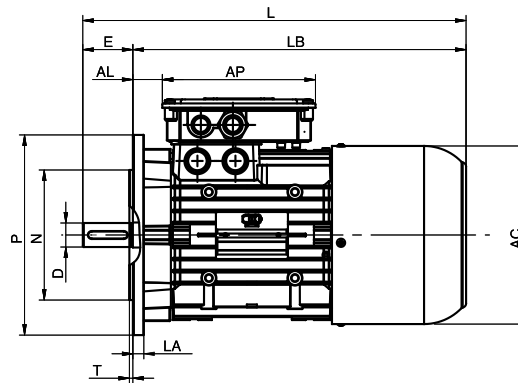

Dimensions in mm

Tolerances
(DIN 748-7160-7161-42948)

D	≤ 28 mm	j6
	38 - 50 mm	k6
N	≤ 230 mm	j6
	> 230 mm	h6
H	≤ 250 mm	+0 / -0,5 mm
	> 250 mm	+0 / -1 mm

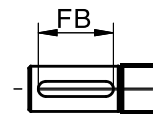
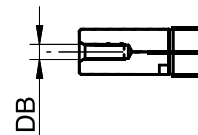
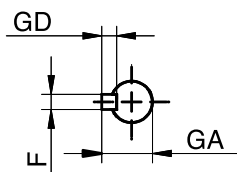

SIZE	B3														B5														
	A	AB	B	BB	C	D	E	H	HD	L	K	Y	AC	AD	AF	AP	AL	F	FB	GA	GD	DB	P	N	M	T	S	LA	LB
M56	90	109	71	91	36	9	20	56	168	211	6	11	115	112	93	131	13	3	15	10,2	3	M3	120	80	100	3	7	8	191
M63	100	120	80	106	40	11	23	63	176	256	7	12	123	113	93	131	19	4	15	12,5	4	M4	140	95	115	3	10	10	233
M71	112	136	90	108	45	14	30	71	196	286	8	12	147	125	93	131	24	5	20	16	5	M5	160	110	130	3	10	9	256
M80	125	160	100	125	50	19	40	80	213	332	9,5	17	165	133	109	152	23	6	30	21,5	6	M6	200	130	165	3,5	12	10,5	292
M90S	140	175	100	131	56	24	50	90	228	357	9,5	17	181	138	109	152	28	8	40	27	7	M8	200	130	165	3,5	12	10,5	307
M90L	140	175	125	156	56	24	50	90	228	382	9,5	17	181	138	109	152	28	8	40	27	7	M8	200	130	165	3,5	12	10,5	332
M100L	160	200	140	170	63	28	60	100	249	442	11	21	198	149	109	152	32	8	50	31	7	M10	250	180	215	4	14,5	14	382
M112M	190	225	140	177	70	28	60	112	285	447	11	21	222	173	132	205	35	8	50	31	7	M10	250	180	215	4	A14,5	14	387
M132S	216	260	140	181	89	38	80	132	321	534	11	21	264	189	134	208	44	10	70	41	8	M12	300	230	265	4	14,5	20	454
M132M	216	260	178	220	89	38	80	132	321	574	11	21	264	189	134	208	44	10	70	41	8	M12	300	230	265	4	14,5	20	494
M160M	254	318	210	260	108	42	110	160	403	770	13	23	317	243	186	171	52,5	12	90	45	8	M16	350	250	300	5	18,5	15	660
M160L	254	318	254	304	108	42	110	160	403	805	13	23	317	243	186	171	52,5	12	90	45	8	M16	350	250	300	5	18,5	15	695
M180M	279	345	241	291	121	48	110	180	440	870	13	38	352	260	185	171	54	14	90	51,5	9	M16	350	250	300	5	18,5	20	760
M180L	279	345	279	330	121	48	110	180	440	870	13	38	352	260	185	171	54	14	90	51,5	9	M16	350	250	300	5	18,5	20	760

All the charts include approximate values and dimensions. CEG Srl reserve the right to modify values and/or dimensions without notice.

Dimensions B14



B14

V18

V19

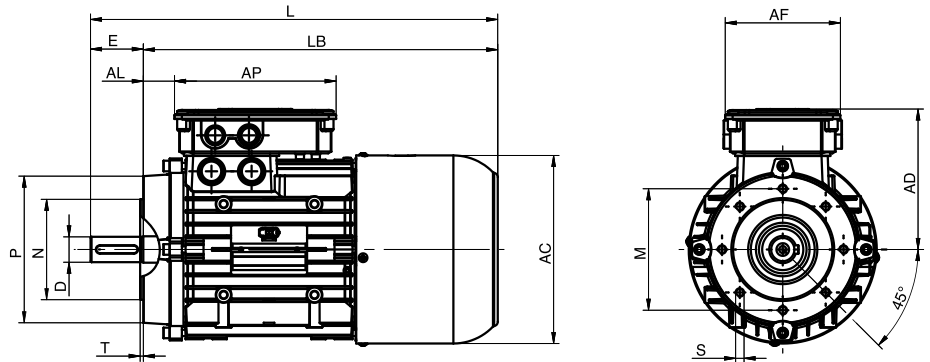

Dimensions in mm

Tolerances
(DIN 748-7160-7161-42948)

D	≤ 28 mm	j6
	38 - 50 mm	k6
	> 50 mm	m6
N	≤ 230 mm	j6
	> 230 mm	h6
H	≤ 250 mm	+0 / -0,5 mm
	> 250 mm	+0 / -1 mm

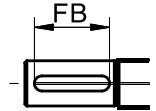
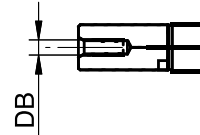
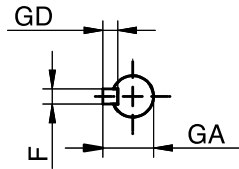

SIZE																					B14								
	A	AB	B	BB	C	D	E	H	HD	L	K	Y	AC	AD	AF	AP	AL	F	FB	GA	GD	DB	P	N	M	T	S	LB	LB
M56	90	109	71	91	36	9	20	56	168	211	6	11	115	112	93	131	13	3	15	10,2	3	M3	80	50	65	2,5	M5	191	191
M63	100	120	80	106	40	11	23	63	176	256	7	12	123	113	93	131	19	4	15	12,5	4	M4	90	60	75	2,5	M5	233	233
M71	112	136	90	108	45	14	30	71	196	286	8	12	147	125	93	131	24	5	20	16	5	M5	105	70	85	3	M6	256	256
M80	125	160	100	125	50	19	40	80	213	332	9,5	17	165	133	109	152	23	6	30	21,5	6	M6	120	80	100	3	M6	292	292
M90S	140	175	100	131	56	24	50	90	228	357	9,5	17	181	138	109	152	28	8	40	27	7	M8	140	95	115	3	M8	307	307
M90L	140	175	125	156	56	24	50	90	228	382	9,5	17	181	138	109	152	28	8	40	27	7	M8	140	95	115	3	M8	332	332
M100L	160	200	140	170	63	28	60	100	249	442	11	21	198	149	109	152	32	8	50	31	7	M10	160	110	130	3,5	M8	382	382
M112M	190	225	140	177	70	28	60	112	285	447	11	21	222	173	132	205	35	8	50	31	7	M10	160	110	130	3,5	M8	387	387
M132S	216	260	140	181	89	38	80	132	321	534	11	21	264	189	134	208	44	10	70	41	8	M12	200	130	165	4	M10	454	454
M132M	216	260	178	220	89	38	80	132	321	574	11	21	264	189	134	208	44	10	70	41	8	M12	200	130	165	4	M10	494	494
M160M	254	318	210	260	108	42	110	160	403	770	13	23	317	243	186	171	52,5	12	90	45	8	M16	250	180	215	5	M10	660	660
M160L	254	318	254	304	108	42	110	160	403	805	13	23	317	243	186	171	52,5	12	90	45	8	M16	250	180	215	5	M10	695	695
M180M	279	345	241	291	121	48	110	180	440	870	13	38	352	260	185	171	54	14	90	51,5	9	M16							
M180L	279	345	279	330	121	48	110	180	440	870	13	38	352	260	185	171	54	14	90	51,5	9	M16							

All the charts include approximate values and dimensions. CEG Srl reserve the right to modify values and/or dimensions without notice.



ORANGE1
HOLDING

CEG S.r.l.

Via A. Grandi, 23
47030 San Mauro Pascoli, FC (IT)
T. +39 0541 815611
F. +39 0541 815684

info@orange1.eu
www.orange1.eu

follow us   

