



aerospace
 climate control
 electromechanical
 filtration
 fluid & gas handling
 hydraulics
 pneumatics
 process control
 sealing & shielding



Fluid Control Valves Favorite Selection



PRIMERA
 Technological **PRODUCT AND SERVICE** Solutions
Parker Tecnologias de Movimento,
 DISTRIBUIDOR Controle e Refrigeração
 Your local authorized Parker distributor
ENGINEERING YOUR SUCCESS

The Fluid Control Division in Europe (FCDE) is a division of Parker Hannifin, the global leader in motion and control technologies.

Our European headquarters are located in Geneva, this is also where our R&D, Marketing, Application Support and Product Management functions are located.

History

Parker FCDE has been a leading player in the manufacturing and development of solenoid valve technologies for over 60 years, with continuous research and development bringing innovative solutions to the marketplace, for example leading the way in the utilisation of synthetic ruby for critical water applications or the unsurpassed reliability and precision of our pressure regulators.

The expertise accumulated and developed through the years is evident in the superior quality of FCDE solutions.

Fast Delivery

Most products listed in this catalogue are showing the fast delivery sign as you can see below.



These products are stocked items and will ensure the shortest delivery time.

Quality Standards



- ISO 9001
- ISO 14001

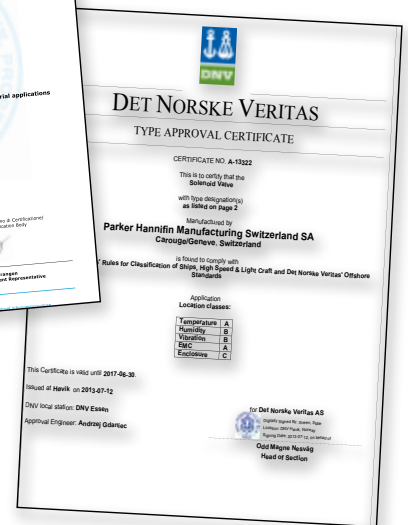

Certifications and approvals

Our products have been approved and are compliant with the relevant market requirements including:

- CE
- UL
- AGA
- RoHS
- IECEx
- TR CU
- TUV
- NSF
- ATEX
- Kosha
- VDE
- Reach
- CSA
- DIN
- IMQ



TABLE OF CONTENT

HOW TO SELECT A VALVE004

2 WAY VALVES

All Fluids and Air.....007

Water.....041

Hot Water & Steam.....053

3 & 5 WAY VALVES

Air.....059

All Fluids & Air.....071

SPARE PARTS

Repair Kits, Coils & Plugs.....087

MORE PRODUCTS

More Voltages.....110

Other Products.....120

TECHNICAL INFORMATION122

INDEX FOR VALVES126



HOW TO SELECT A VALVE

Once you are in the selected family **1** and application **2**.

The summary table is designed to help you navigate to the products matching your criteria.

First decide the actuation **3**, then move across the table selecting your body material **4**, function **5** and technical requirements **6**.

After you have found products fitting within your specification, please go to the corresponding page number in column **7**, here you will find a selection of products matching your criteria.

1

SELECT PRODUCT FAMILY

2

SELECT APPLICATION

3

SELECT ACTUATION

4

SELECT BODY

5

SELECT FUNCTION

6

SELECT TECHNICAL DATA

7

SELECT CORRESPONDING PAGE

Please find below the pictograms you will find in the catalogue to help you identify the specifications of each valves

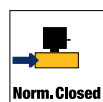

Valve is closed when de-energized



Valve capable of high pressure

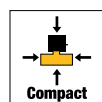

Compact size valve

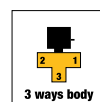

3 way in the valve body

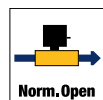

Valve is open when de-energized



Valve with high performances



Fast delivery

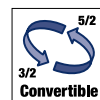

Valve with 3/2 - 5/2 conversion plate



Allows manual control of the valve



Valve with high flow factor KV



Anti water hammer valve

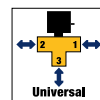

Valve can be used as NC/NO, bypass and mixer applications



Valve with large orifice



Valve easy to maintain and service

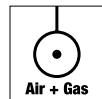

Valve compatible with air and neutral gases only



Valve for slurry solutions, high pressures, high temperatures



1 2/2

2 VALVES FOR ALL FLUIDS AND AIR



The Parker 2 way valves (1 way for inlet and 1 way for outlet) for all fluids, including air, offer large possibilities to control many kinds of fluids with different sealing and flow capabilities. According to the installation and requirements, a wide selection of robust valves is proposed to fulfill the most demanding needs. Typical applications are:

- Shut off valves
- Filling
- Dosing
- Air handling
- Mixing

These applications can be found in many markets where reliability and performances are key factors like in industries, water treatment, transportation, medical, process, etc...

2 WAY VALVES

All Fluids & Air

Actuation	Body	Function	Specification	Port Size	Orifice (mm)	MOPB (bar)	Page
Direct Operated (No minimum pressure required)	Brass/ Pipe Mounting	Normally Closed	-	1/8" to 1/4"	2 to 6	15	8
		High Performance	High Performance	1/4" to 1/2"	1.2 to 11	80	10
	316L Stainless SL/ Pipe Mounting	High Performance / Manual override	High Performance	1/8"	3 to 4	10	16
		Normally Open	High Performance	1/4"	1.5 to 2.5	30	17
Pilot Operated (Minimum pressure required)	Brass/ Pipe Mounting	Normally Closed	-	1/8" to 1/2"	1.5 to 5	20	18
		Normally Open	-	1/4"	3	6	19
	316L Stainless SL/ Pipe Mounting	Normally Closed	Compact / High flow	1/4" to 1/2"	11	10	20
		Normally Open	Easy Maintenance	1/4" to 1"	12 to 18	10	28
Magnalift (No minimum pressure - High flow)	Brass/ Pipe Mounting	For Air / Neutral Gases	For Air / Neutral Gases	1"	13 to 25	16	16
		High Flow / High Pressure	High Flow / High Pressure	1/2"	8 to 15	40	30
	316L Stainless SL/ Pipe Mounting	Easy Maintenance	Easy Maintenance	1/2" to 3/4"	12 to 18	12	30
		High Flow / High Pressure	High Performance	1/2"	15	15	31
Air Operated	Brass/ Pipe Mounting	High Performance	High Performance	1/2"	15	15	31
		Normally Closed	-	3/8" to 1"	13 to 25	5	32
	316L Stainless SL/ Pipe Mounting	High Performance	High Performance	3/8" to 1"	15 to 25	16	33
		Normally Closed	-	3/8" to 1"	15 to 24	10	35
316L S.Steel Body / 304 S.Steel Actuator/ Pipe Mounting	Normally Closed	Angle Seat Valve - Air operated	Angle Seat Valve - Air operated	3/8" to 1-1/4"	13 to 31	16	36
	Normally Open	Angle Seat Valve - Air operated	Angle Seat Valve - Air operated	3/8" to 1-1/4"	13 to 31	16	38
	Normally Closed	Angle Seat Valve - Air operated	Angle Seat Valve - Air operated	1/2" to 1"	13 to 24	16	39





2/2

VALVES FOR ALL FLUIDS AND AIR



The Parker 2 way valves (1 way for inlet and 1 way for outlet) for all fluids, including air, offer large possibilities to control many kinds of fluids with different sealing and flow capabilities. According to the installation and requirements, a wide selection of robust valves is proposed to fulfill the most demanding needs.

Typical applications are:

- Shut off valves
- Filling
- Dosing
- Air handling
- Mixing

These applications can be found in many markets where reliability and performances are key factors like in industries, water treatment, transportation, medical, process, etc...

Actuation	Body	Function	Specification	Port Size	Orifice (mm)	MOPD (bar)	Page	
Direct Operated (No minimum pressure required)	Brass/ Pipe Mounting	Normally Closed	-	1/8" to 1/4"	2 to 6	15	8	
			High Performance	1/4" to 1/2"	1.2 to 11	80	10	
			High Performance / Manual override	1/4"	3 to 4	10	16	
	316L Stainless St./ Pipe Mounting	Normally Open	High Performance	1/4"	1.5 to 2.5	30	17	
			Normally Closed	-	1/8" to 1/2"	1.5 to 5	20	18
			Normally Open	-	1/4"	3	6	19
Pilot Operated (Minimum pressure required)	Brass/ Pipe Mounting	Normally Closed	Compact / High flow	1/4" to 1/2"	11	10	20	
			Easy Maintenance	1/4" to 1"	12 to 18	10	22	
			For Air / Neutral Gases	3/8" to 1"	13 to 25	16	26	
			High Flow / High Pressure	1/4" to 1/2"	8 to 15	40	27	
		Normally Open	Easy Maintenance	1/4" to 3/4"	12 to 18	12	29	
			High Flow / High Pressure	1/2"	15	40	30	
			High Performance	1/2"	15	15	31	
Magnalift (No minimum pressure - High flow)	Brass/ Pipe Mounting	Normally Closed	-	3/8" to 1"	13 to 25	5	32	
			High Performance	3/8" to 1"	15 to 25	16	33	
	316L Stainless St./ Pipe Mounting	Normally Closed	-	3/8" to 1"	15 to 24	10	35	
Air Operated	316L S.Steel Body / 304 S.Steel Actuator/ Pipe Mounting	Normally Closed	Angle Seat Valve - Air operated	3/8" to 1-1/4"	13 to 31	16	36	
		Normally Open	Angle Seat Valve - Air operated	3/8" to 1-1/4"	13 to 31	16	38	
	316L S.Steel Body / Aluminium Actuator/ Pipe Mounting	Normally Closed	Angle Seat Valve - Air operated	1/2" to 1"	13 to 24	16	39	

2/2

VALVES FOR ALL FLUIDS AND AIR DIRECT OPERATED



BRASS PIPE MOUNTING NORMALLY CLOSED

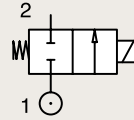

Port size	Orifice Ø	Flow factors			Seat Seal	Atex Zone	Operating Pressure Differential		Fluid Temp.		Power	Voltage	Solenoid Valve Order Number
		Kv l/min	KV m³/h	Qn l/min			Min bar	Max bar	Min °C	Max °C			
1/8"	2	1.5	0.09	-	FKM	-	0	15	-10	140	4.5	230V/50-60Hz	550193DIS ₁
							0	7	-10	140	5	24 Vdc	550058DIS ₁
	0	10	-10				140	4.5	230V/50-60Hz	550059DIS ₁			
	0	4	-10				140	5	24 Vdc	550194DIS ₁			
	2.5	2.2	0.13				0	10	-10	140	9	230V/50-60Hz	550094DIS ₂
							0	5	-10	140	12	24 Vdc	550093DIS ₂
	3	3.3	0.20				0	7	-10	140	9	230V/50-60Hz	550096DIS ₂
							0	4.5	0.27	0	2	-10	140

Notes:

1. Drawing number 1
2. Drawing number 2

Fast Delivery

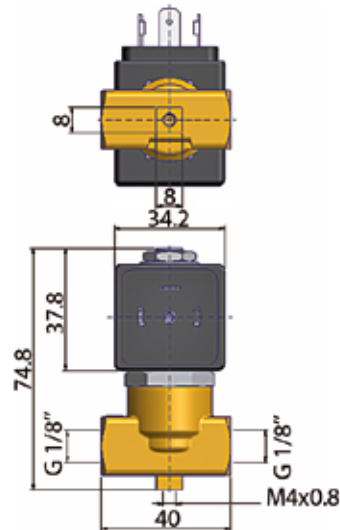
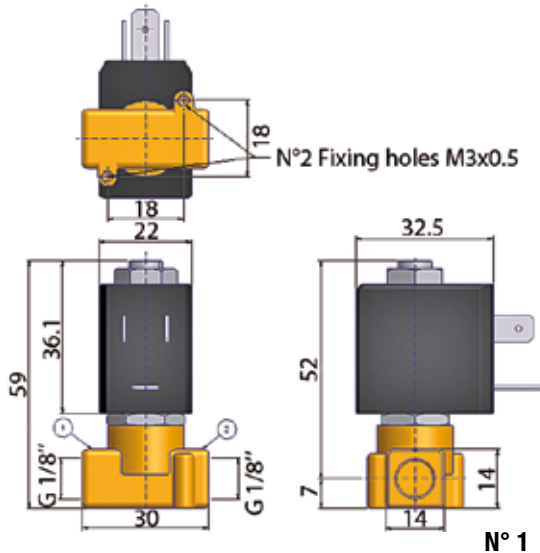

2/2

VALVES FOR ALL FLUIDS AND AIR DIRECT OPERATED

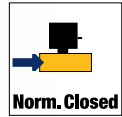

All Fluids & Air

BRASS
PIPE MOUNTING
NORMALLY CLOSED

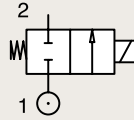

Port size	Orifice Ø	Flow factors			Seat Seal	Atex Zone	Operating Pressure Differential		Fluid Temp.		Power	Voltage	Solenoid Valve Order Number
		Kv l/min	KV m³/h	Qn l/min			Min bar	Max bar	Min °C	Max °C			
1/4"	2.5	2.3	0.14	-	FKM	-	0	10	-10	140	4.5	230V/50-60Hz	550061DIS ₁
		0	4				-10	140	5	24 Vdc	550060DIS ₁		
		0	10				-10	140	9	230V/50-60Hz	550098DIS ₂		
	3	3.3	0.20				0	10	-10	140	12	24 Vdc	550097DIS ₂
		0	7				-10	140	9	230V/50-60Hz	550100DIS ₂		
		0	2				-10	140	12	24 Vdc	550099DIS ₂		
		0	6				-10	140	14	230V/50-60Hz	550196DIS ₂		
		0	2.5				-10	140	16	24 Vdc	550092DIS ₂		
		0	6				-10	140	14	230V/50-60Hz	550091DIS ₂		
		0	1				-10	140	16	24 Vdc	550195DIS ₂		

Notes:

- 1. Drawing number 1
- 2. Drawing number 2

Fast Delivery

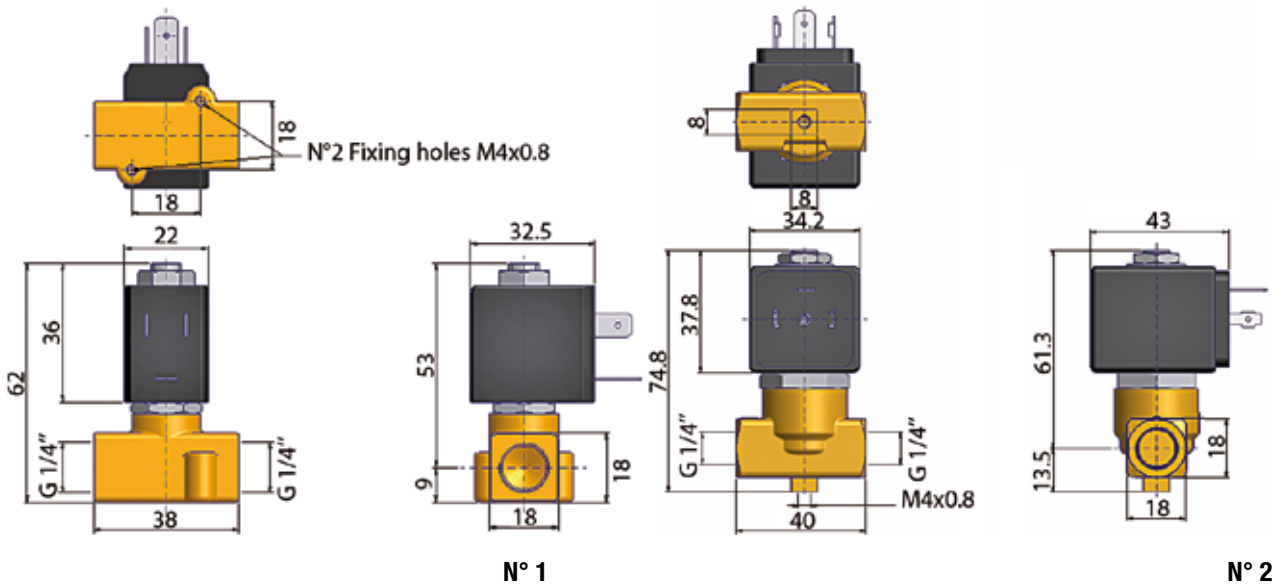

2/2

VALVES FOR ALL FLUIDS AND AIR DIRECT OPERATED

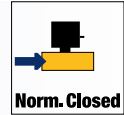

BRASS
PIPE MOUNTING

NORMALLY CLOSED

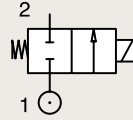

Port size	Orifice Ø	Flow factors			Seat Seal	Atex Zone	Operating Pressure Differential		Fluid Temp.		Power	Voltage	Solenoid Valve Order Number
		Kv l/min	KV m³/h	Qn l/min			Min bar	Max bar	Min °C	Max °C			
1/4"	1.2	0.85	0.05	50	Ruby	-	0	80	-30	100	8	220-230V/50Hz	E121K65-2995-4818653D
						-	0	36	-30	100	9	24 Vdc	E121K65-2995-481865C2
						2-22	0	80	-30	65	8	220-230V/50Hz	E121K65-2995-4958703D
						2-22	0	36	-30	65	9	24 Vdc	E121K65-2995-495870C2
						1-21	0	80	-30	80	8	230V/50Hz	E121K65-495905F4
						1-21	0	36	-30	80	8	24 Vdc	E121K65-495905C2
	1.5	1.5	0.09	80	PCTFE	-	0	60	-30	75	8	220-230V/50Hz	E121K04-2995-4818653D
						-	0	25	-30	75	9	24 Vdc	E121K04-2995-481865C2
						2-22	0	60	-30	65	8	220-230V/50Hz	E121K04-2995-4958703D
						2-22	0	25	-30	65	9	24 Vdc	E121K04-2995-495870C2
						1-21	0	60	-30	75	8	230V/50Hz	E121K04-495905F4
						1-21	0	25	-30	75	8	24 Vdc	E121K04-495905C2

Fast Delivery

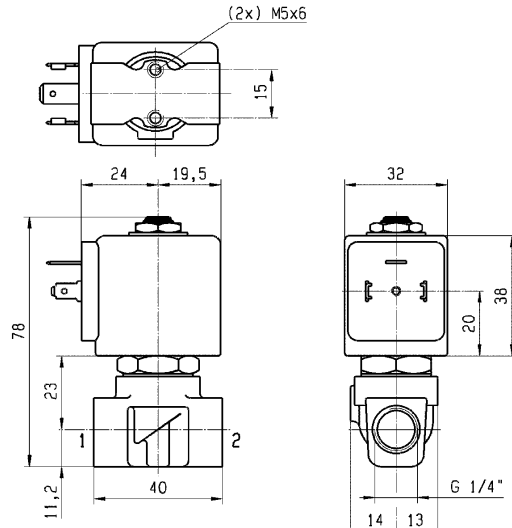

2/2

VALVES FOR ALL FLUIDS AND AIR DIRECT OPERATED



All Fluids & Air

BRASS PIPE MOUNTING NORMALLY CLOSED

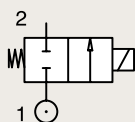

Port size	Orifice Ø	Flow factors			Seat Seal	Atex Zone	Operating Pressure Differential		Fluid Temp.		Power	Voltage	Solenoid Valve Order Number		
		Kv l/min	KV m³/h	Qn l/min			Min bar	Max bar	Min °C	Max °C				W	
1/4"	2.5	3.5	0.21	220	FKM	-	0	14	-10	100	8	220-230V/50Hz	121K0706-2995-4818653D		
							0	7	-10	100	9	24 Vdc	121K0706-2995-481865C2		
							0	12	-10	120	14	24 Vdc	121K0706-2995-492425C2		
							0	14	-10	65	8	220-230V/50Hz	121K0706-2995-4958703D		
							0	7	-10	65	9	24 Vdc	121K0706-2995-495870C2		
							0	12	-10	120	14	24 Vdc	121K0706-2995-492425C2		
						1-21	0	14	-10	80	8	230V/50Hz	121K0706-495905F4		
							0	7	-10	80	8	24 Vdc	121K0706-495905C2		
							Ruby	-	0	28	-30	100	8	220-230V/50Hz	E121K63-2995-4818653D
									0	10	-30	100	9	24 Vdc	E121K63-2995-481865C2
								2-22	0	28	-30	65	8	220-230V/50Hz	E121K63-2995-4958703D
									0	10	-30	65	9	24 Vdc	E121K63-2995-495870C2
0	28	-30	80	8	230V/50Hz	E121K63-495905F4									
0	10	-30	80	8	24 Vdc	E121K63-495905C2									

Fast Delivery

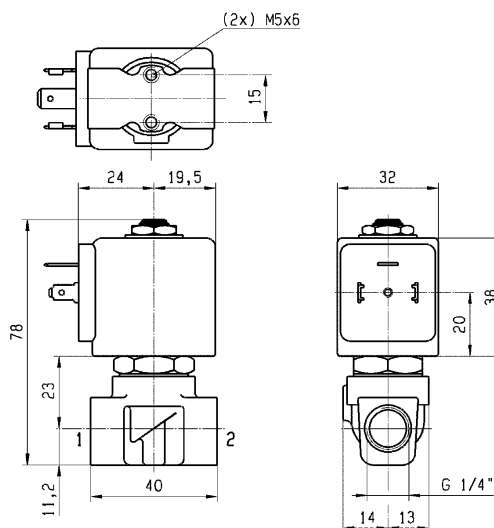

2 WAY VALVES

2/2

VALVES FOR ALL FLUIDS AND AIR DIRECT OPERATED

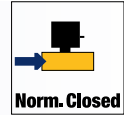

BRASS
PIPE MOUNTING

NORMALLY CLOSED

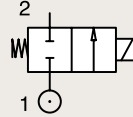

Port size	Orifice Ø	Flow factors			Seat Seal	Atex Zone	Operating Pressure Differential		Fluid Temp.		Power	Voltage	Solenoid Valve Order Number		
		Kv l/min	KV m³/h	Qn l/min			Min bar	Max bar	Min °C	Max °C				W	
1/4"	3	4.5	0.27	320	PCTFE	-	0	20	-30	75	8	220-230V/50Hz	E121K03-2995-4818653D	ATEX	
							0	7	-30	75	9	24 Vdc	E121K03-2995-481865C2		
							2-22	0	20	-30	65	8	220-230V/50Hz		E121K03-2995-4958703D
								0	7	-30	65	9	24 Vdc		E121K03-2995-495870C2
							1-21	0	20	-30	75	8	230V/50Hz		E121K03-495905F4
								0	7	-30	75	8	24 Vdc		E121K03-495905C2
						FKM	-	0	10	-10	100	8	220-230V/50Hz		E121K0302-2995-4818653D
								0	7	-10	100	9	24 Vdc		E121K0302-2995-481865C2
							2-22	0	10	-10	65	8	220-230V/50Hz		E121K0302-2995-4958703D
								0	7	-10	65	9	24 Vdc		E121K0302-2995-495870C2
							1-21	0	10	-10	80	8	230V/50Hz		E121K0302-495905F4
								0	7	-10	80	8	24 Vdc		E121K0302-495905C2
					Ruby	-	0	20	-30	100	8	220-230V/50Hz	E121K64-2995-4818653D		
							0	7	-30	100	9	24 Vdc	E121K64-2995-481865C2		
						2-22	0	20	-30	65	8	220-230V/50Hz	E121K64-2995-4958703D		
							0	7	-30	65	9	24 Vdc	E121K64-2995-495870C2		
						1-21	0	20	-30	80	8	230V/50Hz	E121K64-495905F4		
							0	7	-30	80	8	24 Vdc	E121K64-495905C2		

Fast Delivery

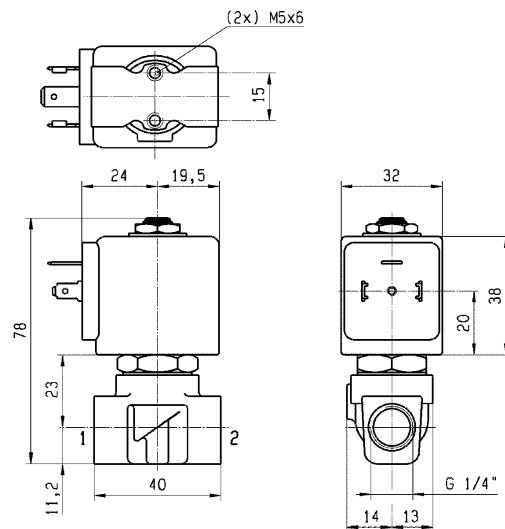

2/2

VALVES FOR ALL FLUIDS AND AIR DIRECT OPERATED

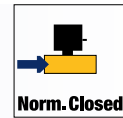

All Fluids & Air

2 WAY VALVES

BRASS

PIPE MOUNTING

NORMALLY CLOSED

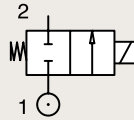

Port size	Orifice Ø	Flow factors			Seat Seal	Atex Zone	Operating Pressure Differential		Fluid Temp.		Power	Voltage	Solenoid Valve Order Number	
		Kv l/min	KV m³/h	Qn l/min			Min bar	Max bar	Min °C	Max °C				W
1/4"	4	7.5	0.45	480	FKM	-	0	10	-10	100	8	220-230V/50Hz	121K02-2995-4818653D	
							0	10	-10	120	14	230V/50Hz	121K02-2995-492425F4	
							0	4	-10	100	9	24 Vdc	121K02-2995-481865C2	
							0	10	-10	120	14	24 Vdc	121K02-2995-492425C2	
							2-22	0	10	-10	65	8	220-230V/50Hz	121K02-2995-4958703D
							2-22	0	4	-10	65	9	24 Vdc	121K02-2995-495870C2
	1-21	0	10	-10		80	8	230V/50Hz	121K02-495905F4					
	1-21	0	4	-10		80	8	24 Vdc	121K02-495905C2					
	5	11	0.66	750		-	0	7	-10	100	8	220-230V/50Hz	121K01-2995-4818653D	
							0	2	-10	100	9	24 Vdc	121K01-2995-481865C2	
							0	5	-10	120	14	24 Vdc	121K01-2995-492425C2	
							2-22	0	7	-10	65	8	220-230V/50Hz	121K01-2995-4958703D
2-22					0		2	-10	65	9	24 Vdc	121K01-2995-495870C2		
1-21					0		7	-10	80	8	230V/50Hz	121K01-495905F4		
1-21	0	2	-10	80	8	24 Vdc	121K01-495905C2							

Fast Delivery

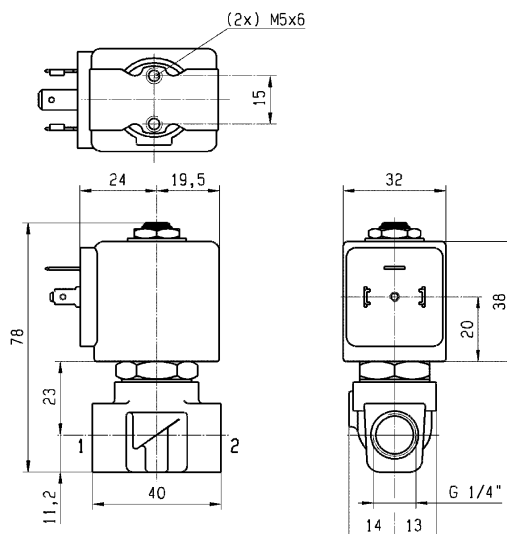

2/2

VALVES FOR ALL FLUIDS AND AIR DIRECT OPERATED

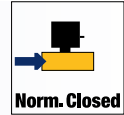

BRASS PIPE MOUNTING NORMALLY CLOSED

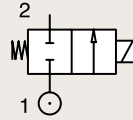

Port size	Orifice Ø	Flow factors			Seat Seal	Atex Zone	Operating Pressure Differential		Fluid Temp.		Power	Voltage	Solenoid Valve Order Number	
		Kv l/min	KV m³/h	Qn l/min			Min bar	Max bar	Min °C	Max °C				W
3/8"	5	11	0.66	750	FKM	-	0	7	-10	100	8	220-230V/50Hz	121K3106-2995-4818653D	
							0	2	-10	100	9	24 Vdc	121K3106-2995-481865C2	
							0	5	-10	120	14	24 Vdc	121K3106-2995-492425C2	
							2-22	0	7	-10	65	8	220-230V/50Hz	121K3106-2995-4958703D
							2-22	0	2	-10	65	9	24 Vdc	121K3106-2995-495870C2
							1-21	0	7	-10	80	8	230V/50Hz	121K3106-495905F4
	1-21	0	2	-10		80	8	24 Vdc	121K3106-495905C2					
	6	12	0.72	1100		-	0	5	-10	120	8	220-230V/50Hz	121K3306-2995-4818653D	
							0	5	-10	120	14	230V/50Hz	121K3306-2995-492425F4	
							0	1.1	-10	120	9	24 Vdc	121K3306-2995-481865C2	
							0	3	-10	120	14	24 Vdc	121K3306-2995-492425C2	
							2-22	0	5	-10	65	8	220-230V/50Hz	121K3306-2995-4958703D
2-22					0		1.1	-10	65	9	24 Vdc	121K3306-2995-495870C2		
1-21	0	5	-10	80	8	230V/50Hz	121K3306-495905F4							
								0	1.1	-10	80	8	24 Vdc	121K3306-495905C2

Fast Delivery

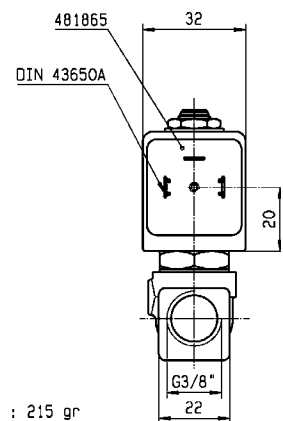
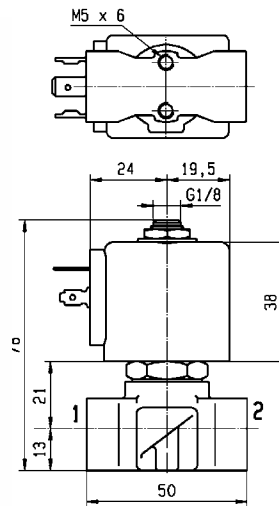

WEIGHT : 215 gr



2/2

VALVES FOR ALL FLUIDS AND AIR DIRECT OPERATED

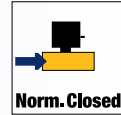

All Fluids & Air

2 WAY VALVES

BRASS PIPE MOUNTING NORMALLY CLOSED

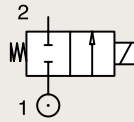

Port size	Orifice Ø	Flow factors			Seat Seal	Atex Zone	Operating Pressure Differential		Fluid Temp.		Power	Voltage	Solenoid Valve Order Number	
		Kv l/min	KV m³/h	Qn l/min			Min bar	Max bar	Min °C	Max °C				W
1/2"	8.5	25	1.50	1600	FKM	-	0	1.1	-10	100	8	220-230V/50Hz	E121K46-2995-4818653D	
							0	4	-10	120	14	230V/50Hz	E121K46-2995-492425F4	
							0	0.5	-10	100	9	24 Vdc	E121K46-2995-481865C2	
							0	1.2	-10	120	14	24 Vdc	E121K46-2995-492425C2	
							2-22	0	1.1	-10	65	8	220-230V/50Hz	E121K46-2995-4958703D
							2-22	0	0.5	-10	65	9	24 Vdc	E121K46-2995-495870C2
	11	36	2.16	2500		1-21	0	1.1	-10	80	8	230V/50Hz	E121K46-495905F4	
							0	0.5	-10	80	8	24 Vdc	E121K46-495905C2	
							-	0	0.7	-10	100	8	220-230V/50Hz	E121K45-2995-4818653D
							-	0	0.3	-10	100	9	24 Vdc	E121K45-2995-481865C2
							2-22	0	2.5	-10	65	8	220-230V/50Hz	E121K45-2995-4958703D
							2-22	0	0.7	-10	65	9	24 Vdc	E121K45-2995-495870C2
1-21	0	0.7	-10	80	8	230V/50Hz	E121K45-495905F4							
	0	0.3	-10	80	8	24 Vdc	E121K45-495905C2							

Fast Delivery

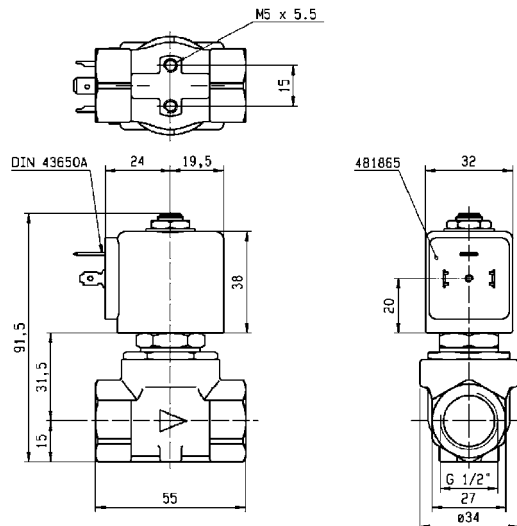

2/2

VALVES FOR ALL FLUIDS AND AIR DIRECT OPERATED



BRASS
PIPE MOUNTING

NORMALLY CLOSED

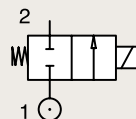

Port size	Orifice Ø	Flow factors			Seat Seal	Atex Zone	Operating Pressure Differential		Fluid Temp.		Power	Voltage	Solenoid Valve Order Number	
		Kv l/min	KV m³/h	Qn l/min			Min bar	Max bar	Min °C	Max °C				W
1/4"	3	4.5	0.27	320	FKM	-	0	10	-10	100	8	220-230V/50Hz	E121K0352-2995-4818653D	
							0	7	-10	100	9	24 Vdc	E121K0352-2995-481865C2	
							2-22	0	10	-10	65	8	220-230V/50Hz	E121K0352-2995-4958703D
							0	7	-10	65	9	24 Vdc	E121K0352-2995-495870C2	
							1-21	0	10	-10	80	8	230V/50Hz	E121K0352-495905F4
							0	7	-10	80	8	24 Vdc	E121K0352-495905C2	
	4	7.5	0.45	480		-	0	10	-10	100	8	220-230V/50Hz	121K0250-2995-4818653D	
							0	4	-10	100	9	24 Vdc	121K0250-2995-481865C2	
							2-22	0	10	-10	65	8	220-230V/50Hz	121K0250-2995-4958703D
							0	4	-10	65	9	24 Vdc	121K0250-2995-495870C2	
							1-21	0	10	-10	80	8	230V/50Hz	121K0250-495905F4
							0	4	-10	80	8	24 Vdc	121K0250-495905C2	

Fast Delivery

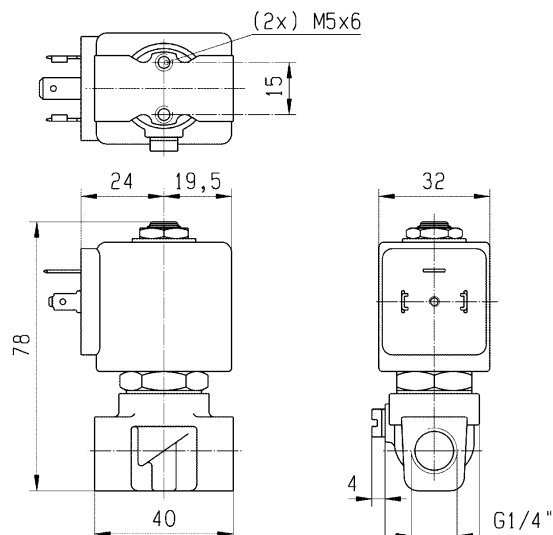

2/2

VALVES FOR ALL FLUIDS AND AIR DIRECT OPERATED

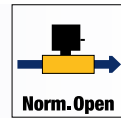

All Fluids & Air

2 WAY VALVES

**BRASS
PIPE MOUNTING
NORMALLY OPEN**

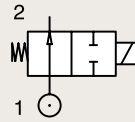

Port size	Orifice Ø	Flow factors			Seat Seal	Atex Zone	Operating Pressure Differential		Fluid Temp.		Power	Voltage	Solenoid Valve Order Number	
		Kv l/min	KV m³/h	Qn l/min			Min bar	Max bar	Min °C	Max °C				W
1/4"	1.5	1.5	0.09	80	PCTFE	-	0	30	-10	100	8	220-230V/50Hz	122K84-2995-4818653D	
							0	30	-10	100	9	24 Vdc	122K84-2995-481865C2	
							2-22	0	30	-10	65	8	220-230V/50Hz	122K84-2995-4958703D
								0	30	-10	65	9	24 Vdc	122K84-2995-495870C2
							1-21	0	30	-10	80	8	230V/50Hz	122K84-495905F4
								0	30	-10	80	8	24 Vdc	122K84-495905C2
						-	0	12	-30	75	8	220-230V/50Hz	122K83-2995-4818653D	
							0	12	-30	75	9	24 Vdc	122K83-2995-481865C2	
							2-22	0	12	-30	65	8	220-230V/50Hz	122K83-2995-4958703D
								0	12	-30	65	9	24 Vdc	122K83-2995-495870C2
							1-21	0	12	-30	75	8	230V/50Hz	122K83-495905F4
								0	12	-30	75	8	24 Vdc	122K83-495905C2
	2.5	3	0.18	180	FKM	-	0	12	-10	100	8	220-230V/50Hz	122K8306-2995-4818653D	
							0	12	-10	100	9	24 Vdc	122K8306-2995-481865C2	
							2-22	0	12	-10	65	8	220-230V/50Hz	122K8306-2995-4958703D
								0	12	-10	65	9	24 Vdc	122K8306-2995-495870C2
							1-21	0	12	-10	80	8	230V/50Hz	122K8306-495905F4
								0	12	-10	80	8	24 Vdc	122K8306-495905C2

Fast Delivery

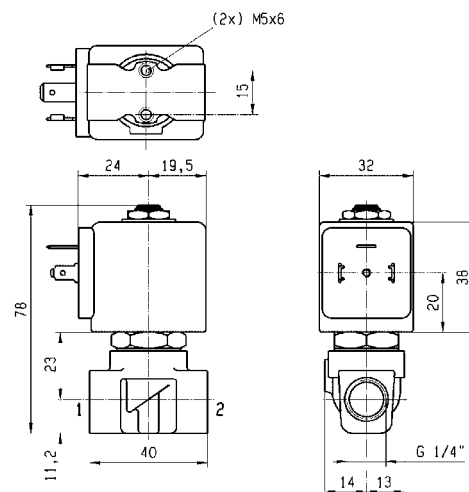

2/2

VALVES FOR ALL FLUIDS AND AIR DIRECT OPERATED



316L STAINLESS ST.
PIPE MOUNTING

NORMALLY CLOSED

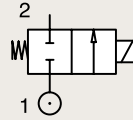

Port size	Orifice Ø	Flow factors			Seat Seal	Atex Zone	Operating Pressure Differential		Fluid Temp.		Power	Voltage	Solenoid Valve Order Number
		Kv l/min	KV m³/h	Qn l/min			Min bar	Max bar	Min °C	Max °C			
1/8"	1.5	1	0.06	-	FKM	-	0	20	-10	140	4	220-230V/50Hz	550001DIS ₁
							0	10	-10	140	5	24 Vdc	550000DIS ₁
							0	20	-10	140	4	220-230V/50Hz	550003DIS ₁
1/4"	2.5	2.3	0.14	-	FKM	-	0	10	-10	140	5	24 Vdc	550002DIS ₁
							0	10	-10	140	4	220-230V/50Hz	550005DIS ₁
							0	4	-10	140	5	24 Vdc	550004DIS ₁
3/8"	3	4.5	0.27	-	FKM	-	0	10	-10	140	11	220-240/50-60	550007DIS ₂
							0	11	-10	140	12	24 Vdc	550006DIS ₂
							0	4	-10	140	11	220-240/50-60	550009DIS ₂
1/2"	5	8	0.48	-	FKM	-	0	4	-10	140	12	24 Vdc	550008DIS ₂
							0	4	-10	140	11	220-240/50-60	550011DIS ₂
1/2"	5	8	0.48	-	FKM	-	0	4	-10	140	11	220-240/50-60	550010DIS ₂
							0	4	-10	140	12	24 Vdc	550010DIS ₂

Notes:

- 1. Drawing number 1
- 2. Drawing number 2

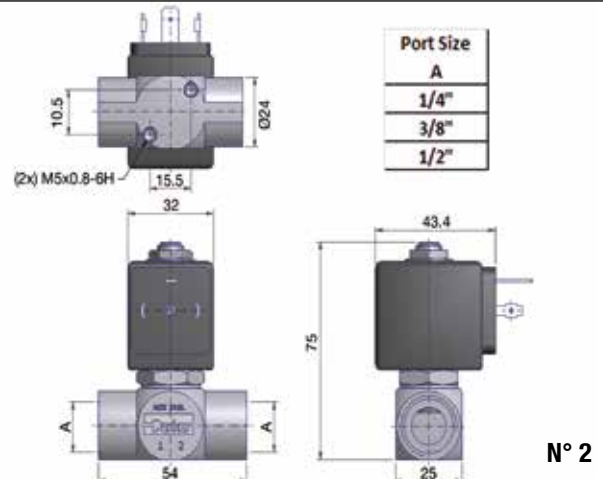
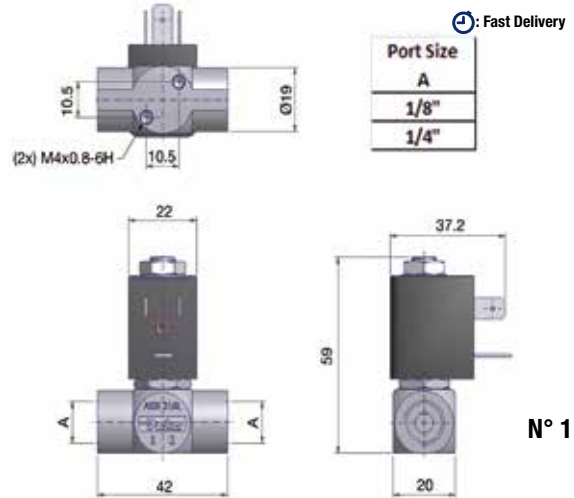

2/2

VALVES FOR ALL FLUIDS AND AIR DIRECT OPERATED

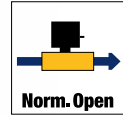

All Fluids & Air

316L STAINLESS ST.
PIPE MOUNTING

NORMALLY OPEN

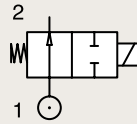

Port size	Orifice Ø	Flow factors			Seat Seal	Atex Zone	Operating Pressure Differential		Fluid Temp.		Power	Voltage	Solenoid Valve Order Number
		Kv l/min	KV m³/h	Qn l/min			Min bar	Max bar	Min °C	Max °C			
BSP	mm												
1/4"	3	4.5	0.27	-	FKM	-	0	6	-10	140	8	220-230V/50Hz	550013DIS
							0	6	-10	140	9	24 Vdc	550012DIS

Fast Delivery

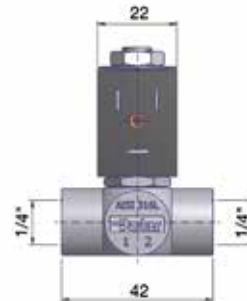
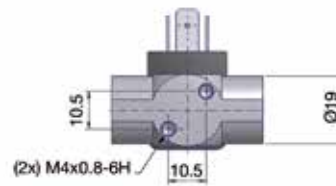
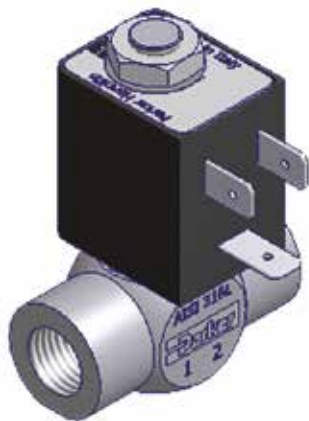

2 WAY VALVES

2/2

VALVES FOR ALL FLUIDS AND AIR PILOT OPERATED

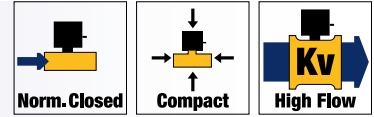

BRASS
PIPE MOUNTING

NORMALLY CLOSED

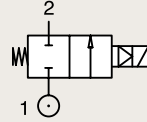

Port size	Orifice Ø	Flow factors			Seat Seal	Atex Zone	Operating Pressure Differential		Fluid Temp.		Power	Voltage	Solenoid Valve Order Number						
		Kv l/min	KV m³/h	Qn l/min			Min bar	Max bar	Min °C	Max °C				W					
1/4"	11	28	1.68	1800	NBR	-	0.2	10	-10	100	8	220-230V/50Hz	E321K10-2995-4818653D						
							0.2	3	-10	100	9	24 Vdc	E321K10-2995-481865C2						
							2-22	0.2	10	-10	65	8	220-230V/50Hz	E321K10-2995-4958703D					
							0.2	3	-10	65	9	24 Vdc	E321K10-2995-495870C2						
							1-21	0.2	10	-10	80	8	230V/50Hz	E321K10-495905F4					
							0.2	3	-10	80	8	24 Vdc	E321K10-495905C2						
							3/8"	36	2.16	2500	NBR	-	0.2	10	-10	100	8	220-230V/50Hz	E321K13-2995-4818653D
													0.2	3	-10	100	9	24 Vdc	E321K13-2995-481865C2
2-22	0.2	10	-10	65	8	220-230V/50Hz							E321K13-2995-4958703D						
0.2	3	-10	65	9	24 Vdc	E321K13-2995-495870C2													
1-21	0.2	10	-10	80	8	230V/50Hz							E321K13-495905F4						
0.2	4	-10	80	8	24 Vdc	E321K13-495905C2													

Fast Delivery

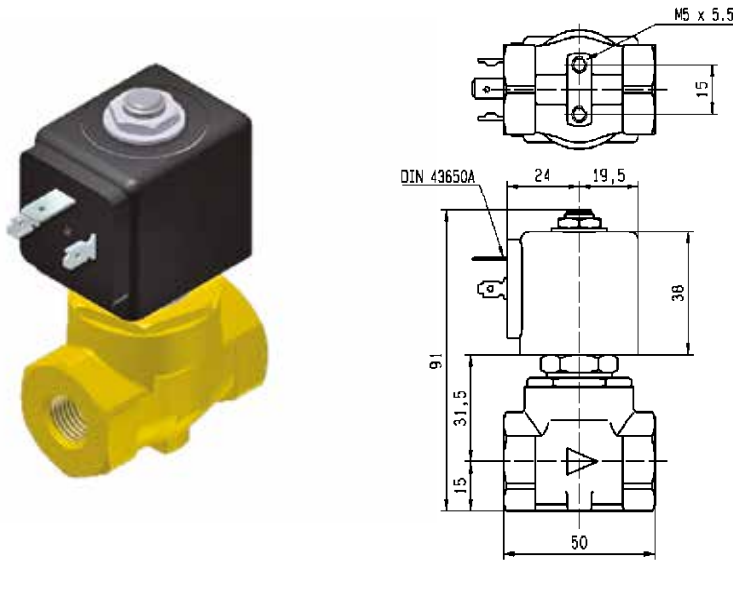

Valve	A
E321K13/63	G 3/8"
E321K10	G 1/4"



2/2

VALVES FOR ALL FLUIDS AND AIR PILOT OPERATED

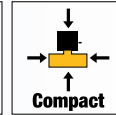
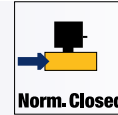

All Fluids & Air

BRASS PIPE MOUNTING NORMALLY CLOSED

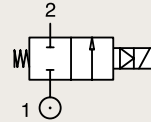

Port size BSP	Orifice Ø mm	Flow factors			Seat Seal NBR	Atex Zone	Operating Pressure Differential		Fluid Temp.		Power W	Voltage	Solenoid Valve Order Number
		Kv l/min	KV m³/h	Qn l/min			Min bar	Max bar	Min °C	Max °C			
1/2"	11	36	2.16	2500	NBR	-	0.2	10	-10	100	8	220-230V/50Hz	E321K15-2995-4818653D
							0.2	3	-10	100	9	24 Vdc	E321K15-2995-481865C2
							0.2	10	-10	120	14	24 Vdc	E321K15-2995-492425C2
						2-22	0.2	10	-10	65	8	220-230V/50Hz	E321K15-2995-4958703D
							0.2	3	-10	65	9	24 Vdc	E321K15-2995-495870C2
							1-21	0.2	10	-10	80	8	230V/50Hz
0.2	3	-10	80	8	24 Vdc	E321K15-495905C2							

ATEX

Fast Delivery

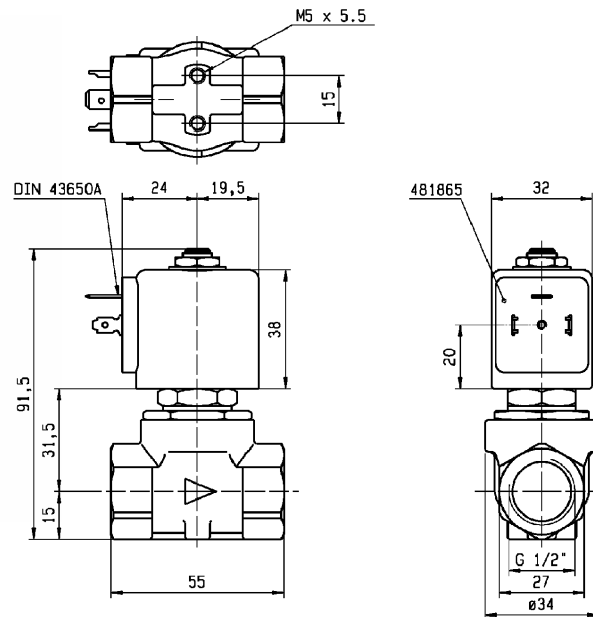

2/2

VALVES FOR ALL FLUIDS AND AIR PILOT OPERATED

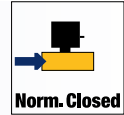

BRASS PIPE MOUNTING

NORMALLY CLOSED

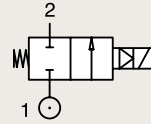

Port size	Orifice Ø	Flow factors			Seat Seal	Atex Zone	Operating Pressure Differential		Fluid Temp.		Power W	Voltage	Solenoid Valve Order Number	
		Kv l/min	KV m³/h	Qn l/min			Min bar	Max bar	Min °C	Max °C				
1/4"	12	30	1.80	2150	FKM	-	0.3	10	-10	75	2	220-230V/50Hz	321K3106-8993-4889803D ₁	
							0.3	7	-10	75	2.5	24 Vdc	321K3106-8993-488980C2 ₁	
							2-22	0.3	10	-10	50	2	220-230V/50Hz	321K3106-8993-4958653D ₁
							0.3	7	-10	50	2.5	24 Vdc	321K3106-8993-495865C2 ₁	
							1-21	0.3	10	-10	65	2	220-230V/50Hz	321K3106-4826063D ₁
							0.3	7	-10	65	2.5	24 Vdc	321K3106-482606C2 ₁	
3/8"	12	45	2.70	3050	FKM	-	0.3	10	-10	75	2	220-230V/50Hz	321K3306-8993-4889803D ₁	
							0.3	7	-10	75	2.5	24 Vdc	321K3306-8993-488980C2 ₁	
							2-22	0.3	10	-10	50	2	220-230V/50Hz	321K3306-8993-4958653D ₁
							0.3	7	-10	50	2.5	24 Vdc	321K3306-8993-495865C2 ₁	
							1-21	0.3	10	-10	65	2	220-230V/50Hz	321K3306-4826063D ₁
							0.3	7	-10	65	2.5	24 Vdc	321K3306-482606C2 ₁	

Notes:

1. Minimum pressure differential = 0.3 bar for opening and 0 bar for closing

Fast Delivery

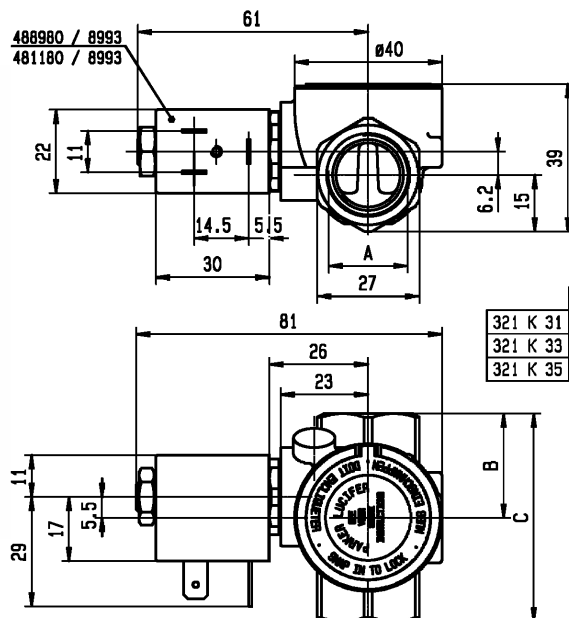

2/2

VALVES FOR ALL FLUIDS AND AIR PILOT OPERATED

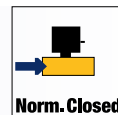

All Fluids & Air

BRASS PIPE MOUNTING NORMALLY CLOSED

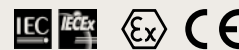
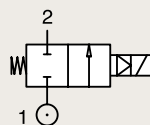

Port size	Orifice Ø	Flow factors			Seat Seal	Atex Zone	Operating Pressure Differential		Fluid Temp.		Power	Voltage	Solenoid Valve Order Number	
		Kv l/min	KV m³/h	Qn l/min			Min bar	Max bar	Min °C	Max °C				W
1/2"	12	50	3.00	3400	NBR	-	0.3	10	-10	75	2	220-230V/50Hz	321K35-8993-4889803D	
								7	-10	75	2.5	24 Vdc	321K35-8993-488980C2	
							2-22	0.3	10	-10	50	2	220-230V/50Hz	321K35-8993-4958653D
									7	-10	50	2.5	24 Vdc	321K35-8993-495865C2
							1-21	0.3	10	-10	65	2	220-230V/50Hz	321K35-4826063D
									7	-10	65	2.5	24 Vdc	321K35-482606C2
						FKM	-	0.3	10	-10	75	2	220-230V/50Hz	321K3506-8993-4889803D
									7	-10	75	2.5	24 Vdc	321K3506-8993-488980C2
							2-22	0.3	10	-10	50	2	220-230V/50Hz	321K3506-8993-4958653D
									7	-10	50	2.5	24 Vdc	321K3506-8993-495865C2
							1-21	0.3	10	-10	65	2	220-230V/50Hz	321K3506-4826063D
									7	-10	65	2.5	24 Vdc	321K3506-482606C2

Notes:

1. Minimum pressure differential = 0.3 bar for opening and 0 bar for closing

Fast Delivery

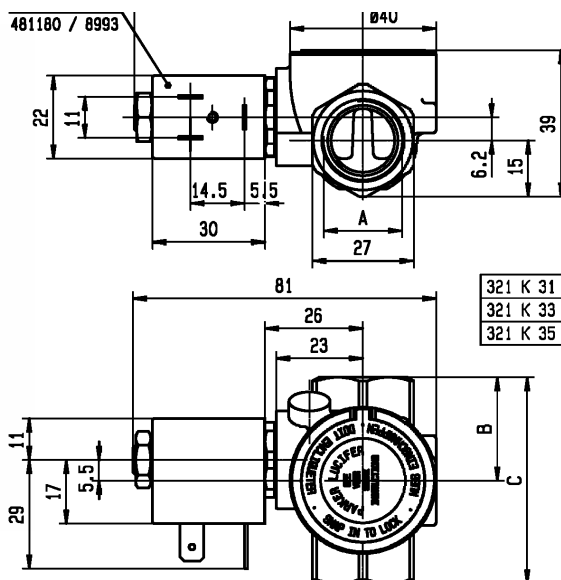

	A	B	C
321 K 31	6 1/4"	25	50
321 K 33	6 3/8"	25	50
321 K 35	6 1/2"	27,5	55



2/2

VALVES FOR ALL FLUIDS AND AIR PILOT OPERATED

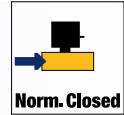

BRASS PIPE MOUNTING

NORMALLY CLOSED

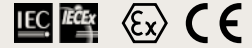
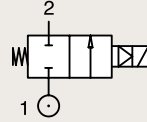

Port size	Orifice Ø	Flow factors			Seat Seal	Atex Zone	Operating Pressure Differential		Fluid Temp.		Power	Voltage	Solenoid Valve Order Number		
		Kv l/min	KV m³/h	Qn l/min			Min bar	Max bar	Min °C	Max °C				W	
3/4"	18	100	6.00	9400	NBR	-	0.3	10	-10	75	2	220-230V/50Hz	321K36-8993-4889803D ₁		
							0.3	7	-10	75	2.5	24 Vdc	321K36-8993-488980C2 ₁		
							2-22	0.3	10	-10	50	2	220-230V/50Hz	321K36-8993-4958653D ₁	
							2-22	0.3	7	-10	50	2.5	24 Vdc	321K36-8993-495865C2 ₁	
							1-21	0.3	10	-10	65	2	220-230V/50Hz	321K36-4826063D ₁	
							1-21	0.3	7	-10	65	2.5	24 Vdc	321K36-482606C2 ₁	
						FKM	-	0.3	10	-10	75	2	220-230V/50Hz	321K3606-8993-4889803D ₁	
								0.3	7	-10	75	2.5	24 Vdc	321K3606-8993-488980C2 ₁	
								2-22	0.3	10	-10	50	2	220-230V/50Hz	321K3606-8993-4958653D ₁
								2-22	0.3	7	-10	50	2.5	24 Vdc	321K3606-8993-495865C2 ₁
								1-21	0.3	10	-10	65	2	220-230V/50Hz	321K3606-4826063D ₁
								1-21	0.3	7	-10	65	2.5	24 Vdc	321K3606-482606C2 ₁

Notes:

1. Minimum pressure differential = 0.3 bar for opening and 0 bar for closing

Fast Delivery

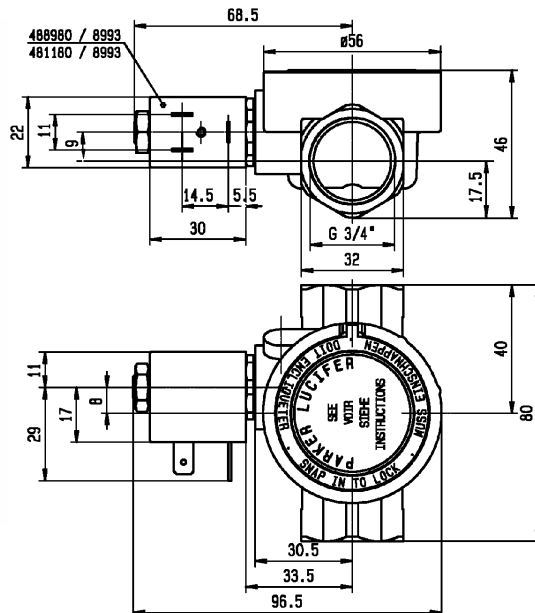

2/2

VALVES FOR ALL FLUIDS AND AIR PILOT OPERATED

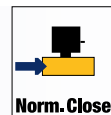

All Fluids & Air

BRASS PIPE MOUNTING NORMALLY CLOSED

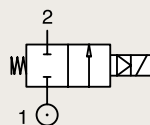

Port size	Orifice Ø	Flow factors			Seat Seal	Atex Zone	Operating Pressure Differential		Fluid Temp.		Power	Voltage	Solenoid Valve Order Number	
		Kv l/min	KV m³/h	Qn l/min			Min bar	Max bar	Min °C	Max °C				W
1"	18	110	6.60	10150	NBR	-	0.3	10	-10	75	2	220-230V/50Hz	321K37-8993-4889803D ¹	
								7	-10	75	2.5	24 Vdc	321K37-8993-488980C2 ¹	
							2-22	0.3	10	-10	50	2	220-230V/50Hz	321K37-8993-4958653D ¹
									7	-10	50	2.5	24 Vdc	321K37-8993-495865C2 ¹
							1-21	0.3	10	-10	65	2	220-230V/50Hz	321K37-4826063D ¹
									7	-10	65	2.5	24 Vdc	321K37-482606C2 ¹
						FKM	-	0.3	10	-10	75	2	220-230V/50Hz	321K3706-8993-4889803D ¹
									7	-10	75	2.5	24 Vdc	321K3706-8993-488980C2 ¹
							2-22	0.3	10	-10	50	2	220-230V/50Hz	321K3706-8993-4958653D ¹
									7	-10	50	2.5	24 Vdc	321K3706-8993-495865C2 ¹
							1-21	0.3	10	-10	65	2	220-230V/50Hz	321K3706-4826063D ¹
									7	-10	65	2.5	24 Vdc	321K3706-482606C2 ¹

Notes:

1. Minimum pressure differential = 0.3 bar for opening and 0 bar for closing

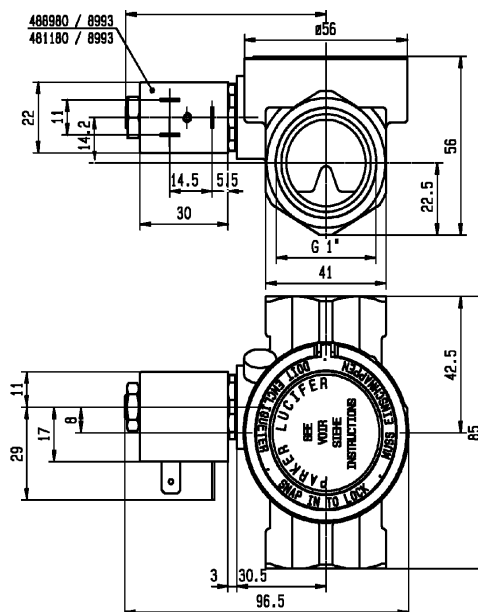

2 WAY VALVES

2/2

VALVES FOR ALL FLUIDS AND AIR PILOT OPERATED

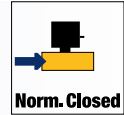

BRASS PIPE MOUNTING

NORMALLY CLOSED

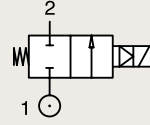

Port size	Orifice Ø	Flow factors			Seat Seal	Atex Zone	Operating Pressure Differential		Fluid Temp.		Power	Voltage	Solenoid Valve Order Number
		Kv l/min	KV m³/h	Qn l/min			Min bar	Max bar	Min °C	Max °C			
3/8"	13	33	2.00		NBR		0.5	16	-10	90	9	230V/50-60Hz	550112DIS ₁
							0.5	16	-10	90	12	24 Vdc	550111DIS ₁
1/2"		42	2.50		NBR		0.5	16	-10	90	9	230V/50-60Hz	550106DIS ₂
							0.5	16	-10	90	12	24 Vdc	550105DIS ₂
3/4"	20	117	7.00		NBR		0.5	16	-10	90	9	230V/50-60Hz	550108DIS ₂
							0.5	16	-10	90	12	24 Vdc	550107DIS ₂
1"	25	133	8.00		NBR		0.5	16	-10	90	9	230V/50-60Hz	550110DIS ₂
							0.5	16	-10	90	12	24 Vdc	550109DIS ₂

Notes:

1. Drawing number 1
2. Drawing number 2

N° 1

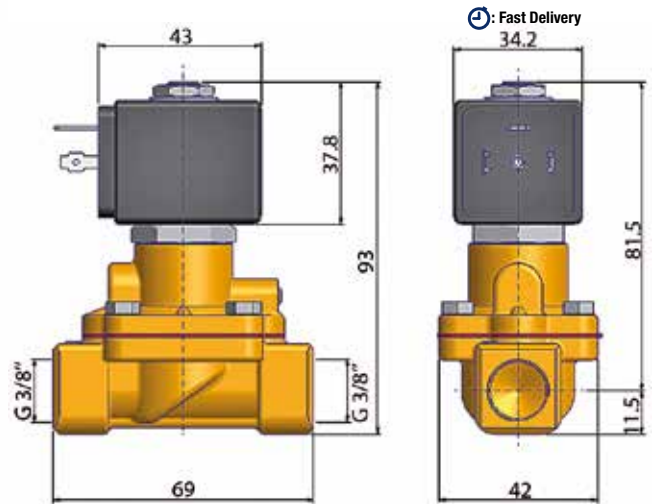

N° 2

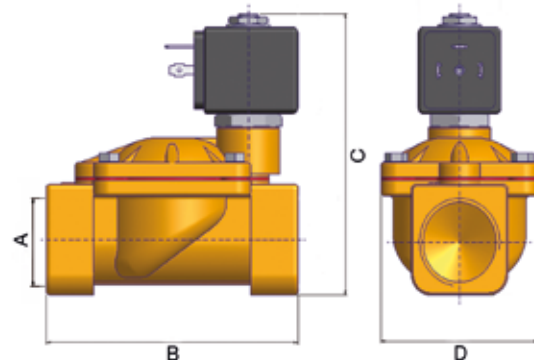
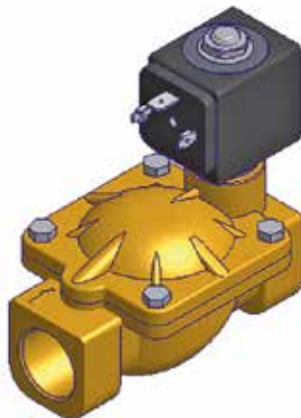

A	B	C	D
G	mm	mm	mm
3/8"	69	93.5	40
1/2"	72	95.5	40
3/4"	100	101	65
1"	104	106.5	65



2/2

VALVES FOR ALL FLUIDS AND AIR PILOT OPERATED

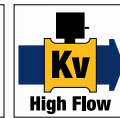
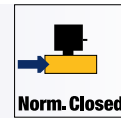

All Fluids & Air

BRASS PIPE MOUNTING NORMALLY CLOSED

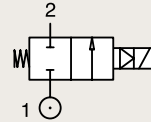

Port size BSP	Orifice Ø mm	Flow factors			Seat Seal	Atex Zone	Operating Pressure Differential		Fluid Temp.		Power W	Voltage	Solenoid Valve Order Number						
		Kv l/min	KV m³/h	Qn l/min			Min bar	Max bar	Min °C	Max °C									
1/4"	8	36	2.16	1600	NBR	-	0.3	40	-10	100	8	220-230V/50Hz	E321H11-2995-4818653D ¹²³						
							0.3	25	-10	100	9	24 Vdc	E321H11-2995-481865C2 ¹²³						
						2-22	0.3	40	-10	65	8	220-230V/50Hz	E321H11-2995-4958703D ¹²³						
							0.3	25	-10	65	9	24 Vdc	E321H11-2995-495870C2 ¹²³						
						1-21	0.3	40	-10	80	8	230V/50Hz	E321H11-495905F4 ¹²³						
							0.3	25	-10	80	8	24 Vdc	E321H11-495905C2 ¹²³						
						3/8"	11	50	3.00	2800	NBR	-	0.3	40	-10	100	8	220-230V/50Hz	E321H13-2995-4818653D ¹²³
													0.3	25	-10	100	9	24 Vdc	E321H13-2995-481865C2 ¹²³
2-22	0.3	40	-10	65	8							220-230V/50Hz	E321H13-2995-4958703D ¹²³						
	0.3	25	-10	65	9							24 Vdc	E321H13-2995-495870C2 ¹²³						
1-21	0.3	40	-10	80	8							230V/50Hz	E321H13-495905F4 ¹²³						
	0.3	25	-10	80	8							24 Vdc	E321H13-495905C2 ¹²³						

Notes:

- Pilot seat disc in synthetic Ruby
- With 4 position selector for controlled closure rate
- Minimum pressure differential = 0.3 bar for opening and 0 bar for closing

Fast Delivery

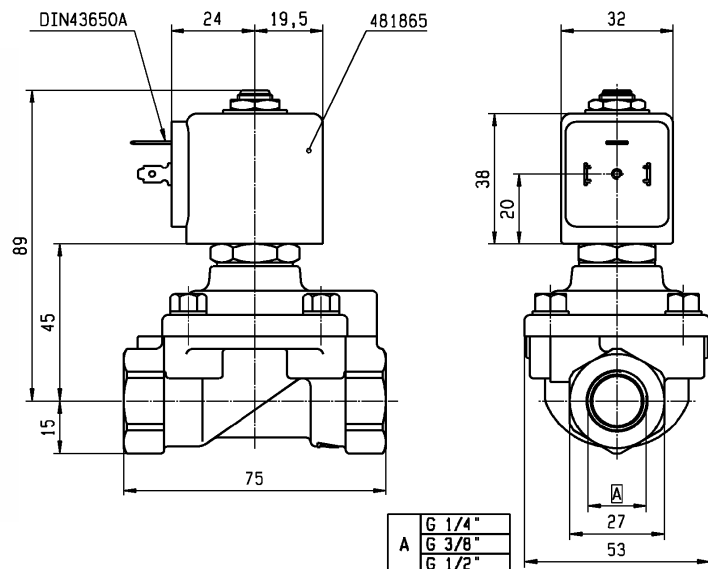

2/2

VALVES FOR ALL FLUIDS AND AIR PILOT OPERATED

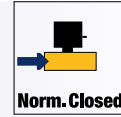

BRASS
PIPE MOUNTING

NORMALLY CLOSED

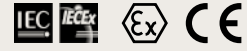
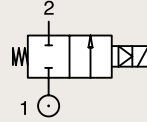

Port size	Orifice Ø	Flow factors			Seat Seal	Atex Zone	Operating Pressure Differential		Fluid Temp.		Power	Voltage	Solenoid Valve Order Number
		Kv l/min	KV m³/h	Qn l/min			Min bar	Max bar	Min °C	Max °C			
1/2"	15	60	3.60	3150	NBR	-	0.3	40	-10	100	8	220-230V/50Hz	E321H15-2995-4818653D ¹²³
							0.3	25	-10	100	9	24 Vdc	E321H15-2995-481865C2 ¹²³
							0.3	40	-10	100	14	24 Vdc	E321H15-2995-492425C2 ¹²³
						2-22	0.3	40	-10	65	8	220-230V/50Hz	E321H15-2995-4958703D ¹²³
							0.3	25	-10	65	9	24 Vdc	E321H15-2995-495870C2 ¹²³
							0.3	40	-10	80	8	230V/50Hz	E321H15-495905F4 ¹²³
1-21	0.3	25	-10	80	8	24 Vdc	E321H15-495905C2 ¹²³						

Notes:

1. Pilot seat disc in synthetic Ruby
2. With 4 position selector for controlled closure rate
3. Minimum pressure differential = 0.3 bar for opening and 0 bar for closing

Fast Delivery

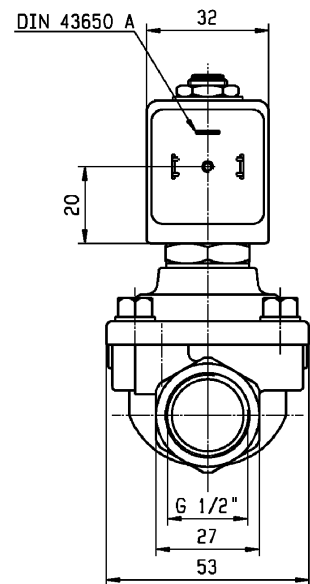
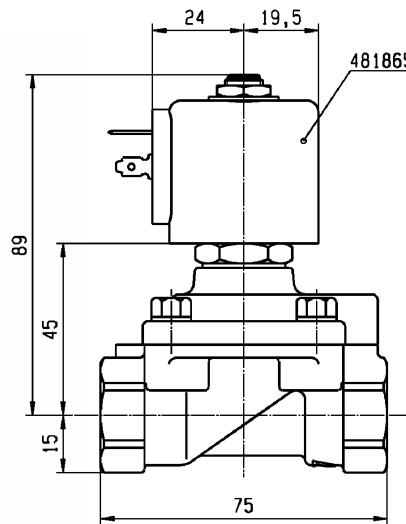

2/2

VALVES FOR ALL FLUIDS AND AIR PILOT OPERATED

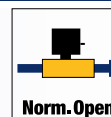

All Fluids & Air

BRASS PIPE MOUNTING NORMALLY OPEN

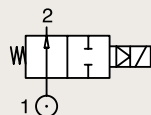

Port size BSP	Orifice Ø mm	Flow factors			Seat Seal	Atex Zone	Operating Pressure Differential		Fluid Temp.		Power W	Voltage	Solenoid Valve Order Number	
		Kv l/min	KV m³/h	Qn l/min			Min bar	Max bar	Min °C	Max °C				
1/4"	12	32	1.92	2150	FKM	-	0.3	12	-10	100	8	220-230V/50Hz	322K4106-2995-4818653D	
							0.3	12	-10	100	9	24 Vdc	322K4106-2995-481865C2	
							2-22	0.3	12	-10	65	8	220-230V/50Hz	322K4106-2995-4958703D
								0.3	12	-10	65	9	24 Vdc	322K4106-2995-495870C2
							1-21	0.3	12	-10	80	8	230V/50Hz	322K4106-495905F4
								0.3	12	-10	80	8	24 Vdc	322K4106-495905C2
1/2"	50	3.00	3400	FKM	-	0.3	12	-10	100	8	220-230V/50Hz	322K4506-2995-4818653D		
						0.3	12	-10	100	9	24 Vdc	322K4506-2995-481865C2		
						2-22	0.3	12	-10	65	8	220-230V/50Hz	322K4506-2995-4958703D	
							0.3	12	-10	65	9	24 Vdc	322K4506-2995-495870C2	
						1-21	0.3	12	-10	80	8	230V/50Hz	322K4506-495905F4	
							0.3	12	-10	80	8	24 Vdc	322K4506-495905C2	
3/4"	18	100	6.00	FKM	-	0.3	12	-10	120	8	220-230V/50Hz	322K4606-2995-4818653D		
						0.3	12	-10	120	9	24 Vdc	322K4606-2995-481865C2		
						2-22	0.3	12	-10	65	8	220-230V/50Hz	322K4606-2995-4958703D	
							0.3	12	-10	65	9	24 Vdc	322K4606-2995-495870C2	
						1-21	0.3	12	-10	80	8	230V/50Hz	322K4606-495905F4	
							0.3	12	-10	80	8	24 Vdc	322K4606-495905C2	

Notes:

1. Minimum pressure differential = 0.3 bar for opening and 0 bar for closing

Fast Delivery

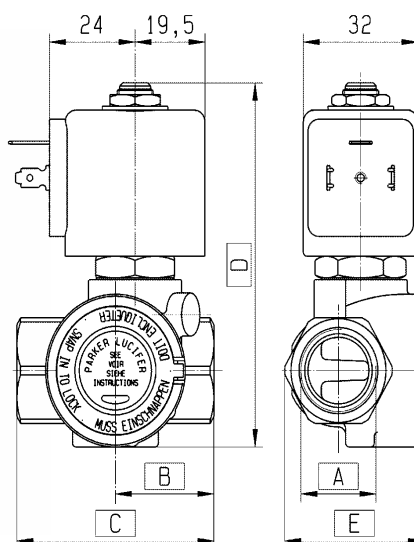

	A	B	C	D	E
G 1/4"	25	50	93,5	39	
G 1/2"	27,5	55	93,5	39	
G 3/4"	40	80	109	47	



2/2

VALVES FOR ALL FLUIDS AND AIR PILOT OPERATED

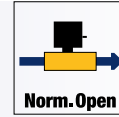

BRASS
PIPE MOUNTING

NORMALLY OPEN

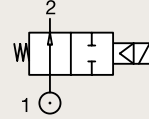

Port size	Orifice Ø	Flow factors			Seat Seal	Atex Zone	Operating Pressure Differential		Fluid Temp.		Power	Voltage	Solenoid Valve Order Number			
		Kv l/min	KV m³/h	Qn l/min			Min bar	Max bar	Min °C	Max °C				W		
1/2"	15	60	3.60	3890	NBR	-	0.3	40	-10	100	8	220-230V/50Hz	322H75-2995-4818653D			
							0.3	40	-10	100	9	24 Vdc	322H75-2995-481865C2			
							2-22	0.3	40	-10	65	8	220-230V/50Hz	322H75-2995-4958703D		
								0.3	40	-10	65	9	24 Vdc	322H75-2995-495870C2		
							1-21	0.3	40	-10	80	8	230V/50Hz	322H75-495905F4		
								0.3	40	-10	80	8	24 Vdc	322H75-495905C2		
							FKM	-	0.3	40	-10	100	8	220-230V/50Hz	322H7506-2995-4818653D	
									0.3	40	-10	100	9	24 Vdc	322H7506-2995-481865C2	
									2-22	0.3	40	-10	65	8	220-230V/50Hz	322H7506-2995-4958703D
										0.3	40	-10	65	9	24 Vdc	322H7506-2995-495870C2
									1-21	0.3	40	-10	80	8	230V/50Hz	322H7506-495905F4
										0.3	40	-10	80	8	24 Vdc	322H7506-495905C2

Fast Delivery

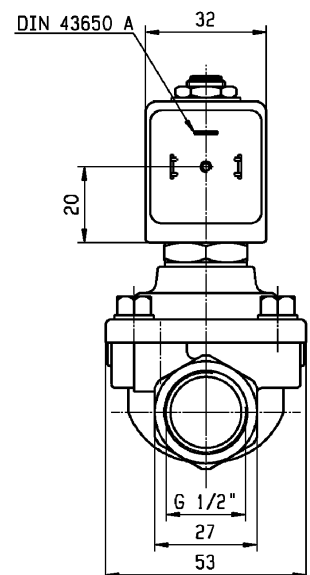
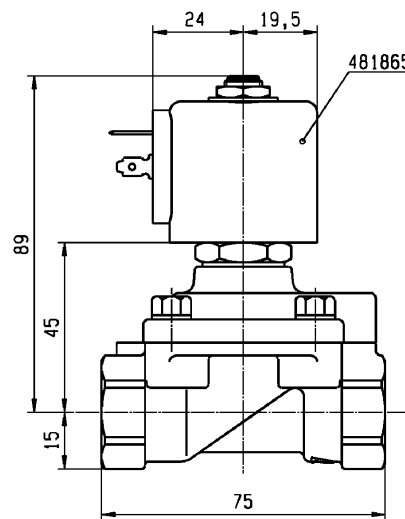

2/2

VALVES FOR ALL FLUIDS AND AIR PILOT OPERATED

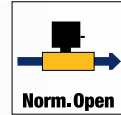

All Fluids & Air

BRASS
PIPE MOUNTING
NORMALLY OPEN

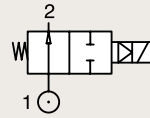

Port size	Orifice Ø	Flow factors			Seat Seal	Atex Zone	Operating Pressure Differential		Fluid Temp.		Power	Voltage	Solenoid Valve Order Number	
		Kv l/min	KV m³/h	Qn l/min			Min bar	Max bar	Min °C	Max °C				W
1/2"	15	60	3.60	3890	NBR	2-22	0.3	15	-10	100	8	220-230V/50Hz	322G75-2995-4818653D	
							0.3	15	-10	100	9	24 Vdc	322G75-2995-481865C2	
							0.3	15	-10	65	8	220-230V/50Hz	322G75-2995-4958703D	
							0.3	15	-10	65	9	24 Vdc	322G75-2995-495870C2	
							1-21	0.3	15	-10	80	8	230V/50Hz	322G75-495905F4
								0.3	15	-10	80	8	24 Vdc	322G75-495905C2

Fast Delivery

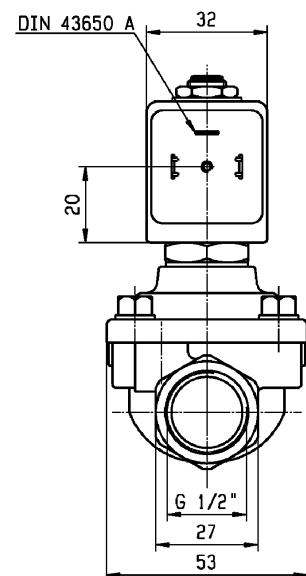
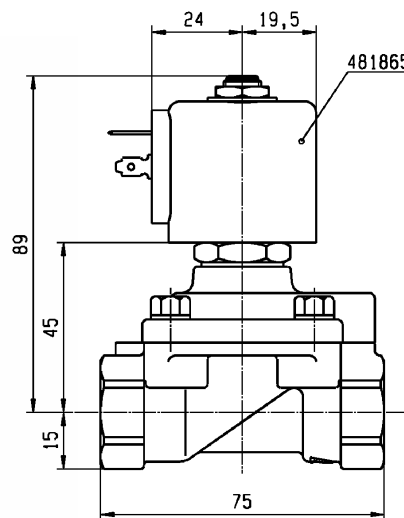

2 WAY VALVES

ATEX

2/2

VALVES FOR ALL FLUIDS AND AIR MAGNALIFT



BRASS PIPE MOUNTING

NORMALLY CLOSED

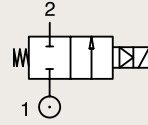

Port size	Orifice Ø	Flow factors			Seat Seal	Atex Zone	Operating Pressure Differential		Fluid Temp.		Power	Voltage	Solenoid Valve Order Number
		Kv l/min	KV m³/h	Qn l/min			Min bar	Max bar	Min °C	Max °C			
3/8"	13	40	2.40	-	FKM	-	0	5	-10	140	9	230V/50-60Hz	550066DIS ₁
1/2"	20	100	6.00	-			0	5	-10	140	9	230V/50-60Hz	550064DIS ₂
3/4"	25	117	7.00	-			0	3	-10	140	14	230V/50-60Hz	550065DIS ₃
1"	32	140	8.50	-			0	3	-10	140	14	230V/50-60Hz	550071DIS ₄

Notes:

1. Drawing number 1
2. Drawing number 2
3. Drawing number 3
4. Drawing number 4

Fast Delivery

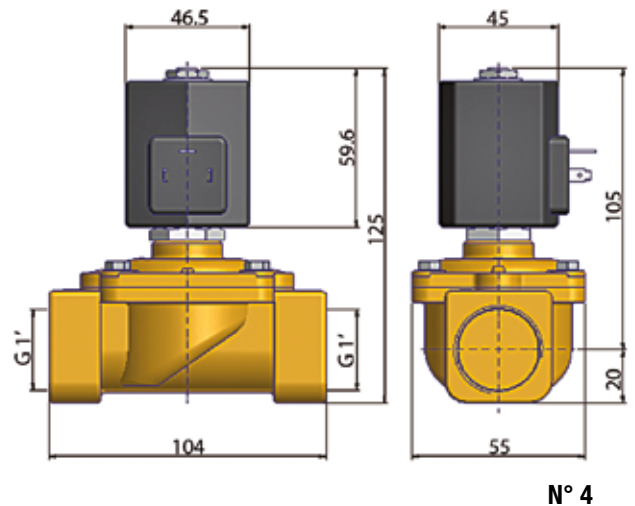
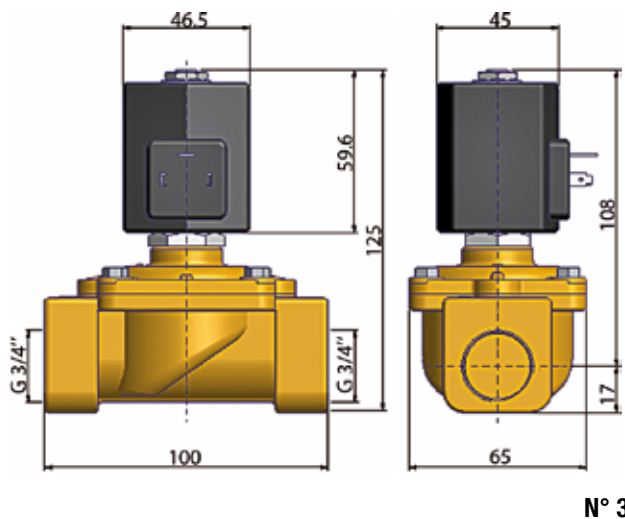
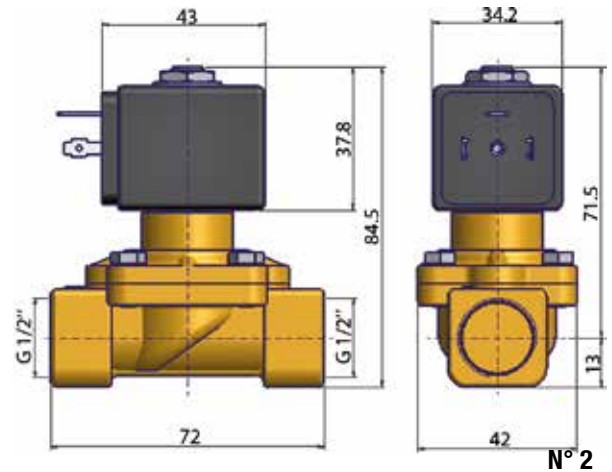
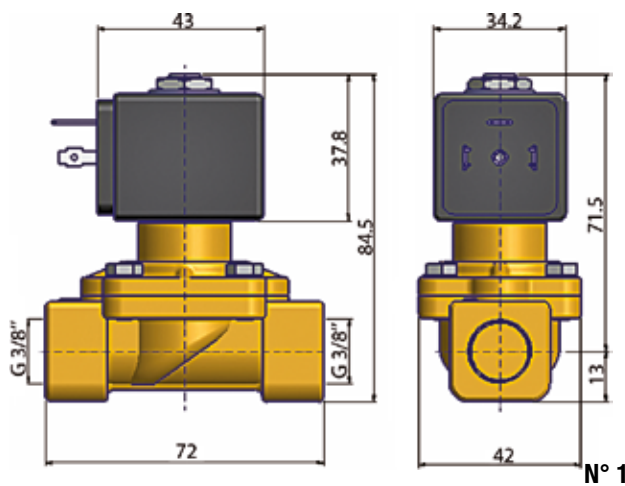

2/2

VALVES FOR ALL FLUIDS AND AIR MAGNALIFT

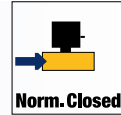

All Fluids & Air

BRASS PIPE MOUNTING NORMALLY CLOSED

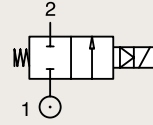

Port size	Orifice Ø	Flow factors			Seat Seal	Atex Zone	Operating Pressure Differential		Fluid Temp.		Power	Voltage	Solenoid Valve Order Number	
		Kv l/min	KV m³/h	Qn l/min			Min bar	Max bar	Min °C	Max °C				W
3/8"	15	65	3.90	4500	NBR	-	0	16	-10	100	8	220-230V/50Hz	221G13-2995-4818653D	
							0	6	-10	100	14	24 Vdc	221G13-2995-492425C2	
						2-22	0	16	-10	65	8	220-230V/50Hz	221G13-2995-4958703D	
						1-21	0	16	-10	80	8	230V/50Hz	221G13-495905F4	
						2-22	0	16	-10	65	8	220-230V/50Hz	221G15-2995-4818653D	
						1-21	0	16	-10	80	8	230V/50Hz	221G15-2995-492425C2	
1/2"	15	65	3.90	4500		FKM	-	0	16	-10	100	8	220-230V/50Hz	221G1530-2995-4818653D
								0	6	-10	100	14	24 Vdc	221G1530-2995-492425C2
							2-22	0	16	-10	65	8	220-230V/50Hz	221G1530-2995-495870C2
							1-21	0	16	-10	80	8	24 Vdc	221G1530-495905C2
							2-22	0	16	-10	65	8	220-230V/50Hz	221G25-2995-4818653D
							1-21	0	16	-10	80	8	230V/50Hz	221G25-2995-4958703D
1/2"	15	65	3.90	4500	FKM		-	0	16	0	100	8	220-230V/50Hz	221G2530-2995-4818653D
								0	5	0	100	14	24 Vdc	221G25-2995-492425C2
							2-22	0	16	0	65	8	220-230V/50Hz	221G25-2995-4958703D
							1-21	0	16	0	80	8	230V/50Hz	221G25-495905F4
							2-22	0	16	-10	65	8	24 Vdc	221G2530-2995-481865C2
							1-21	0	16	-10	80	8	24 Vdc	221G2530-2995-495870C2

Fast Delivery

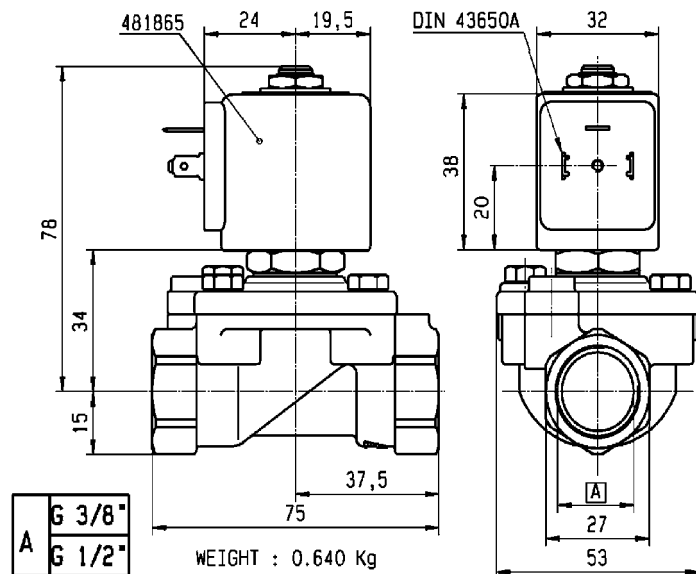

2/2

VALVES FOR ALL FLUIDS AND AIR MAGNALIFT

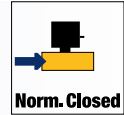

BRASS PIPE MOUNTING

NORMALLY CLOSED

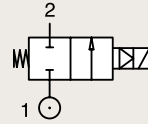

Port size	Orifice Ø	Flow factors			Seat Seal	Atex Zone	Operating Pressure Differential		Fluid Temp.		Power	Voltage	Solenoid Valve Order Number						
		Kv l/min	KV m³/h	Qn l/min			Min bar	Max bar	Min °C	Max °C				W					
3/4"	15.00	80	4.80	6000	NBR	-	0	16	-10	100	8	220-230V/50Hz	221G16-2995-4818653D						
						-	0	6	-10	100	14	24 Vdc	221G16-2995-492425C2						
						2-22	0	16	-10	65	8	220-230V/50Hz	221G16-2995-4958703D						
						1-21	0	16	-10	80	8	230V/50Hz	221G16-495905F4						
						-	0	16	0	100	8	220-230V/50Hz	221G26-2995-4818653D						
						-	0	5	0	100	14	24 Vdc	221G26-2995-492425C2						
					FKM	2-22	0	16	0	65	8	220-230V/50Hz	221G26-2995-4958703D						
						1-21	0	16	0	80	8	230V/50Hz	221G26-495905F4						
						1"	25.00	170	10.20	14000	NBR	-	0	16	-10	100	8	220-230V/50Hz	221G17-2995-4818653D
												-	0	6	-10	100	14	24 Vdc	221G17-2995-492425C2
												2-22	0	16	-10	65	8	220-230V/50Hz	221G17-2995-4958703D
												1-21	0	16	-10	80	8	230V/50Hz	221G17-495905F4
-	0	16	-10	100	8							220-230V/50Hz	221G21-2995-4818653D						
-	0	6	-10	100	14							24 Vdc	221G21-2995-492425C2						
FKM	2-22	0	16	-10	65	8					220-230V/50Hz	221G21-2995-4958703D							
	1-21	0	16	-10	80	8					230V/50Hz	221G21-495905F4							
	-	0	10	-10	100	9					24 Vdc	221G2130-2995-481865C2							
	2-22	0	10	-25	40	9					24 Vdc	221G2130-2995-495870C2							
	1-21	0	10	-25	40	8					24 Vdc	221G2130-495905C2							

Fast Delivery

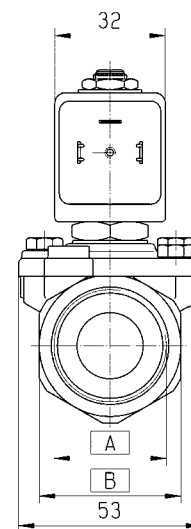
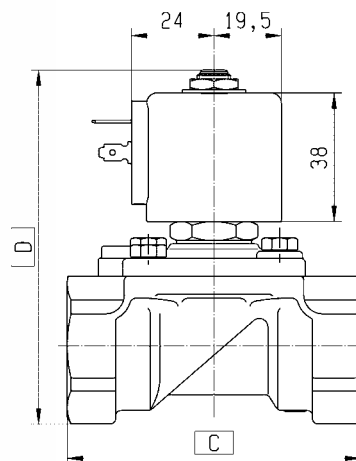

	A	B	C	D
G 3/4"	35	80	95,5	
G 1"	41	85	102,5	



2/2

VALVES FOR ALL FLUIDS AND AIR MAGNALIFT

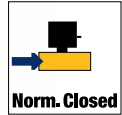

All Fluids & Air

316L STAINLESS ST.
PIPE MOUNTING

NORMALLY CLOSED

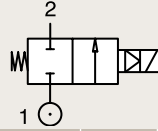

Port size	Orifice Ø	Flow factors			Seat Seal	Atex Zone	Operating Pressure Differential		Fluid Temp.		Power	Voltage	Solenoid Valve Order Number
		Kv l/min	KV m³/h	Qn l/min			Min bar	Max bar	Min °C	Max °C			
3/8"	15	40	2.40	-	FKM	-	0	10	-10	85	8	220-230V/50Hz	221S10F-2995-4818653D
1/2"		50	3.00				0	10	-10	85	8	220-230V/50Hz	221S15F-2995-4818653D
3/4"	24	95	5.70				0	10	-10	85	8	220-230V/50Hz	221S20F-2995-4818653D
1"		105	6.30				0	10	-10	85	8	220-230V/50Hz	221S25F-2995-4818653D

Fast Delivery

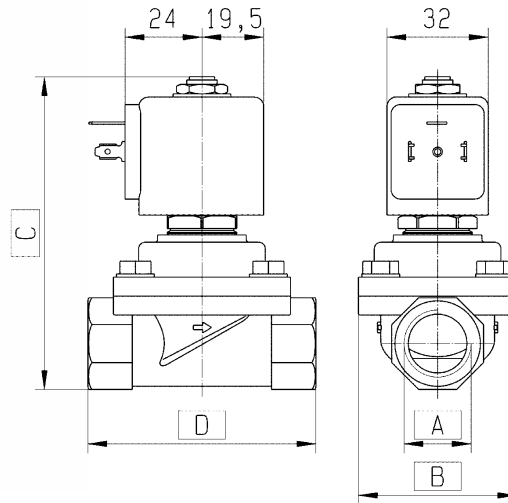

	A	B	C	D
G 3/8"	50	100	72	
G 1/2"	50	100	72	
G 3/4"	61	117	72	
G 1"	61	117	83	



2 WAY VALVES

2/2

VALVES FOR ALL FLUIDS AND AIR AIR OPERATED

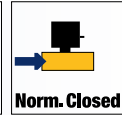

316L S.STEEL BODY / 304 S.STEEL ACTUATOR



PIPE MOUNTING

NORMALLY CLOSED

Port size	Orifice Ø	Actuator size	Flow factors			Seat Seal	Atex Zone	Operating Pressure Differential		Fluid Temp.		Pilot Control Pressure Min / Max	Flow Direction	Solenoid Valve Order Number
			Kv l/min	KV m³/h	Qn l/min			Min bar	Max bar	Min °C	Max °C			
3/8"	13	32	78	4.70	-	PTFE	2-22	0	16	-10	180	4.5-6	Over Seat	PA10C1G3R032S ₁
		0						6	-10	180	5-6	Under Seat	PA10C2G3R032S ₁	
		0						16	-10	180	3	Over Seat	PA10S1G3R050S ₂	
1/2"	13	50	78	4.70	-	PTFE	2-22	0	16	-10	180	4.5	Under Seat	PA10SAG3R050S ₂
		0						16	-10	180	4.5-6	Over Seat	PA15C1G4R032S ₁	
		0						6	-10	180	5-6	Under Seat	PA15C2G4R032S ₁	
		0						16	-10	180	4	Over Seat	PA15S1G4R040S ₂	
1/2"	13	40	78	4.70	-	PTFE	2-22	0	16	-10	180	3	Over Seat	PA15S1G4R050S ₂
		0						16	-10	180	4.5	Under Seat	PA15SAG4R050S ₂	

+ ATEX

Notes:

- Drawing number 1
- Drawing number 2

Fast Delivery

For liquids use valve with flow direction under the seat. Maximum pressure for steam: 4 Bar (140°C) to avoid anti water hammer effect.



N° 1

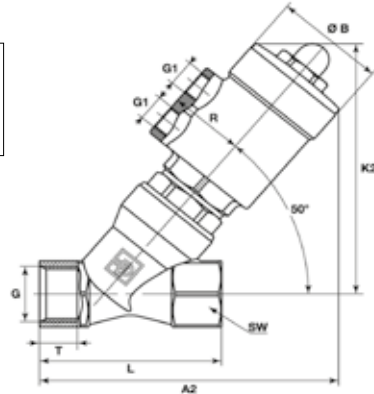
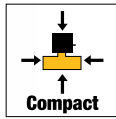

G	Actuator	Ø B	R	G1	K2 Type C1/C2 (180°C)	A2 Type C1/C2 (180°C)	L	T	SW
G 3/8"	32	39.6	27	G1/8	107	117	60	10	22 hexagon
G 1/2"	32	39.6	27	G1/8	109	119	65	11.5	25 hexagon



N° 2

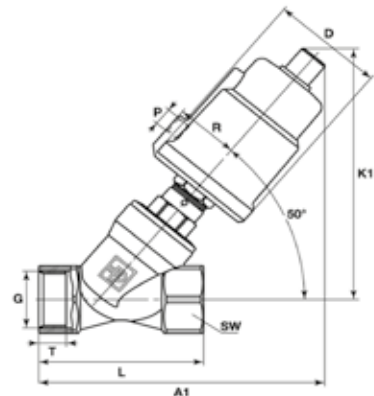

G	Actuator	D	R	P	K1	A1	L	T	SW
G 3/8"	40	50.5	27	G1/8	116	121	60	10	22 hexagon
	50	62	34	G1/8	130	133	60	10	22 hexagon
G 1/2"	40	50.5	27	G1/8	118	124	65	11.5	25 hexagon
	50	62	34	G1/8	131	135	65	11.5	25 hexagon

Please select pilot control valves within page 60

Warning : Check minimum operating control pressure page 40



2/2

VALVES FOR ALL FLUIDS AND AIR AIR OPERATED

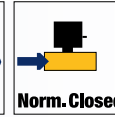

All Fluids & Air

316L S.STEEL BODY / 304 S.STEEL ACTUATOR



PIPE MOUNTING

NORMALLY CLOSED

Port size	Orifice Ø	Actuator size	Flow factors			Seat Seal	Atex Zone	Operating Pressure Differential		Fluid Temp.		Pilot Control Pressure Min / Max	Flow Direction	Solenoid Valve Order Number
			Kv l/min	KV m³/h	Qn l/min			Min bar	Max bar	Min °C	Max °C			
3/4"	15	32	90	5.40	-	PTFE	2-22	0	14	-10	180	4.5-6	Over Seat	PA20C1G5R032S ₁
	18	50	150	9.00				0	4	-10	180	5-6	Under Seat	PA20C2G5R032S ₁
								0	16	-10	180	3-4	Over Seat	PA20S1G5R050S ₂
1"	24	63	267	16.00				0	10	-10	180	4.5	Under Seat	PA20SAG5R050S ₂
								0	16	-10	180	3-5.5	Over Seat	PA25S1G6R063S ₂
		0	16	-10				180	3-3.5	Over Seat	PA25S1G6R063S ₂			
1 1/4"	31	80	400	24.00	0	8	-10	180	4.5	Under Seat	PA25SAG6R063S ₂			
					0	16	-10	180	3-5	Over Seat	PA32S1G7R063S ₂			
		0	11	-10	180	4	Under Seat	PA32SAG7R080S ₂						

+ ATEX

Notes:

- Drawing number 1
- Drawing number 2

Fast Delivery

For liquids use valve with flow direction under the seat to avoid anti water hammer effect.



N° 1

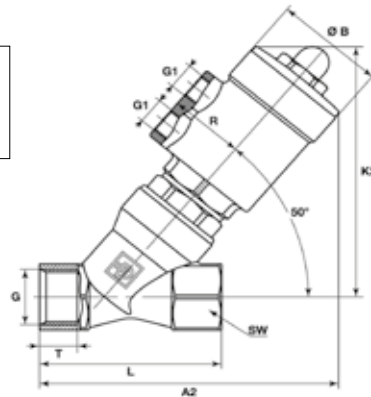
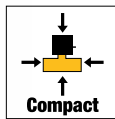

G	Actuator	Ø B	R	G1	K2	A2	L	T	SW
G 3/4"	32	39.6	27	G1/8	Type C1/C2 (180°C)	Type C1/C2 (180°C)	75	14	31 hexagon



N° 2

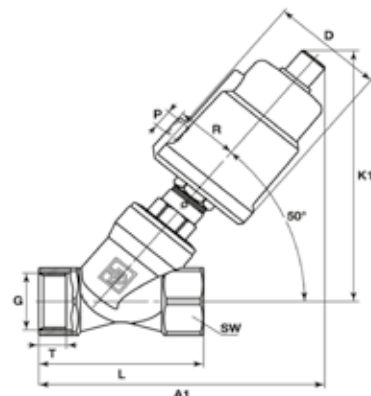

G	Actuator	D	R	P	K1	A1	L	T	SW
G 3/4"	50	62	34	G1/8	134	141	75	14	31 hexagon
G 1"	50	62	34	G1/8	141	153	90	15	39 hexagon
	63	77	41.5	G1/8	164	175	90	15	39 hexagon
G1-1/4"	63	77	41.5	G1/8	170	188	110	18	50 octagon
	80	98	52	G1/4	184	205	110	18	50 octagon

Please select pilot control valves within page 60

Warning : Check minimum operating control pressure page 40



2/2

VALVES FOR ALL FLUIDS AND AIR AIR OPERATED

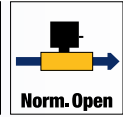

316L S.STEEL BODY / 304 S.STEEL ACTUATOR



PIPE MOUNTING

NORMALLY OPEN

Port size	Orifice Ø	Actuator size	Flow factors			Seat Seal	Atex Zone	Operating Pressure Differential		Fluid Temp.		Pilot Control Pressure Min / Max	Flow Direction	Solenoid Valve Order Number
			Kv l/min	KV m³/h	Qn l/min			Min bar	Max bar	Min °C	Max °C			
3/8"	13	50	78	4.70	-	PTFE	2-22	0	16	-10	180	3.5	Over Seat	PA10S2G3R050S
1/2"	18		150	9.00				0	16	-10	180	3.5	Over Seat	PA15S2G4R050S
3/4"	24	63	267	16.00	-	PTFE	2-22	0	16	-10	180	4.5	Over Seat	PA20S2G5R050S
1"	31		400	24.00				0	14	-10	180	4.5	Over Seat	PA25S2G6R063S
1 1/4"														PA32S2G7R063S

+ATEX

Fast Delivery

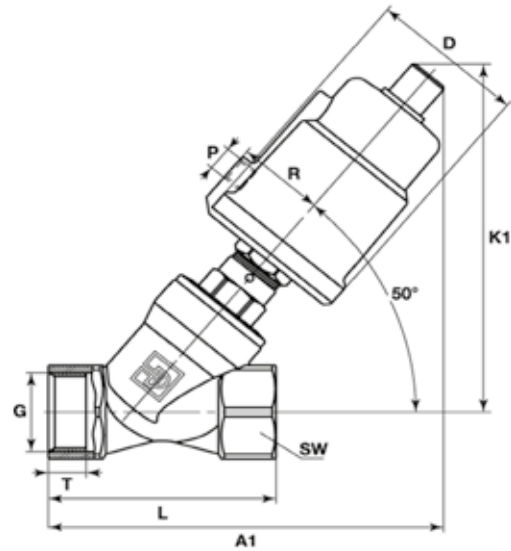

G	Actuator	D	R	P	K1	A1	L	T	SW
G 3/8"	40	50.5	27	G1/8	116	121	60	10	22 hexagon
	50	62	34	G1/8	130	133	60	10	22 hexagon
G 1/2"	40	50.5	27	G1/8	118	124	65	11.5	25 hexagon
	50	62	34	G1/8	131	135	65	11.5	25 hexagon
G 3/4"	50	62	34	G1/8	134	141	75	14	31 hexagon
G 1"	50	62	34	G1/8	141	153	90	15	39 hexagon
	63	77	41.5	G1/8	164	175	90	15	39 hexagon
G 1-1/4"	63	77	41.5	G1/8	170	188	110	18	50 octagon
	80	98	52	G1/4	184	205	110	18	50 octagon

Please select pilot control valves within page 60
Warning : Check minimum operating control pressure page 40



2/2

VALVES FOR ALL FLUIDS AND AIR AIR OPERATED

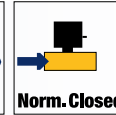

All Fluids & Air

2 WAY VALVES

316L S.STEEL BODY / ALUMINIUM ACTUATOR



PIPE MOUNTING

NORMALLY CLOSED

Port size	Orifice Ø	Actuator size	Flow factors			Seat Seal	Atex Zone	Operating Pressure Differential		Fluid Temp.		Pilot Control Pressure Min / Max	Flow Direction	Solenoid Valve Order Number
			Kv l/min	KV m³/h	Qn l/min			Min bar	Max bar	Min °C	Max °C			
1/2"	13	50	78	4.70	-	PTFE	2-22	0	16	-10	180	3	Over Seat	PA15S1G4R050A
			0	16				-10	180	4.5	Under Seat	PA15SAG4R050A		
3/4"	18	63	150	9.00	-	PTFE	2-22	0	16	-10	180	3-4	Over Seat	PA20S1G5R050A
			0	10				-10	180	4.5	Under Seat	PA20SAG5R050A		
1"	24		267	16.00				0	8	-10	180	4.5	Under Seat	PA25SAG6R063A

+ ATEX

For liquids use valve with flow direction under the seat to avoid anti water hammer effect.

Fast Delivery

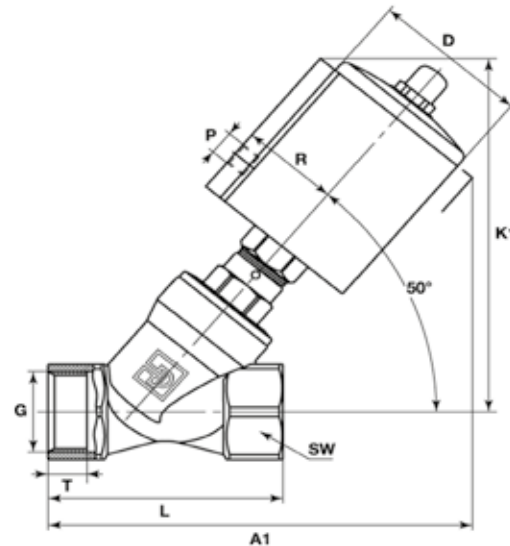

G	Actuator	D	R	P	K1	A1	L	T	SW
G 1/2"	50	61	38	G1/8	133	144	65	11.5	25 hexagon
G 3/4"	50	61	38	G1/8	136	150	75	14	31 hexagon
G 1"	50	61	38	G1/8	144	162	90	15	39 hexagon
	63	75	45	G1/8	167	183	90	15	39 hexagon

Please select pilot control valves within page 60
Warning : Check minimum operating control pressure page 40



Control Pressure & Operating Pressure Charts for Air Operated Valves with flow direction over seat

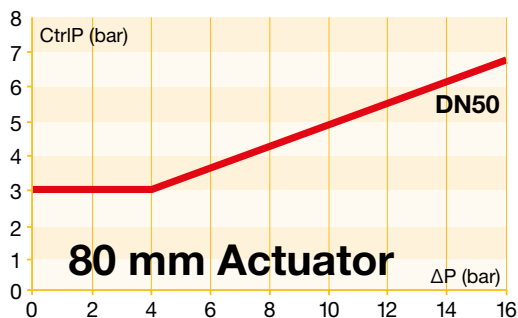
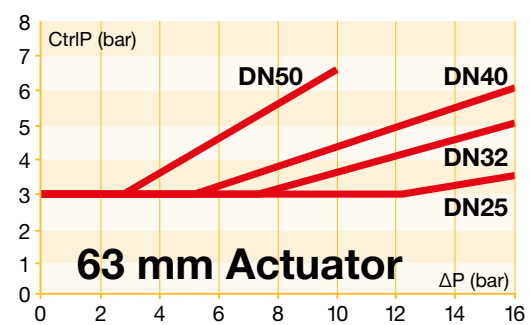
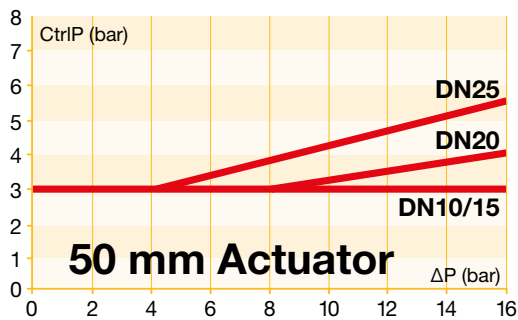
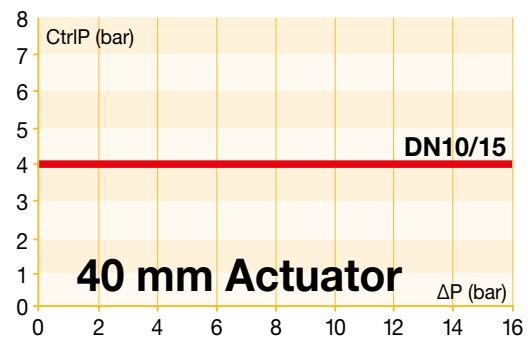
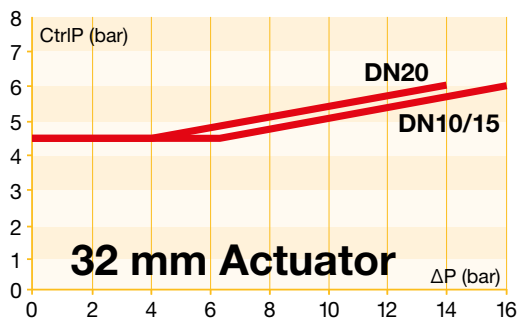

2/2

VALVES FOR WATER



The Parker 2 way valves (1 way for inlet and 1 way for outlet) for water and neutral liquids are optimized constructions for liquids handling. The exclusive diaphragm design gives a superior flow rate with one of the fastest response time.

Typical applications are:

- Water and hot water supply in plumbing installations
- Breeding
- Irrigation
- Industrial washing machines
- Car washing systems
- Fire fighting

These applications can be found in many markets dealing with water and hot water like plumbing, industries, water treatment, transportation, medical, process, etc...

Actuation	Body	Function	Specification	Port Size	Orifice (mm)	MOPD (bar)	Page
Pilot Operated (No minimum pressure required)	Brass/ Pipe Mounting	Normally Closed	-	3/8" to 2"	13 to 50	20	42
			Manual override	1/2"	13	20	47
			Big Orifice / Anti water hammer / Manual override	2 1/2" to 3"	65 to 75	10	48
		Normally Open	-	3/8" to 2"	13 to 50	20	49

2/2

VALVES FOR WATER PILOT OPERATED



BRASS PIPE MOUNTING

NORMALLY CLOSED

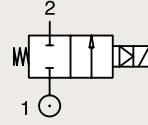

Port size	Orifice Ø	Flow factors			Seat Seal	Atex Zone	Operating Pressure Differential		Fluid Temp.		Power	Voltage	Solenoid Valve Order Number	
		Kv l/min	KV m³/h	Qn l/min			Min bar	Max bar	Min °C	Max °C				W
3/8"	13	50	3.00	-	EPDM	-	0.1	10	-10	140	8	220-230V/50Hz	550037DIS	
							0.1	10	-10	140	9	24 Vdc	550036DIS	
							0.1	20	-10	90	8	220-230V/50Hz	550039DIS	
							0.1	20	-10	90	9	24 Vdc	550038DIS	
							0.1	20	-10	140	8	220-230V/50Hz	550041DIS	
					FKM	2-22	0.1	20	-10	140	9	24 Vdc	550040DIS	
							0.1	20	-10	50	8	220-230V/50Hz	550176DIS	
							0.1	20	-10	50	9	24 Vdc	550175DIS	
							1-21	0.1	20	-10	80	8	230V/50Hz	550136DIS
								0.1	20	-10	80	8	24 Vdc	550135DIS

Fast Delivery

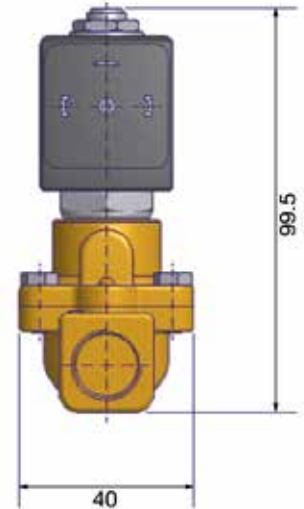
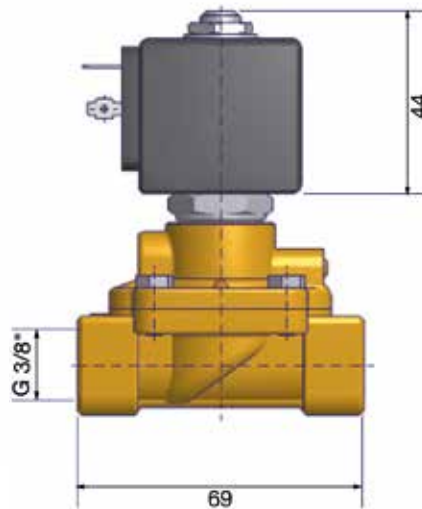

2/2

VALVES FOR WATER PILOT OPERATED

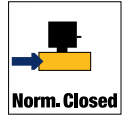

BRASS PIPE MOUNTING NORMALLY CLOSED

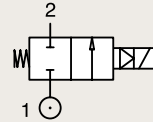

Port size BSP	Orifice Ø mm	Flow factors			Seat Seal	Atex Zone	Operating Pressure Differential		Fluid Temp.		Power W	Voltage	Solenoid Valve Order Number	
		Kv l/min	KV m³/h	Qn l/min			Min bar	Max bar	Min °C	Max °C				
1/2"	13	50	3.00	-	EPDM	-	0.1	10	-10	140	8	220-230V/50Hz	550019DIS	
							0.1	10	-10	140	9	24 Vdc	550018DIS	
							0.1	20	-10	90	8	220-230V/50Hz	550021DIS	
							0.1	20	-10	90	9	24 Vdc	550020DIS	
					FKM		2-22	0.1	20	-10	140	8	220-230V/50Hz	550025DIS
								0.1	20	-10	140	9	24 Vdc	550024DIS
							1-21	0.1	20	-10	50	8	220-230V/50Hz	550160DIS
								0.1	20	-10	50	9	24 Vdc	550159DIS
						0.1	20	-10	80	8	230V/50Hz	550120DIS		
						0.1	20	-10	80	8	24 Vdc	550119DIS		

ATEX

Fast Delivery

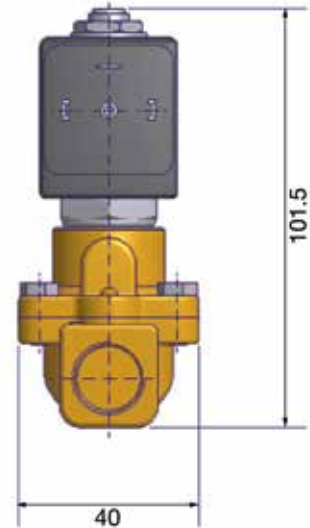
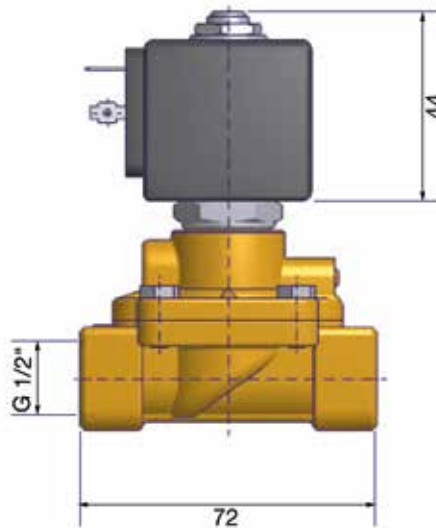
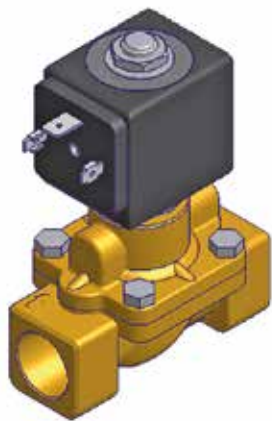

2 WAY VALVES

Water



2/2

VALVES FOR WATER PILOT OPERATED

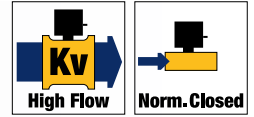

BRASS PIPE MOUNTING

NORMALLY CLOSED

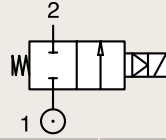

Port size	Orifice Ø	Flow factors		Seat Seal	Atex Zone	Operating Pressure Differential		Fluid Temp.		Power	Voltage	Solenoid Valve Order Number
		Kv l/min	KV m³/h			Min bar	Max bar	Min °C	Max °C			
3/4"	20	140	8.40	EPDM	-	0.1	10	-10	140	8	220-230V/50Hz	550027DIS
						0.1	10	-10	140	9	24 Vdc	550026DIS
						0.1	20	-10	90	8	220-230V/50Hz	550198DIS
						0.1	20	-10	90	9	24 Vdc	550197DIS
						0.1	20	-10	140	8	220-230V/50Hz	550200DIS
						0.1	20	-10	140	9	24 Vdc	550199DIS
				FKM	2-22	0.1	20	-10	65	8	220-230V/50Hz	550212DIS
						0.1	20	-10	65	9	24 Vdc	550211DIS
						0.1	20	-10	80	8	230V/50Hz	550202DIS
					1-21	0.1	20	-10	80	8	24 Vdc	550201DIS

Fast Delivery

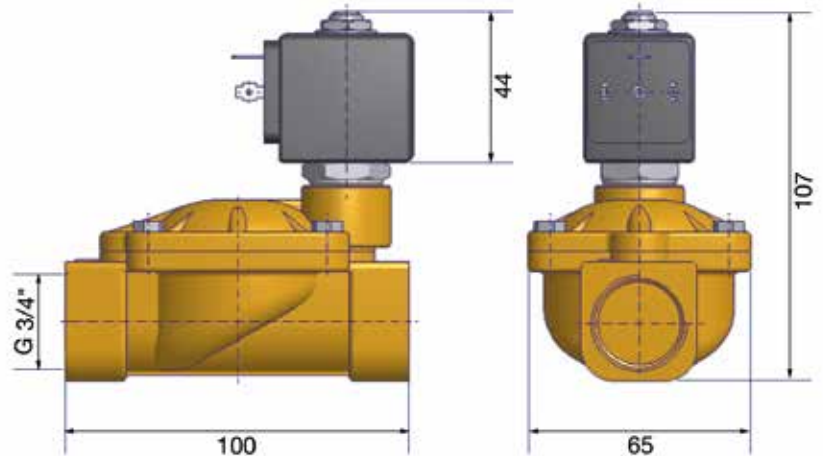
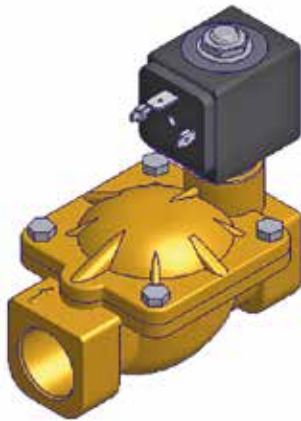

2/2

VALVES FOR WATER PILOT OPERATED

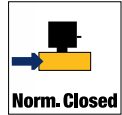

BRASS PIPE MOUNTING NORMALLY CLOSED

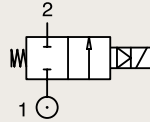

Port size	Orifice Ø	Flow factors			Seat Seal	Atex Zone	Operating Pressure Differential		Fluid Temp.		Power	Voltage	Solenoid Valve Order Number
		Kv l/min	KV m³/h	Qn l/min			Min bar	Max bar	Min °C	Max °C			
1"	25	160	9.60	-	EPDM	-	0.1	10	-10	140	8	220-230V/50Hz	550029DIS
							0.1	10	-10	140	9	24 Vdc	550028DIS
							0.1	20	-10	90	8	220-230V/50Hz	550031DIS
							0.1	20	-10	90	9	24 Vdc	550030DIS
							0.1	20	-10	140	8	220-230V/50Hz	550204DIS
							0.1	20	-10	140	9	24 Vdc	550203DIS
					FKM	2-22	0.1	20	-10	50	8	220-230V/50Hz	550214DIS
							0.1	20	-10	50	9	24 Vdc	550213DIS
						1-21	0.1	20	-10	80	8	230V/50Hz	550206DIS
							0.1	20	-10	80	8	24 Vdc	550205DIS

⚡: Fast Delivery
ATEX

⚡: Fast Delivery

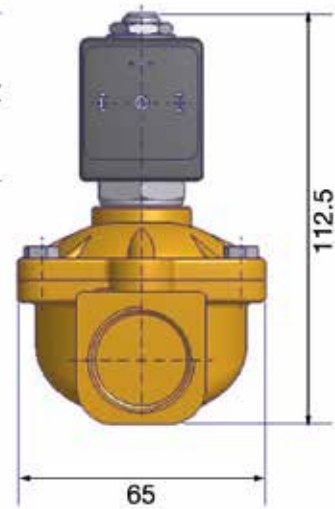
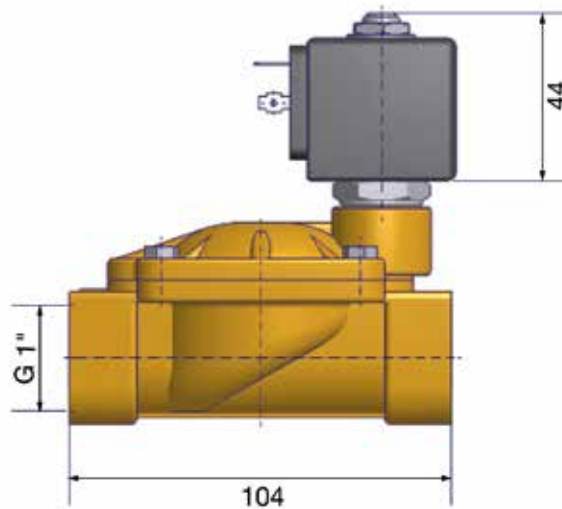
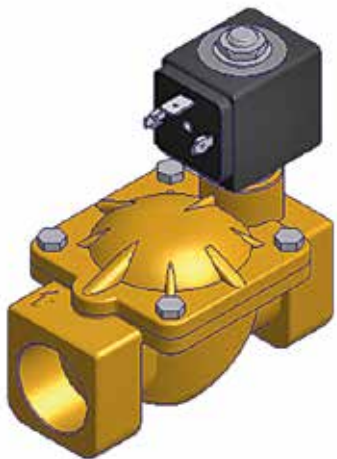

2 WAY VALVES

Water



2/2

VALVES FOR WATER PILOT OPERATED



BRASS PIPE MOUNTING

NORMALLY CLOSED

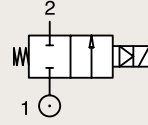

Port size	Orifice Ø	Flow factors			Seat Seal	Atex Zone	Operating Pressure Differential		Fluid Temp.		Power	Voltage	Solenoid Valve Order Number
		Kv l/min	KV m³/h	Qn l/min			Min bar	Max bar	Min °C	Max °C			
1 1/4"	35	420	25.20	-	EPDM	-	0.1	10	-10	140	8	220-230V/50Hz	550208DIS
							0.1	10	-10	140	9	24 Vdc	550207DIS
							0.1	10	-10	90	8	220-230V/50Hz	550033DIS
							0.1	10	-10	90	9	24 Vdc	550032DIS
1 1/2"	40	500	30.00	-	EPDM	-	0.1	10	-10	140	8	220-230V/50Hz	550210DIS
							0.1	10	-10	140	9	24 Vdc	550209DIS
							0.1	10	-10	90	8	220-230V/50Hz	550035DIS
							0.1	10	-10	90	9	24 Vdc	550034DIS
2"	50	620	37.20	-	EPDM	-	0.1	10	-10	140	8	220-230V/50Hz	550218DIS
							0.1	10	-10	140	9	24 Vdc	550217DIS
							0.1	10	-10	90	8	220-230V/50Hz	550216DIS
							0.1	10	-10	90	9	24 Vdc	550215DIS

Fast Delivery

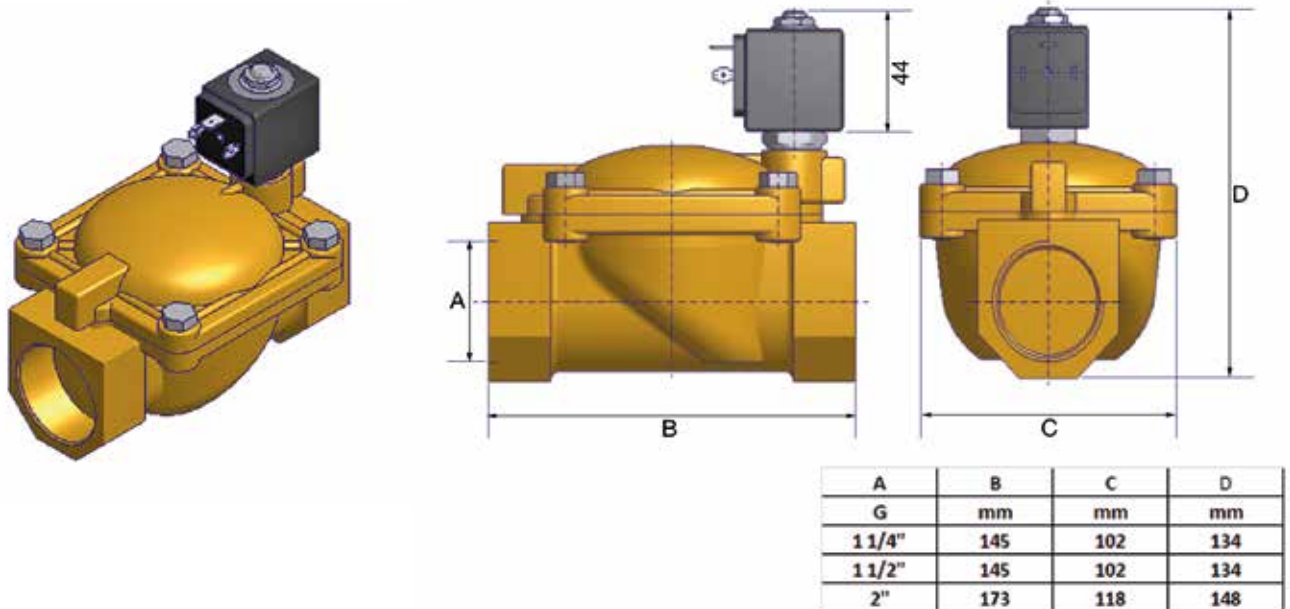

2/2

VALVES FOR WATER PILOT OPERATED

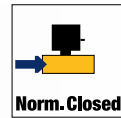

BRASS PIPE MOUNTING NORMALLY CLOSED

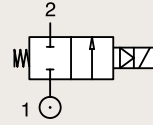

Port size	Orifice Ø	Flow factors			Seat Seal	Atex Zone	Operating Pressure Differential		Fluid Temp.		Power	Voltage	Solenoid Valve Order Number
		Kv l/min	KV m³/h	Qn l/min			Min bar	Max bar	Min °C	Max °C			
1/2"	13	50	3.00	-	NBR	-	0.1	20	-10	90	8	220-230V/50Hz	550023DIS
							0.1	20	-10	90	9	24 Vdc	550022DIS

Fast Delivery

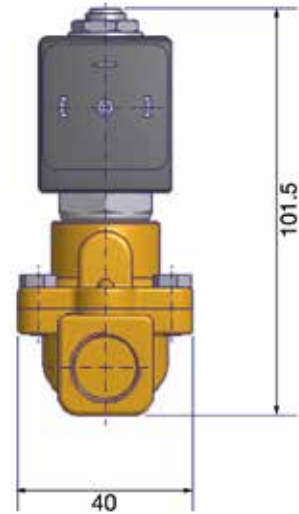
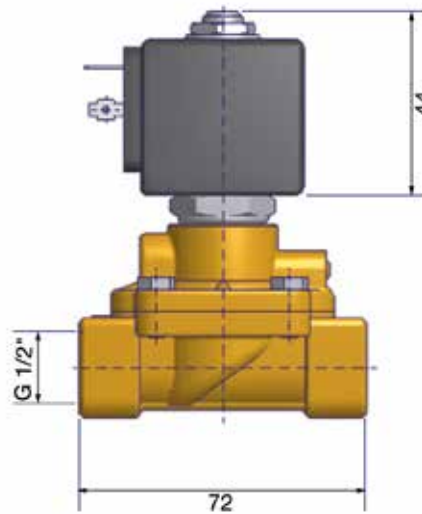
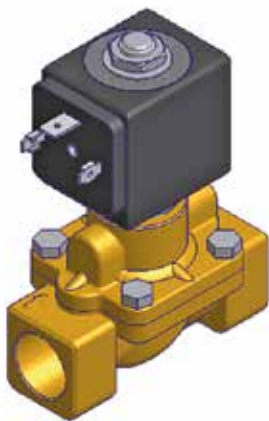

2 WAY VALVES

Water



2/2

VALVES FOR WATER PILOT OPERATED

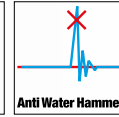
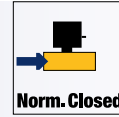

BRASS PIPE MOUNTING

NORMALLY CLOSED

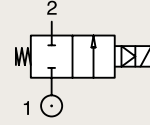

Port size	Orifice Ø	Flow factors			Seat Seal	Atex Zone	Operating Pressure Differential		Fluid Temp.		Power	Voltage	Solenoid Valve Order Number
		Kv l/min	KV m³/h	Qn l/min			Min bar	Max bar	Min °C	Max °C			
2 1/2"	65	1100	66.00	-	NBR	-	0.2	10	-10	90	8	220-230V/50Hz	550043DIS
							0.2	10	-10	90	9	24 Vdc	550042DIS
3"	75	1334	80.00	-	NBR	-	0.2	10	-10	90	8	220-230V/50Hz	550045DIS
							0.2	10	-10	90	9	24 Vdc	550044DIS

Fast Delivery

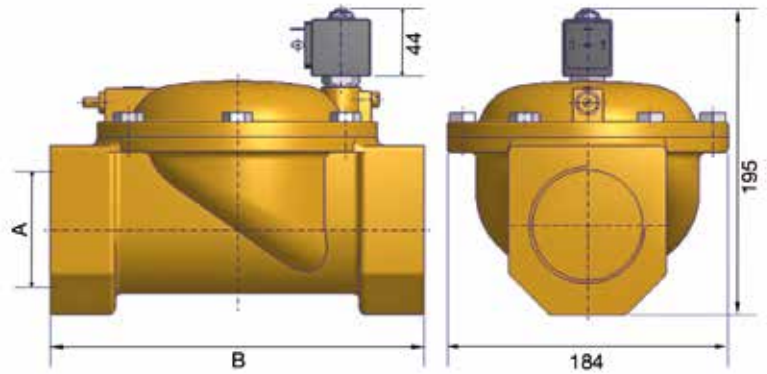
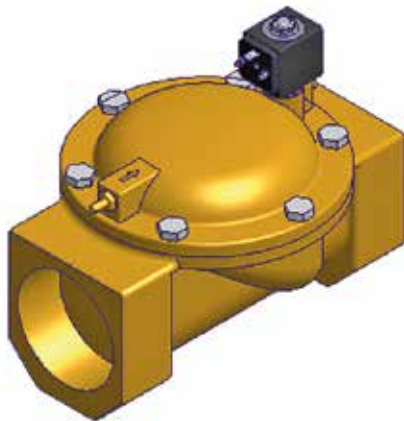

A	B
G	mm
2 1/2"	245
3"	250



2/2

VALVES FOR WATER PILOT OPERATED

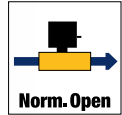

BRASS PIPE MOUNTING NORMALLY OPEN

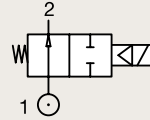

Port size	Orifice Ø	Flow factors			Seat Seal	Atex Zone	Operating Pressure Differential		Fluid Temp.		Power	Voltage	Solenoid Valve Order Number
		Kv l/min	KV m³/h	Qn l/min			Min bar	Max bar	Min °C	Max °C			
3/8"	13	50	3.00	-	NBR	-	0.1	20	-10	90	8	220-230V/50Hz	550057DIS
							0.1	20	-10	90	9	24 Vdc	550056DIS
						2-22	0.1	20	-10	50	8	220-230V/50Hz	550192DIS
							0.1	20	-10	50	9	24 Vdc	550191DIS
						1-21	0.1	20	-10	80	8	230V/50Hz	550152DIS
							0.1	20	-10	80	8	24 Vdc	550151DIS
1/2"	13	50	3.00	-	NBR	-	0.1	20	-10	90	8	220-230V/50Hz	550047DIS
							0.1	20	-10	90	9	24 Vdc	550046DIS
						2-22	0.1	20	-10	50	8	220-230V/50Hz	550182DIS
							0.1	20	-10	50	9	24 Vdc	550181DIS
						1-21	0.1	20	-10	80	8	230V/50Hz	550142DIS
							0.1	20	-10	80	8	24 Vdc	550141DIS

Fast Delivery

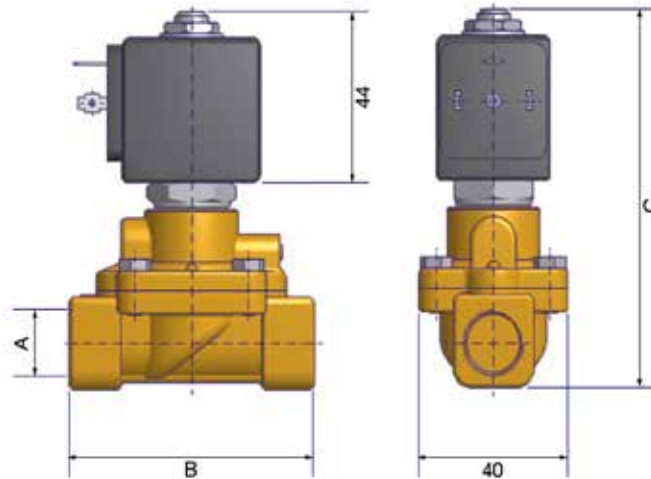
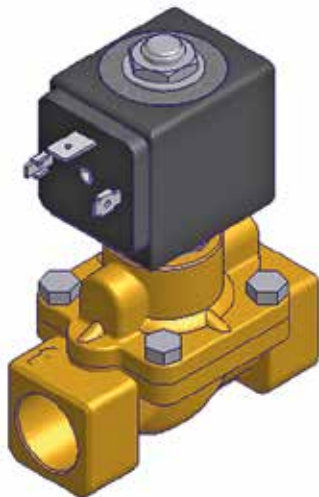

A	B	C
G	mm	mm
3/8"	69	99.5
1/2"	72	101.5

2 WAY VALVES

Water



2/2

VALVES FOR WATER PILOT OPERATED

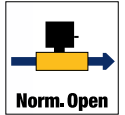

BRASS PIPE MOUNTING

NORMALLY OPEN

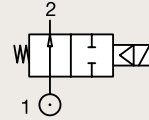

Port size	Orifice Ø	Flow factors			Seat Seal	Atex Zone	Operating Pressure Differential		Fluid Temp.		Power	Voltage	Solenoid Valve Order Number
		Kv l/min	KV m³/h	Qn l/min			Min bar	Max bar	Min °C	Max °C			
3/4"	20	140	8.40	-	NBR	-	0.1	20	-10	90	8	220-230V/50Hz	550049DIS
							0.1	20	-10	90	9	24 Vdc	550048DIS
							0.1	20	-10	50	8	220-230V/50Hz	550184DIS
							0.1	20	-10	50	9	24 Vdc	550183DIS
							0.1	20	-10	80	8	230V/50Hz	550144DIS
							0.1	20	-10	80	8	24 Vdc	550143DIS
1"	25	160	9.60	-	NBR	-	0.1	20	-10	90	8	220-230V/50Hz	550051DIS
							0.1	20	-10	90	9	24 Vdc	550050DIS
							0.1	20	-10	50	8	220-230V/50Hz	550186DIS
							0.1	20	-10	50	9	24 Vdc	550185DIS
							0.1	20	-10	80	8	230V/50Hz	550146DIS
							0.1	20	-10	80	8	24 Vdc	550145DIS

Fast Delivery

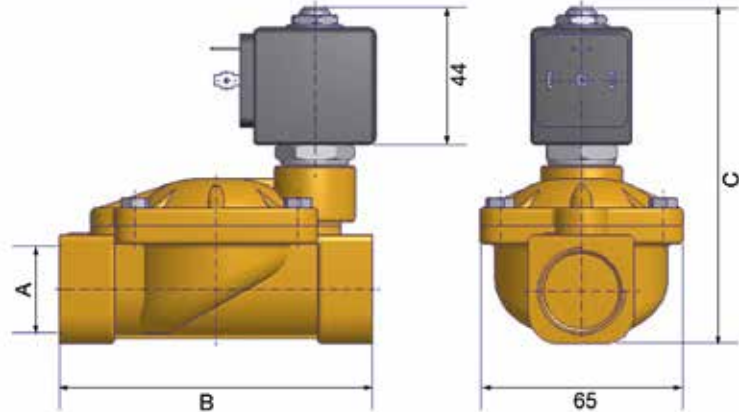
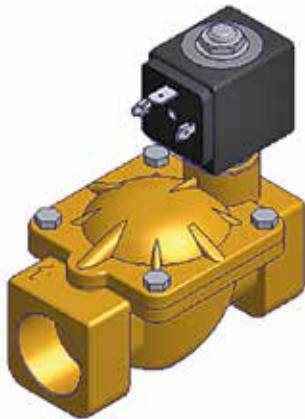

A	B	C
G	mm	mm
3/4"	100	107
1"	104	112.5



2/2

VALVES FOR WATER PILOT OPERATED

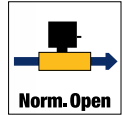

BRASS PIPE MOUNTING NORMALLY OPEN

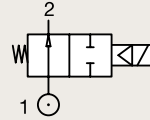

Port size	Orifice Ø	Flow factors			Seat Seal	Atex Zone	Operating Pressure Differential		Fluid Temp.		Power	Voltage	Solenoid Valve Order Number							
		Kv l/min	KV m³/h	Qn l/min			Min bar	Max bar	Min °C	Max °C				W						
1 1/2"	40	500	30.00	-	NBR	-	0.1	10	-10	90	8	220-230V/50Hz	550053DIS							
							0.1	10	-10	90	9	24 Vdc	550052DIS							
							2-22	0.1	10	-10	50	8	220-230V/50Hz	550188DIS						
								0.1	10	-10	50	9	24 Vdc	550187DIS						
							1-21	0.1	10	-10	80	8	230V/50Hz	550148DIS						
								0.1	10	-10	80	8	24 Vdc	550147DIS						
							2"	50	620	37.20	-	NBR	-	0.1	10	-10	90	8	220-230V/50Hz	550055DIS
														0.1	10	-10	90	9	24 Vdc	550054DIS
2-22	0.1	10	-10	50	8	220-230V/50Hz								550190DIS						
	0.1	10	-10	50	9	24 Vdc								550189DIS						
1-21	0.1	10	-10	80	8	230V/50Hz								550150DIS						
	0.1	10	-10	80	8	24 Vdc								550149DIS						

Fast Delivery

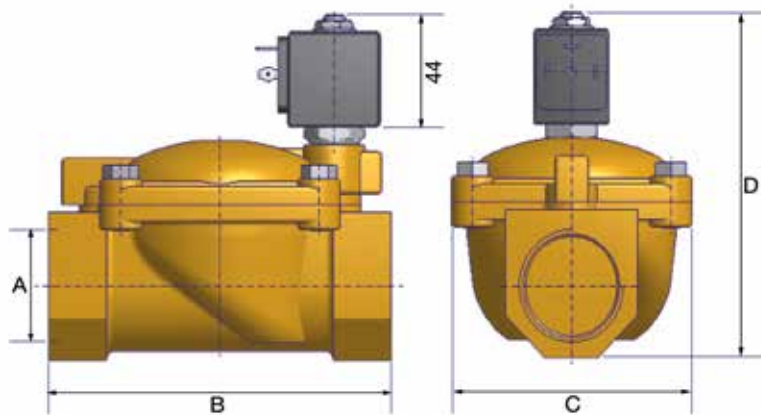
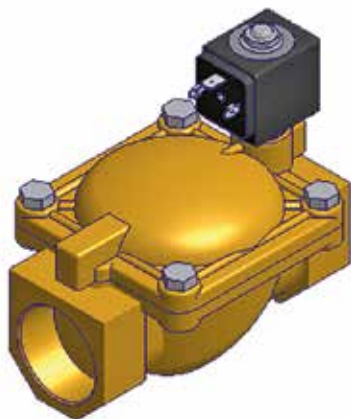

A	B	C	D
G	mm	mm	mm
1 1/2"	145	102	134
2"	173	118	148

2 WAY VALVES

Water





2/2

VALVES FOR HOT WATER AND STEAM



The Parker 2 way valves (1 way for inlet and 1 way for outlet) for steam and hot water are robust constructions for fluid temperature up to 180°C. This includes the famous Ruby seal and also the stainless steel bodies for the harshest requirements.

Typical applications are:

- Laundries
- Plastic molding
- Heating systems
- Sterilization

These applications can be found in many markets like industries, medical, process, etc...

Actuation	Body	Function	Specification	Port Size	Orifice (mm)	MOPD (bar)	Page
Direct Operated (No minimum pressure required)	Brass/ Pipe Mounting	Normally Closed	-	1/8" to 1/4"	2.5 to 3	6	54
	303 Stainless St./ Pipe Mounting	Normally Closed	-	1/4"	1.5 to 5	6	55
Pilot Operated (Minimum pressure required)	Brass/ Pipe Mounting	Normally Closed	-	3/8" to 1"	10 to 27	13	56
Magnalift(No minimum pressure - High flow)	Brass/ Pipe Mounting	Normally Closed	High Performance	3/8" to 1"	15	10	57

2/2

VALVES FOR HOT WATER AND STEAM DIRECT OPERATED



BRASS
PIPE MOUNTING

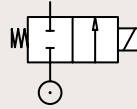

NORMALLY CLOSED

Port size	Orifice Ø	Flow factors			Seat Seal	Atex Zone	Operating Pressure Differential		Fluid Temp.		Power	Voltage	Solenoid Valve Order Number
		Kv l/min	KV m³/h	Qn l/min			Min bar	Max bar	Min °C	Max °C			
1/8"	2.5	3.2	0.20		Ruby	0	30	-30	140	9	230V/50-60Hz	550089DIS ₁	
						0	17	-30	140	12	24 Vdc	550088DIS ₁	
						0	30	-30	140	9	230V/50-60Hz	550085DIS ₁	
1/4"	3	4.2	0.25		PTFE	0	17	-30	140	12	24 Vdc	550084DIS ₁	
						0	10	-10	180	14	230V/50-60Hz	550221DIS ₂	
		4	0.24	Ruby	0	10	-10	180	16	24 Vdc	550222DIS ₂		
					0	30	-30	140	9	230V/50-60Hz	550087DIS ₂		
						0	17	-30	140	12	24 Vdc	550086DIS ₂	

Notes:

1. Drawing number 1
2. Drawing number 2

Fast Delivery

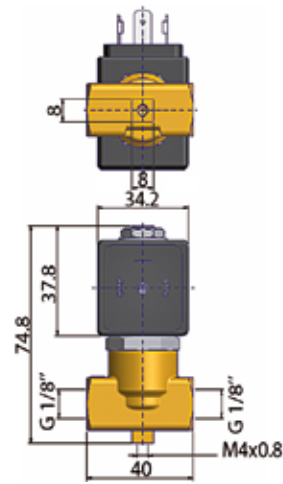

N° 1

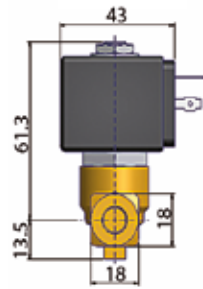

N° 2

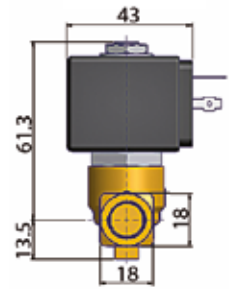
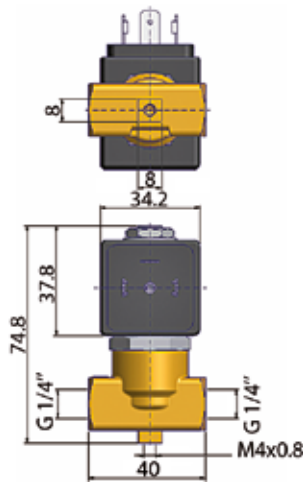

2/2

VALVES FOR HOT WATER AND STEAM DIRECT OPERATED

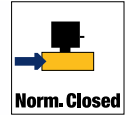

303 STAINLESS ST.
PIPE MOUNTING

NORMALLY CLOSED

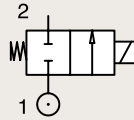

Port size	Orifice Ø	Flow factors			Seat Seal	Atex Zone	Operating Pressure Differential		Fluid Temp.		Power	Voltage	Solenoid Valve Order Number	
		Kv l/min	KV m³/h	Qn l/min			Min bar	Max bar	Min °C	Max °C				W
1/4"	1.5	1.5	0.09	80	Ruby	-	0	60	0	100	8	220-230V/50Hz	121V5463-2995-4818653D	
	3	4.5	0.27	315			0	25	0	140	9	24 Vdc	121V5463-2995-481865C2	
		5	10	0.60			750	0	20	0	100	8	220-230V/50Hz	121V5363-2995-4818653D
			7	0			100	9	24 Vdc	121V5363-2995-481865C2				
	8.5	0	100	8			220-230V/50Hz	121V5163-2995-4818653D						
2	0	100	9	24 Vdc	121V5163-2995-481865C2									

Fast Delivery

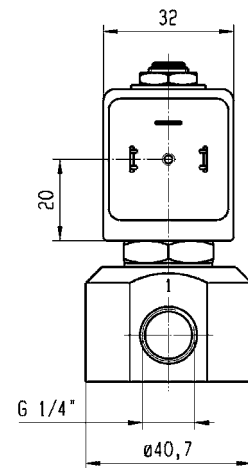
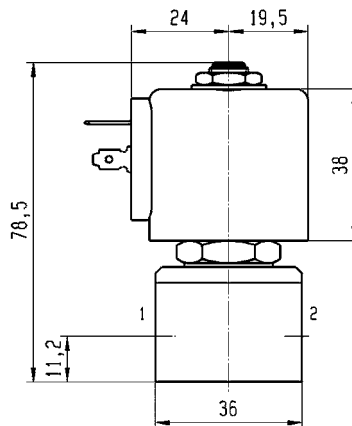
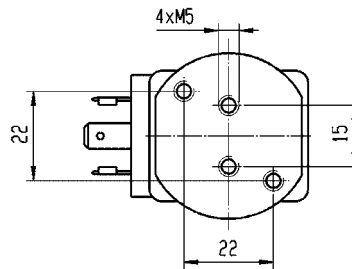

2 WAY VALVES

Hot Water & Steam



2/2

VALVES FOR HOT WATER AND STEAM PILOT OPERATED

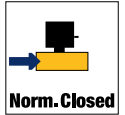

BRASS PIPE MOUNTING

NORMALLY CLOSED

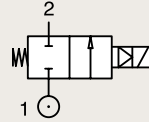

Port size	Orifice Ø	Flow factors			Seat Seal	Atex Zone	Operating Pressure Differential		Fluid Temp.		Power	Voltage	Solenoid Valve Order Number
		Kv l/min	KV m³/h	Qn l/min			Min bar	Max bar	Min °C	Max °C			
3/8"	10	22	1.32	-	PTFE	-	0.5	16	-30	160	9	230V/50-60Hz	550104DIS ₁
	16	78	4.70				0.5	10	-30	180	14	230V/50-60Hz	550077DIS ₂
1/2"	10	24	1.44				0.5	16	-30	160	9	230V/50-60Hz	550101DIS ₁
	16	78	4.70				0.5	10	-30	180	14	230V/50-60Hz	550072DIS ₂
3/4"	18	37	2.22				0.5	14	-30	160	9	230V/50-60Hz	550102DIS ₁
	27	193	11.60				0.5	10	-30	180	14	230V/50-60Hz	550074DIS ₂
1"	18	42	2.52				0.5	10	-30	180	16	24 Vdc	550073DIS ₂
							0.5	14	-30	160	9	230V/50-60Hz	550103DIS ₁
	27	193	11.60				0.5	10	-30	180	14	230V/50-60Hz	550076DIS ₂
							0.5	10	-30	180	16	24 Vdc	550075DIS ₂

Notes:

- Drawing number 1
- Drawing number 2

Fast Delivery

N° 1

A	B	C	D
G	mm	mm	mm
3/8"	48	85	40
1/2"	48	85	40
3/4"	48	85	40
1"	60	93.5	51

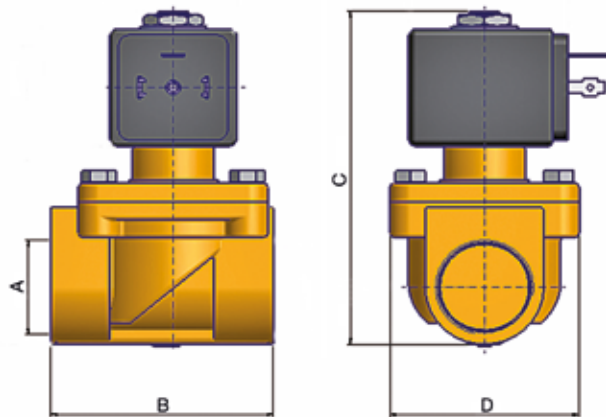

N° 2

A	B	C
G	mm	mm
3/8"	67	127
1/2"	67	127
3/4"	98.5	177
1"	98.5	177

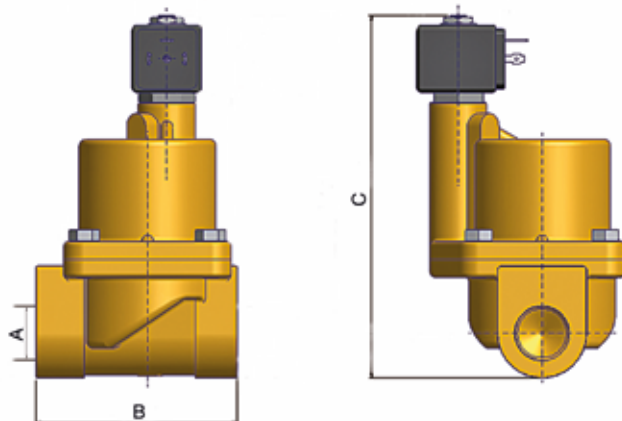

2/2

VALVES FOR HOT WATER AND STEAM MAGNALIFT

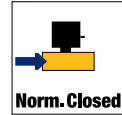

BRASS PIPE MOUNTING NORMALLY CLOSED

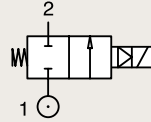

Port size	Orifice Ø	Flow factors			Seat Seal	Atex Zone	Operating Pressure Differential		Fluid Temp.		Power	Voltage	Solenoid Valve Order Number
		Kv l/min	KV m³/h	Qn l/min			Min bar	Max bar	Min °C	Max °C			
3/8"	15	65	3.90	-	EPDM	-	0	10	0	100	8	220-230V/50Hz	221G1303-2995-4818653D
1/2"							0	10	0	100	8	220-230V/50Hz	221G1503-2995-4818653D
3/4"		80	4.80				0	10	0	100	8	220-230V/50Hz	221G1603-2995-4818653D
1"							0	10	0	100	8	220-230V/50Hz	221G1703-2995-4818653D

Fast Delivery

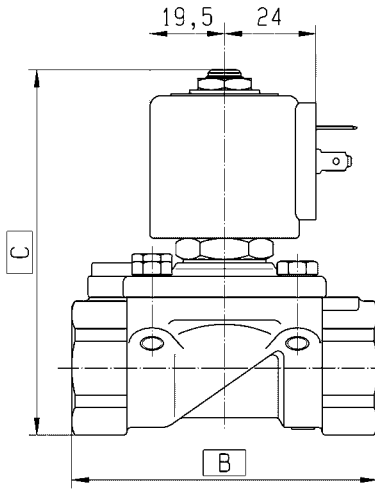
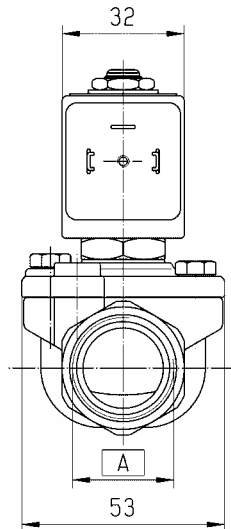

	A	B	C
G 3/8"	75	93	
G 1/2"	75	93	
G 3/4"	80	95,5	
G 1"	85	102,5	

2 WAY VALVES

Hot Water & Steam





3/2
5/2
3/2-5/2

VALVES FOR AIR



The Parker 3 way valves (1 way for inlet , 1 way for outlet and 1 way for exhaust) for air are typical constructions to pilot valve actuators or single acting cylinders applying or exhausting pressure in the chamber.

The Parker 5 ways valves (1 way for inlet, 2 ways for outlet and 2 ways for exhaust) for air are typical constructions to pilot double acting cylinders or valve actuators applying or exhausting pressure in the 2 chambers.

The high flow versions and the low response time allow improving installation efficiency.

Typical applications are:

- Piloting valves or cylinders
- Mixing

These applications can be found in many automation markets like industries, water treatment, process, etc...

Actuation	Body	Function	Specification	Port Size	Orifice (mm)	MOPD (bar)	Page
3/2 Direct Operated	Anodized Aluminium/ Banjo	Normally Closed	Manual override	1/8" to 1/4"	1.2	10	60
	Anodized Aluminium/ NAMUR	Normally Closed	Manual override	1/2"	12	10	61
			Compact / Manual override	1/2"	12	10	62
5/2 Pilot Operated	Anodized Aluminium/ Pipe Mounting	Spring Return	Compact / Manual override	1/4" to 1/2"	7 to 12	10	63
		Dual Solenoids	Compact / Manual override	1/4" to 1/2"	7 to 12	10	64
	Anodized Aluminium/ NAMUR	Spring Return	Manual override	1/2"	12	10	65
			Compact / Manual override	1/2"	12	10	66
		Dual Solenoids	Manual override	1/4" to 1/2"	7 to 12	10	67
			Compact / Manual override	1/4" to 1/2"	7 to 12	10	68
3/2-5/2 Pilot Operated	Anodized Aluminium/ NAMUR	Spring Return	Manual override	1/4"	7	10	69
			Compact / Manual override	1/4"	7	10	70

3 & 5 WAY VALVES

Air



3/2

VALVES FOR AIR DIRECT OPERATED

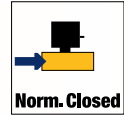

ANODIZED ALUMINIUM BANJO

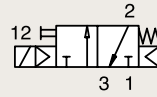

NORMALLY CLOSED

Port size	Orifice Ø	Flow factors	Seat Seal	Atex Zone	Operating Pressure Differential		Fluid Temp.		Power	Voltage	Solenoid Valve Order Number	
					Min bar	Max bar	Min °C	Max °C				W
BSP	mm	Qn l/min										
1/8"	1.2	50	NBR	-	0	10	-10	50	3	230V/50-60Hz	131B14-496131P9	
					0	10	-10	50	3	24 Vdc	131B14-496131C2	
					2-22	0	10	-10	50	3	230V/50-60Hz	131B14-496637P9
					0	10	-10	50	3	24 Vdc	131B14-496637C2	
1/4"	1.2	50	NBR	-	0	10	-10	50	3	230V/50-60Hz	131B04-496131P9	
					0	10	-10	50	3	24 Vdc	131B04-496131C2	
					2-22	0	10	-10	50	3	230V/50-60Hz	131B04-496637P9
					0	10	-10	50	3	24 Vdc	131B04-496637C2	
					1-21	0	10	-10	50	5	24 Vdc	131B14-482605C2
					1-21	0	10	-10	50	5	24 Vdc	131B04-482605C2

Notes:

Port size column is for the outlet connection size only. Inlet connection size is always 1/8"

Fast Delivery

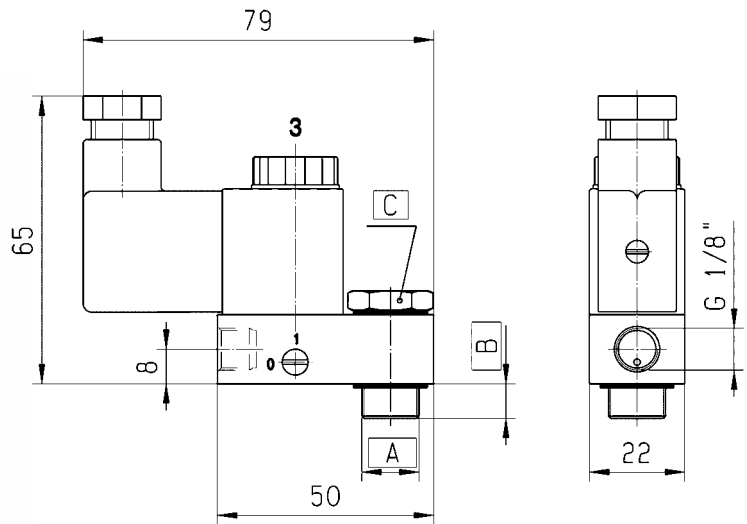

A	B	C
G 1/8"	6,2	SW 14
G 1/4"	8	SW 17



3/2

VALVES FOR AIR PILOT OPERATED



Manual Override

ANODIZED ALUMINIUM NAMUR

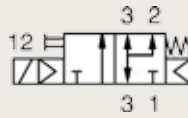

NORMALLY CLOSED

Port size	Orifice Ø	Flow factors	Seat Seal	Atex Zone	Operating Pressure Differential		Fluid Temp.		Power	Voltage	Solenoid Valve Order Number
					Min bar	Max bar	Min °C	Max °C			
1/2"	12	3000	NBR	-	2.5	10	-20	50	8	220-230V/50Hz	331N34-2995-4818653D ₁
					2.5	10	-20	50	9	24 Vdc	331N34-2995-481865C2 ₁
					2.5	10	-20	50	8	220-230V/50Hz	331N34-2995-4958703D ₁
					2.5	10	-20	50	9	24 Vdc	331N34-2995-495870C2 ₁
					2.5	10	-20	50	8	230V/50Hz	331N34-495905F4 ₁
					2.5	10	-20	50	8	24 Vdc	331N34-495905C2 ₁

Notes:

1. Pilot seat in FKM

Fast Delivery

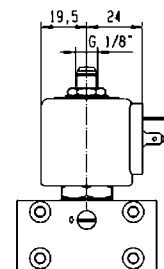
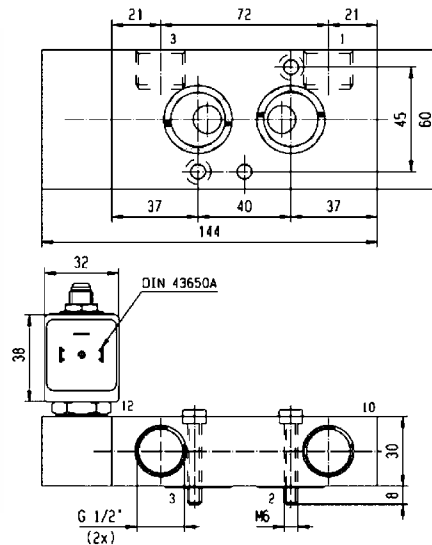

3 & 5 WAY VALVES

Air



3/2

VALVES FOR AIR PILOT OPERATED

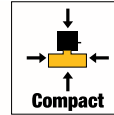

ANODIZED ALUMINIUM
NAMUR

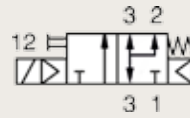

NORMALLY CLOSED

Port size	Orifice Ø	Flow factors	Seat Seal	Atex Zone	Operating Pressure Differential		Fluid Temp.		Power	Voltage	Solenoid Valve Order Number
					Min bar	Max bar	Min °C	Max °C			
BSP	mm	Qn l/min									
1/2"	12	3000	NBR	-	2	10	-20	50	3	230V/50-60Hz	331N04-496131P9
					2	10	-20	50	3	24 Vdc	331N04-496131C2
					2	10	-20	50	3	230V/50-60Hz	331N04-496637P9
					2	10	-20	50	3	24 Vdc	331N04-496637C2

Fast Delivery

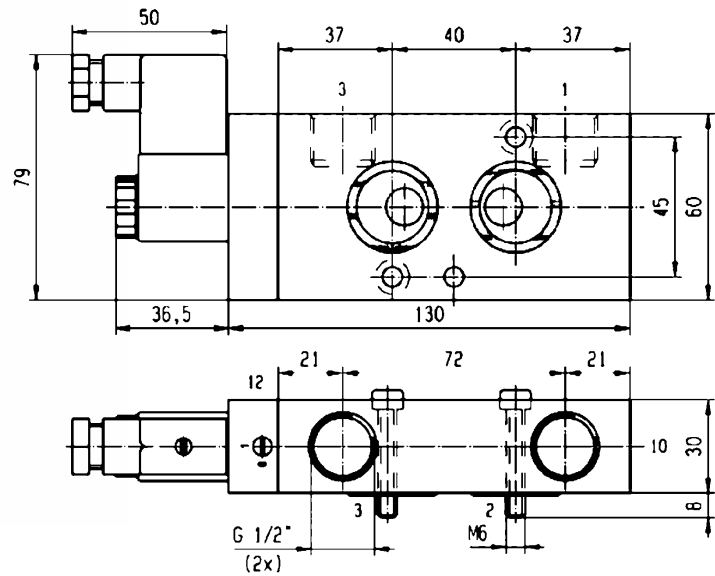

5/2

VALVES FOR AIR PILOT OPERATED

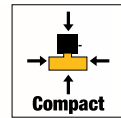

ANODIZED ALUMINIUM
PIPE MOUNTING

SPRING RETURN

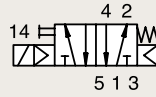

Port size	Orifice Ø	Flow factors	Seat Seal	Atex Zone	Operating Pressure Differential		Fluid Temp.		Power	Voltage	Solenoid Valve Order Number	
					Min bar	Max bar	Min °C	Max °C				W
1/4"	7	1250	NBR	-	2-22	2.5	10	-20	50	3	230V/50-60Hz	341P03-496131P9
						2.5	10	-20	50	3	24 Vdc	341P03-496131C2
					-	2.5	10	-20	50	3	230V/50-60Hz	341P03-496637P9
						2.5	10	-20	50	3	24 Vdc	341P03-496637C2
1/2"	12	3000	NBR	-	2-22	2.5	10	-20	50	3	230V/50-60Hz	341P04-496131P9
						2.5	10	-20	50	3	24 Vdc	341P04-496131C2
					-	2.5	10	-20	50	3	230V/50-60Hz	341P04-496637P9
						2.5	10	-20	50	3	24 Vdc	341P04-496637C2

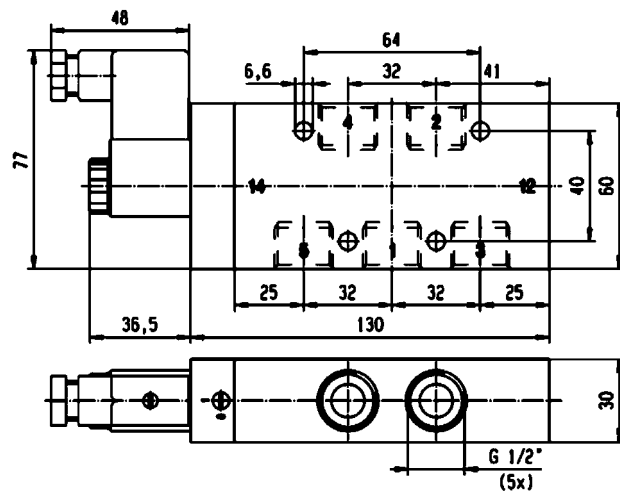
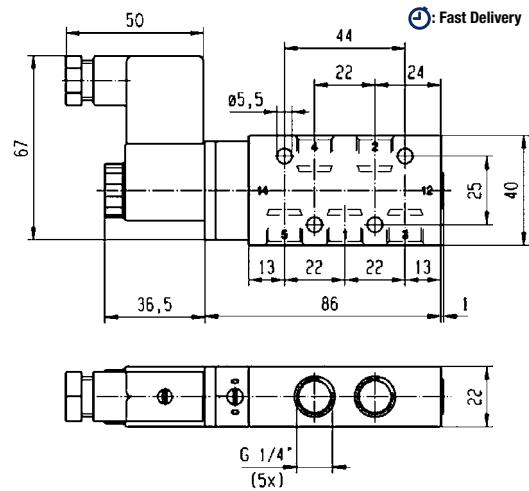

3 & 5 WAY VALVES

Air



5/2

VALVES FOR AIR PILOT OPERATED

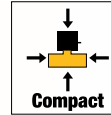

ANODIZED ALUMINIUM PIPE MOUNTING

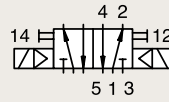

DUAL SOLENOIDS

Port size	Orifice Ø	Flow factors	Seat Seal	Atex Zone	Operating Pressure Differential		Fluid Temp.		Power	Voltage	Solenoid Valve Order Number	
					Min bar	Max bar	Min °C	Max °C				W
1/4"	7	1250	NBR	-	2.5	10	-20	50	3	230V/50-60Hz	347P03-496131P9	
											24 Vdc	347P03-496131C2
					2-22	2.5	10	-20	50	3	230V/50-60Hz	347P03-496637P9
												24 Vdc
1/2"	12	3000	NBR	-	2.5	10	-20	50	3	230V/50-60Hz	347P04-496131P9	
											24 Vdc	347P04-496131C2
					2-22	2.5	10	-20	50	3	230V/50-60Hz	347P04-496637P9
												24 Vdc

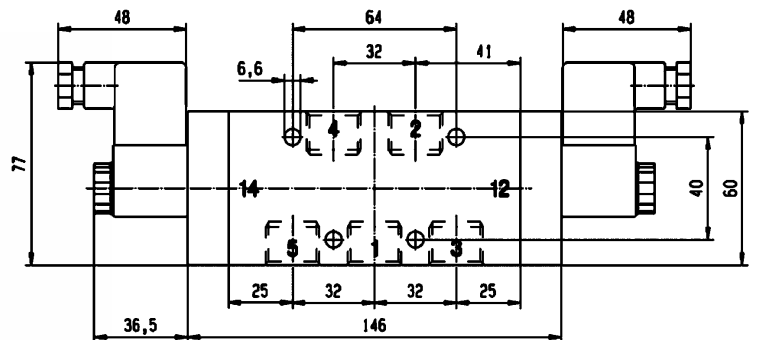
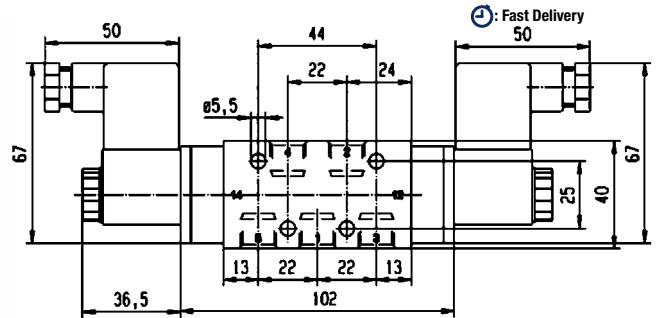

5/2

VALVES FOR AIR PILOT OPERATED



Manual Override

ANODIZED ALUMINIUM NAMUR

SPRING RETURN

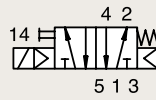

Port size	Orifice Ø	Flow factors	Seat Seal	Atex Zone	Operating Pressure Differential		Fluid Temp.		Power	Voltage	Solenoid Valve Order Number
					Min bar	Max bar	Min °C	Max °C			
1/2"	12	3000	NBR	-	2.5	10	-20	50	8	220-230V/50Hz	341N34-2995-4818653D ₁
					2.5	10	-20	50	9	24 Vdc	341N34-2995-481865C2 ₁
					2.5	10	-20	50	8	220-230V/50Hz	341N34-2995-4958703D ₁
					2.5	10	-20	50	9	24 Vdc	341N34-2995-495870C2 ₁
					2.5	10	-20	50	8	230V/50Hz	341N34-495905F4 ₁
					2.5	10	-20	50	8	24 Vdc	341N34-495905C2 ₁

Notes:

1. Pilot seat in FKM

Fast Delivery

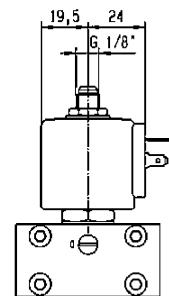
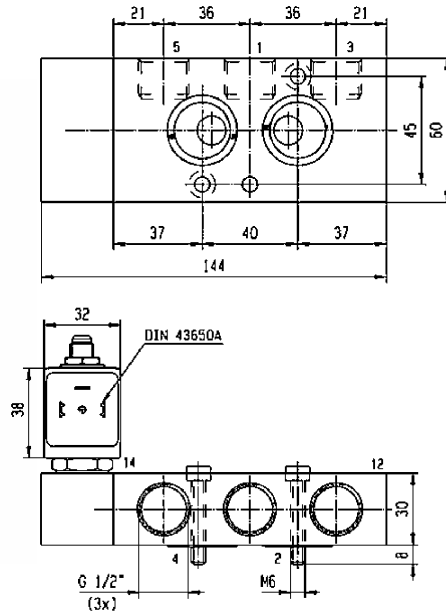

3 & 5 WAY VALVES

Air



5/2

VALVES FOR AIR PILOT OPERATED

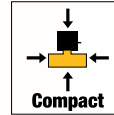

ANODIZED ALUMINIUM
NAMUR

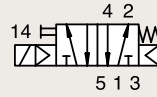

SPRING RETURN

Port size	Orifice Ø	Flow factors	Seat Seal	Atex Zone	Operating Pressure Differential		Fluid Temp.		Power	Voltage	Solenoid Valve Order Number
					Min bar	Max bar	Min °C	Max °C			
BSP	mm	Qn l/min									
1/2"	12	3000	NBR	-	2	10	-20	50	3	230V/50-60Hz	341N04-496131P9
					2	10	-20	50	3	24 Vdc	341N04-496131C2
					2	10	-20	50	3	230V/50-60Hz	341N04-496637P9
					2	10	-20	50	3	24 Vdc	341N04-496637C2

Fast Delivery

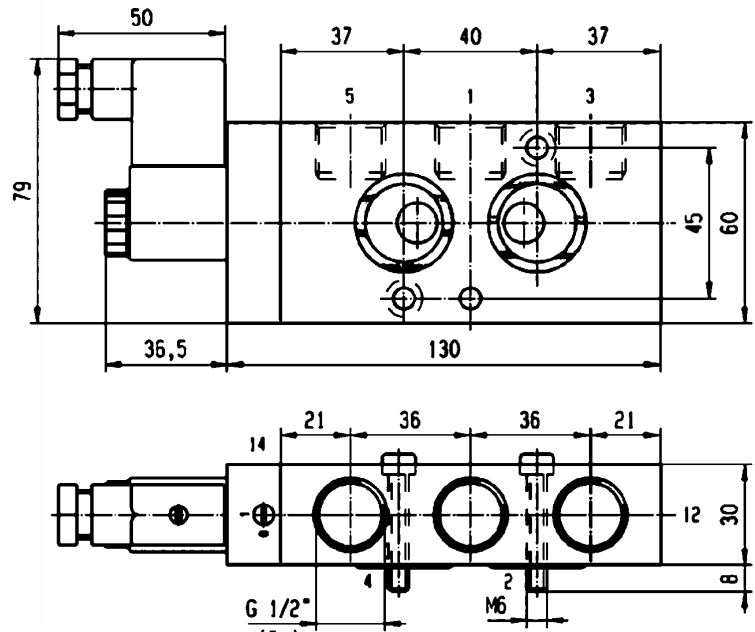

5/2

VALVES FOR AIR PILOT OPERATED



Manual Override

ANODIZED ALUMINIUM NAMUR

DUAL SOLENOIDS

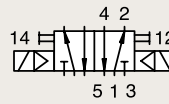

Port size	Orifice Ø	Flow factors	Seat Seal	Atex Zone	Operating Pressure Differential		Fluid Temp.		Power	Voltage	Solenoid Valve Order Number	
					Min bar	Max bar	Min °C	Max °C				W
1/4"	7	1250	NBR	-	2.5	10	-20	50	8	220-230V/50Hz	347N33-2995-4818653D	
					2.5	10	-20	50	9	24 Vdc	347N33-2995-481865C2	
					2-22	2.5	10	-20	50	8	220-230V/50Hz	347N33-2995-4958703D
					2-22	2.5	10	-20	50	9	24 Vdc	347N33-2995-495870C2
					1-21	2.5	10	-20	50	8	230V/50Hz	347N33-495905F4
					1-21	2.5	10	-20	50	8	24 Vdc	347N33-495905C2
1/2"	12	3000	NBR	-	2.5	10	-20	50	8	220-230V/50Hz	347N34-2995-4818653D	
					2.5	10	-20	50	9	24 Vdc	347N34-2995-481865C2	
					2-22	2.5	10	-20	50	8	220-230V/50Hz	347N34-2995-4958703D
					2-22	2.5	10	-20	50	9	24 Vdc	347N34-2995-495870C2
					1-21	2.5	10	-20	50	8	230V/50Hz	347N34-495905F4
					1-21	2.5	10	-20	50	8	24 Vdc	347N34-495905C2

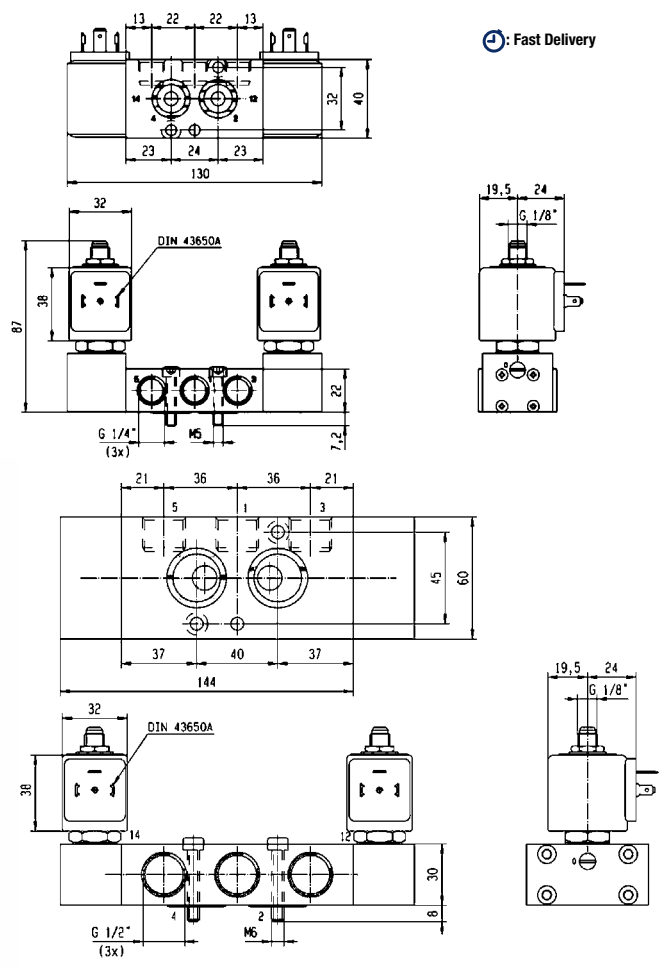

Fast Delivery

3 & 5 WAY VALVES
Air



5/2

VALVES FOR AIR PILOT OPERATED

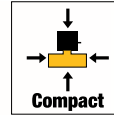

ANODIZED ALUMINIUM
NAMUR

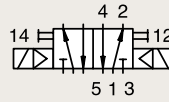

DUAL SOLENOIDS

Port size	Orifice Ø	Flow factors	Seat Seal	Atex Zone	Operating Pressure Differential		Fluid Temp.		Power	Voltage	Solenoid Valve Order Number	
					Min bar	Max bar	Min °C	Max °C				W
BSP	mm	Qn l/min										
1/4"	7	1250	NBR	-	2.5	10	-20	50	3	230V/50-60Hz	347N03-496131P9	
					2.5	10	-20	50	3	24 Vdc	347N03-496131C2	
					2-22	2.5	10	-20	50	3	230V/50-60Hz	347N03-496637P9
					2-22	2.5	10	-20	50	3	24 Vdc	347N03-496637C2
1/2"	12	3000		-	2.5	10	-20	50	3	230V/50-60Hz	347N04-496131P9	
					2.5	10	-20	50	3	24 Vdc	347N04-496131C2	
					2-22	2.5	10	-20	50	3	230V/50-60Hz	347N04-496637P9
					2-22	2.5	10	-20	50	3	24 Vdc	347N04-496637C2

Fast Delivery

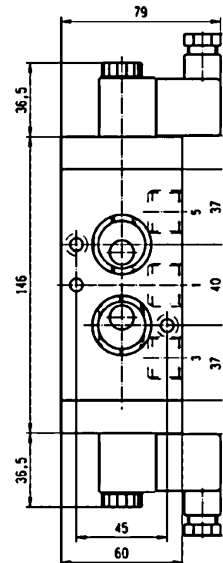
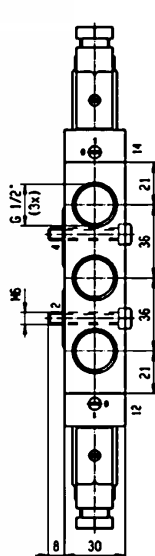
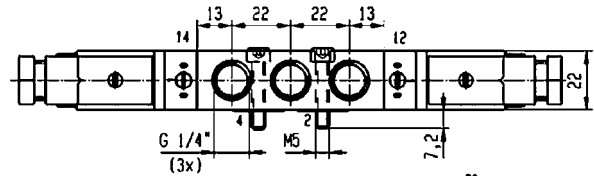
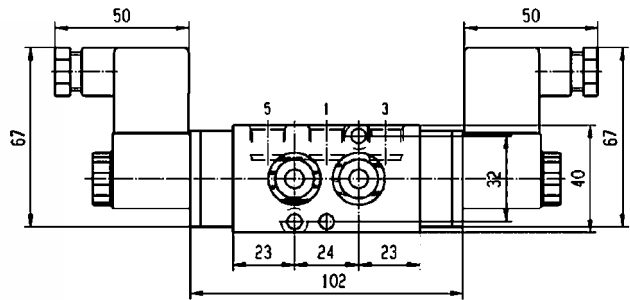

3/2-5/2

VALVES FOR AIR PILOT OPERATED



ANODIZED ALUMINIUM
NAMUR

SPRING RETURN

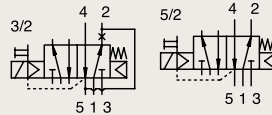

Port size	Orifice Ø	Flow factors	Seat Seal	Atex Zone	Operating Pressure Differential		Fluid Temp.		Power	Voltage	Solenoid Valve Order Number
					Min bar	Max bar	Min °C	Max °C			
1/4"	7	1250	NBR	-	2.5	10	-20	50	8	220-230V/50Hz	341N35-2995-4818653D ₁
					2.5	10	-20	50	9	24 Vdc	341N35-2995-481865C2 ₁
					2.5	10	-20	50	8	220-230V/50Hz	341N35-2995-4958703D ₁
					2.5	10	-20	50	9	24 Vdc	341N35-2995-495870C2 ₁
					2.5	10	-20	50	8	230V/50Hz	341N35-495905F4 ₁
					2.5	10	-20	50	8	24 Vdc	341N35-495905C2 ₁

Notes:
1. Pilot seat in FKM

Fast Delivery

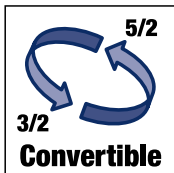
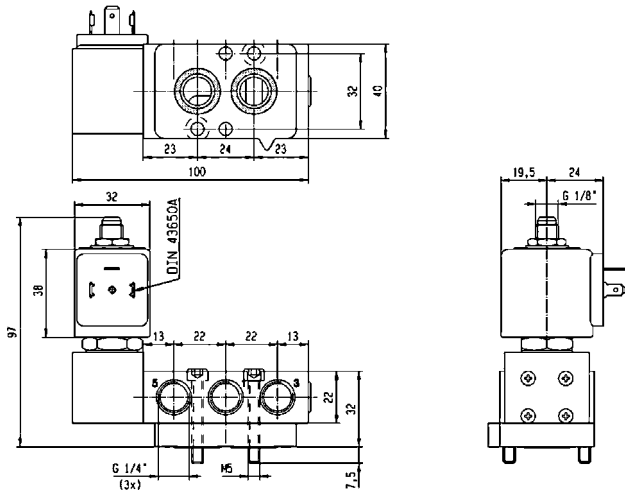

Original PARKER patented interface conversion plate permits to convert 3/2 to 5/2 function



3 & 5 WAY VALVES
Air



3/2-5/2

VALVES FOR AIR PILOT OPERATED

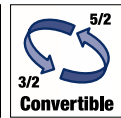
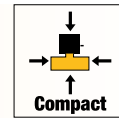

ANODIZED ALUMINIUM
NAMUR

SPRING RETURN

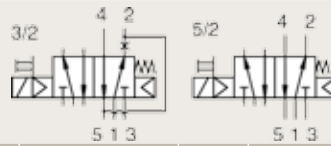

Port size	Orifice Ø	Flow factors	Seat Seal	Atex Zone	Operating Pressure Differential		Fluid Temp.		Power	Voltage	Solenoid Valve Order Number
					Min bar	Max bar	Min °C	Max °C			
BSP	mm	Qn l/min									
1/4"	7	1250	NBR	-	2.5	10	-20	50	3	230V/50-60Hz	341N05-496131P9
					2.5	10	-20	50	3	24 Vdc	341N05-496131C2
					2.5	10	-20	50	3	230V/50-60Hz	341N05-496637P9
					2.5	10	-20	50	3	24 Vdc	341N05-496637C2

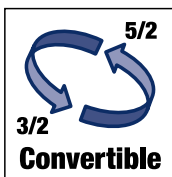
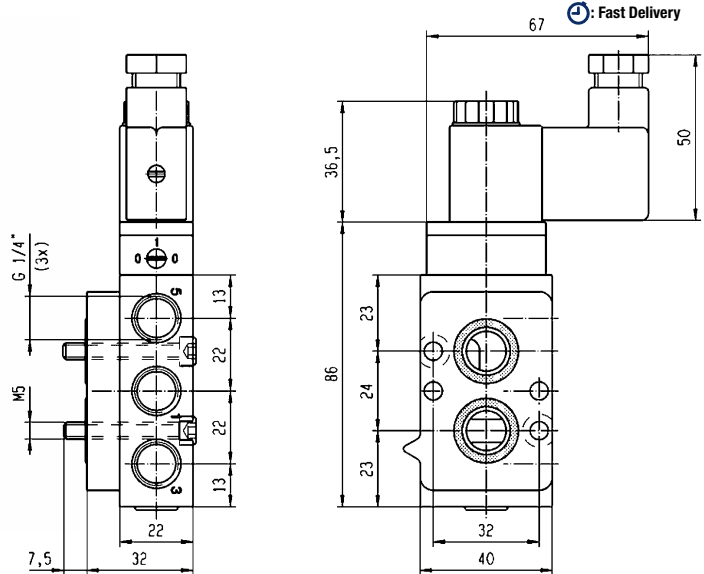

Original PARKER patented interface conversion plate permits to convert 3/2 to 5/2 function



3/2 VALVES FOR ALL FLUIDS AND AIR



The Parker 3 way valves (1 way for inlet, 1 way for outlet and 1 way for exhaust) for all fluids, including air, are typical constructions to control fluids for mixing or to pilot operators with other fluids than air.

The different sealing solutions give a large range of chemical compatibility. These applications can be found in many automation markets like industries, water treatment, process, etc...

Actuation	Body	Function	Specification	Port Size	Orifice (mm)	MOPD (bar)	Page
3/2 Direct Operated (No minimum pressure required)	Brass/ Pipe Mounting	Normally Closed	-	1/8" to 1/4"	1.2 to 2.5	16	72
			Manual override	1/8" to 1/4"	1.5 to 2.5	15	75
			3 ways in the body	1/4"	2 to 4.5	10	76
			3 ways in the body / Manual override	1/4"	2	10	77
		Normally Open	-	1/4"	2 to 2.5	10	78
		Universal	-	1/4"	0.8 to 3.5	30	79
			3 ways in the body	1/4"	2	7	82
			3 ways in the body / Manual override	1/4"	2	7	83
	303 Stainless St./ Pipe Mounting		Normally Closed	-	1/4"	2.5	7
		Universal	-	1/4"	1.5	10	85
	316L Stainless St./ Pipe Mounting	Normally Closed	-	1/8" to 1/4"	1.5	8	86

3/2

VALVES FOR ALL FLUIDS AND AIR DIRECT OPERATED

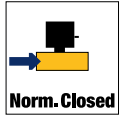

BRASS PIPE MOUNTING

NORMALLY CLOSED

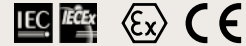
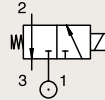

Port size	Orifice Ø	Flow factors			Seat Seal	Atex Zone	Operating Pressure Differential		Fluid Temp.		Power	Voltage	Solenoid Valve Order Number	
		1 Kv l/min	(2) Kv l/min	1 KV m³/h			(2) KV m³/h	Qn l/min	Min bar	Max bar				Min °C
1/8"	1.2	0.7	0.9	0.05	50	FKM	-	0	10	-10	75	2	220-230V/50Hz	131M15-8993-4889803D ₁
							-	0	10	-10	75	2.5	24 Vdc	131M15-8993-488980C2 ₁
							2-22	0	10	-10	50	2	220-230V/50Hz	131M15-8993-4958653D ₁
							2-22	0	10	-10	50	2.5	24 Vdc	131M15-8993-495865C2 ₁
							1-21	0	10	-10	65	2	220-230V/50Hz	131M15-4826063D ₁
							1-21	0	10	-10	65	2.5	24 Vdc	131M15-482606C2 ₁
	-	0	14	-10	140		4.5	230V/50-60Hz	550063DIS ₂					
	-	0	14	-10	140		5	24 Vdc	550220DIS ₂					
	-	0	7	-10	75		2	220-230V/50Hz	131M14-8993-4889803D ₁					
	-	0	7	-10	75		2.5	24 Vdc	131M14-8993-488980C2 ₁					
	-	0	7	-10	50		2	220-230V/50Hz	131M14-8993-4958653D ₁					
	-	0	7	-10	50		2.5	24 Vdc	131M14-8993-495865C2 ₁					
-	0	7	-10	65	2	220-230V/50Hz	131M14-4826063D ₁							
-	0	7	-10	65	2.5	24 Vdc	131M14-482606C2 ₁							
-	0	8	-10	140	4.5	230V/50-60Hz	550062DIS ₂							
-	0	8	-10	140	5	24 Vdc	550219DIS ₂							

Notes:

1. Drawing n°1
2. Drawing n°2

n°1



n°2

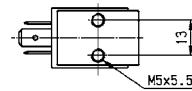
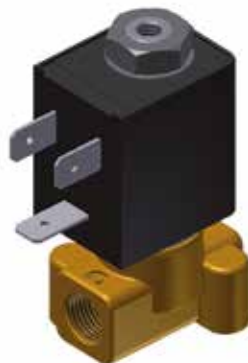

Fast Delivery

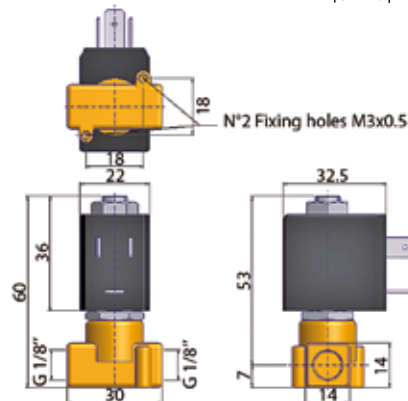
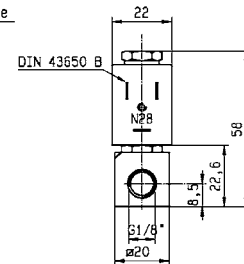
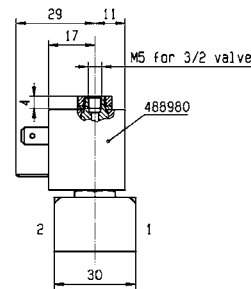

3/2

VALVES FOR ALL FLUIDS AND AIR DIRECT OPERATED

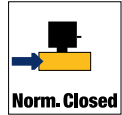

BRASS PIPE MOUNTING NORMALLY CLOSED

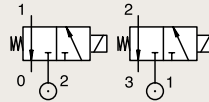

Port size	Orifice Ø	Flow factors				Seat Seal	Atex Zone	Operating Pressure Differential		Fluid Temp.		Power W	Voltage	Solenoid Valve Order Number		
		1 Kv l/min	(2) Kv l/min	1 KV m³/h	(2) KV m³/h			Qn l/min	Min bar	Max bar	Min °C				Max °C	
1/8"	2.5	3.5	3.5	0.21	0.21	220	FKM	-	0	7	-10	100	8	220-230V/50Hz	E131K13-2995-4818653D	ATEX
								-	0	7	-10	100	9	24 Vdc	E131K13-2995-481865C2	
								2-22	0	7	-10	65	8	220-230V/50Hz	E131K13-2995-4958703D	ATEX
								2-22	0	7	-10	65	9	24 Vdc	E131K13-2995-495870C2	
								1-21	0	7	-10	80	8	230V/50Hz	E131K13-495905F4	ATEX
								1-21	0	7	-10	80	8	24 Vdc	E131K13-495905C2	
1/4"	1.5	1.5	1.5	0.09	0.09	80		-	0	16	-10	120	8	220-230V/50Hz	E131K04-2995-4818653D	ATEX
								-	0	16	-10	120	9	24 Vdc	E131K04-2995-481865C2	
								2-22	0	16	-10	65	8	220-230V/50Hz	E131K04-2995-4958703D	ATEX
								2-22	0	16	-10	65	9	24 Vdc	E131K04-2995-495870C2	
								1-21	0	16	-10	80	8	230V/50Hz	E131K04-495905F4	ATEX
								1-21	0	16	-10	80	8	24 Vdc	E131K04-495905C2	
	2	2.5	3.5	0.15	0.21	140	-	0	10	-10	100	8	220-230V/50Hz	E131K06-2995-4818653D	ATEX	
							-	0	10	-10	100	9	24 Vdc	E131K06-2995-481865C2		
							2-22	0	10	-10	65	8	220-230V/50Hz	E131K06-2995-4958703D	ATEX	
							2-22	0	10	-10	65	9	24 Vdc	E131K06-2995-495870C2		
							1-21	0	10	-10	80	8	230V/50Hz	E131K06-495905F4	ATEX	
							1-21	0	10	-10	80	8	24 Vdc	E131K06-495905C2		

Fast Delivery

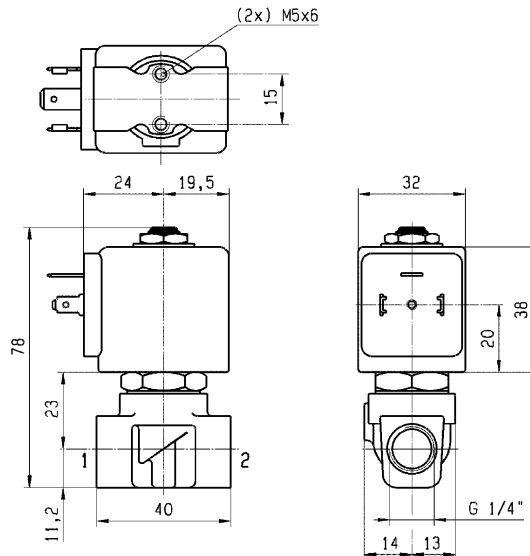

3 & 5 WAY VALVES

All Fluids & Air



3/2

VALVES FOR ALL FLUIDS AND AIR DIRECT OPERATED

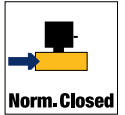

BRASS PIPE MOUNTING NORMALLY CLOSED

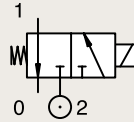

Port size	Orifice Ø	Flow factors				Seat Seal	Atex Zone	Operating Pressure Differential		Fluid Temp.		Power W	Voltage	Solenoid Valve Order Number
		1 Kv l/min	(2) Kv l/min	1 Kv m³/h	(2) Kv m³/h			Qn l/min	Min bar	Max bar	Min °C			
BSP	2	2	2.8	0.12	0.17	-	-	0	15	-10	140	9	230V/50-60Hz	550090DIS
								0	7	-10	120	8	220-230V/50Hz	E131K03-2995-4818653D
1/4"	2.5	3.5	3.5	0.21	0.21	220	FKM	0	7	-10	120	9	24 Vdc	E131K03-2995-481865C2
								0	7	-10	65	8	220-230V/50Hz	E131K03-2995-4958703D
								0	7	-10	65	9	24 Vdc	E131K03-2995-495870C2
								0	7	-10	80	8	230V/50Hz	E131K03-495905F4
								0	7	-10	80	8	24 Vdc	E131K03-495905C2
								0	7	-10	80	8	24 Vdc	E131K03-495905C2

Fast Delivery

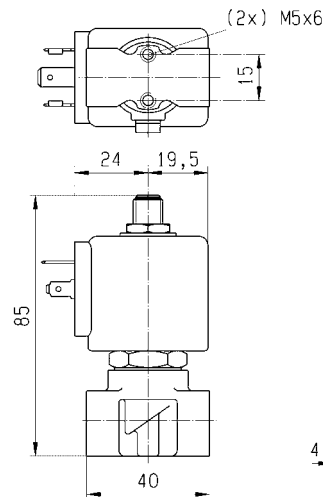
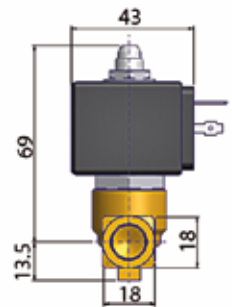
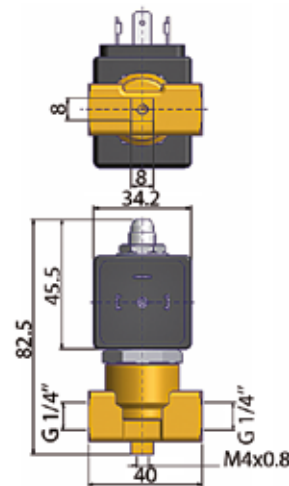

3/2

VALVES FOR ALL FLUIDS AND AIR DIRECT OPERATED

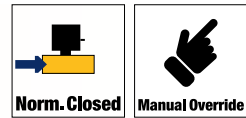

BRASS PIPE MOUNTING

NORMALLY CLOSED

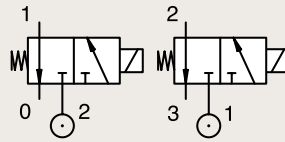

Port size	Orifice Ø	Flow factors				Seat Seal	Atex Zone	Operating Pressure Differential		Fluid Temp.		Power W	Voltage	Solenoid Valve Order Number
		1 Kv l/min	(2) Kv l/min	1 KV m³/h	(2) KV m³/h			Min bar	Max bar	Min °C	Max °C			
1/8"	2	2.5	3.5	0.15	0.21	140	FKM	0	10	-10	100	8	220-230V/50Hz	131K1650-2995-4818653D
								0	10	-10	100	9	24 Vdc	131K1650-2995-481865C2
								0	10	-10	65	8	220-230V/50Hz	131K1650-2995-4958703D
								0	10	-10	65	9	24 Vdc	131K1650-2995-495870C2
		1-21	0	10	-10	80		8	230V/50Hz	131K1650-495905F4				
			0	10	-10	80		8	24 Vdc	131K1650-495905C2				
			0	15	-10	100		8	220-230V/50Hz	E131K0450-2995-4818653D				
			0	15	-10	100		9	24 Vdc	E131K0450-2995-481865C2				
1/4"	2	1.5	1.5	0.09	0.09	80	FKM	0	15	-10	65	8	220-230V/50Hz	E131K0450-2995-4958703D
								0	15	-10	65	9	24 Vdc	E131K0450-2995-495870C2
								0	15	-10	80	8	230V/50Hz	E131K0450-495905F4
								0	15	-10	80	8	24 Vdc	E131K0450-495905C2
		1-21	0	10	-10			100	8	220-230V/50Hz	E131K0650-2995-4818653D			
			0	10	-10			100	9	24 Vdc	E131K0650-2995-481865C2			
			0	10	-10			65	8	220-230V/50Hz	E131K0650-2995-4958703D			
			0	10	-10			65	9	24 Vdc	E131K0650-2995-495870C2			
1/4"	2	2.5	0.15	0.21	140	FKM	FKM	0	10	-10	80	8	230V/50Hz	E131K0650-495905F4
								0	10	-10	80	8	24 Vdc	E131K0650-495905C2
								0	7	-10	100	8	220-230V/50Hz	E131K0350-2995-4818653D
								0	7	-10	100	9	24 Vdc	E131K0350-2995-481865C2
		1-21	0	7				-10	65	8	220-230V/50Hz	E131K0350-2995-4958703D		
			0	7				-10	65	9	24 Vdc	E131K0350-2995-495870C2		
			0	7				-10	80	8	230V/50Hz	E131K0350-495905F4		
			0	7				-10	80	8	24 Vdc	E131K0350-495905C2		

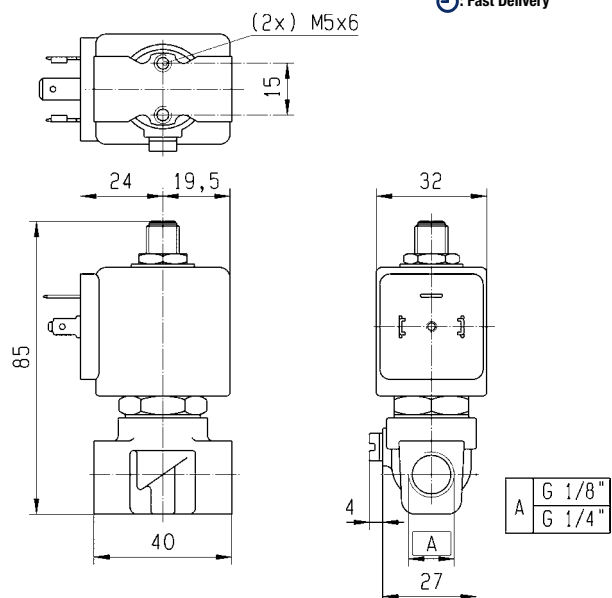

Fast Delivery

3 & 5 WAY VALVES

All Fluids & Air



3/2

VALVES FOR ALL FLUIDS AND AIR DIRECT OPERATED

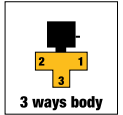
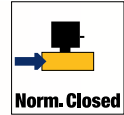

BRASS
PIPE MOUNTING

NORMALLY CLOSED

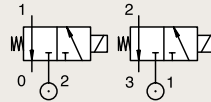

Port size	Orifice Ø	Flow factors				Seat Seal	Atex Zone	Operating Pressure Differential		Fluid Temp.		Power	Voltage	Solenoid Valve Order Number	
		1 Kv l/min	(2) Kv l/min	1 KV m³/h	(2) KV m³/h			Qn l/min	Min bar	Max bar	Min °C				Max °C
1/4"	2	2.5	4.5	0.15	0.27	FKM	-	0	10	-10	75	8	220-230V/50Hz	131T23-2995-4818653D	
								0	10	-10	75	9	24 Vdc	131T23-2995-481865C2	
								2-22	0	10	-10	65	8	220-230V/50Hz	131T23-2995-4958703D
								0	10	-10	65	9	24 Vdc	131T23-2995-495870C2	
								1-21	0	10	-10	75	8	230V/50Hz	131T23-495905F4
								0	10	-10	75	8	24 Vdc	131T23-495905C2	
	4.5	7	9	0.42	0.54	FKM	-	0	2	-10	75	8	220-230V/50Hz	131T21-2995-4818653D	
								0	2	-10	75	9	24 Vdc	131T21-2995-481865C2	
								2-22	0	2	-10	65	8	220-230V/50Hz	131T21-2995-4958703D
								0	2	-10	65	9	24 Vdc	131T21-2995-495870C2	
								1-21	0	2	-10	75	8	230V/50Hz	131T21-495905F4
								0	2	-10	75	8	24 Vdc	131T21-495905C2	

Fast Delivery

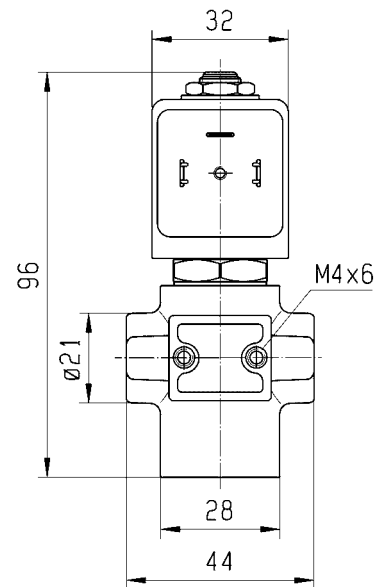
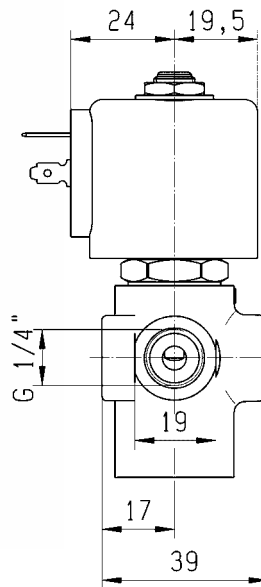

3/2

VALVES FOR ALL FLUIDS AND AIR DIRECT OPERATED

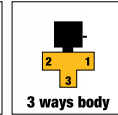
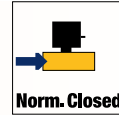

**BRASS
PIPE MOUNTING**

NORMALLY CLOSED

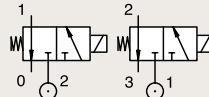

Port size	Orifice Ø	Flow factors				Seat Seal	Atex Zone	Operating Pressure Differential		Fluid Temp.		Power	Voltage	Solenoid Valve Order Number	
		1 Kv l/min	(2) Kv l/min	1 KV m³/h	(2) KV m³/h			Qn l/min	Min bar	Max bar	Min °C				Max °C
1/4"	2	2.5	4.5	0.15	0.27	140	FKM	-	0	10	-10	75	8	220-230V/50Hz	131T2301-2995-4818653D
								-	0	10	-10	75	9	24 Vdc	131T2301-2995-481865C2
								2-22	0	10	-10	65	8	220-230V/50Hz	131T2301-2995-4958703D
								2-22	0	10	-10	65	9	24 Vdc	131T2301-2995-495870C2
								1-21	0	10	-10	75	8	230V/50Hz	131T2301-495905F4
								1-21	0	10	-10	75	8	24 Vdc	131T2301-495905C2

Fast Delivery

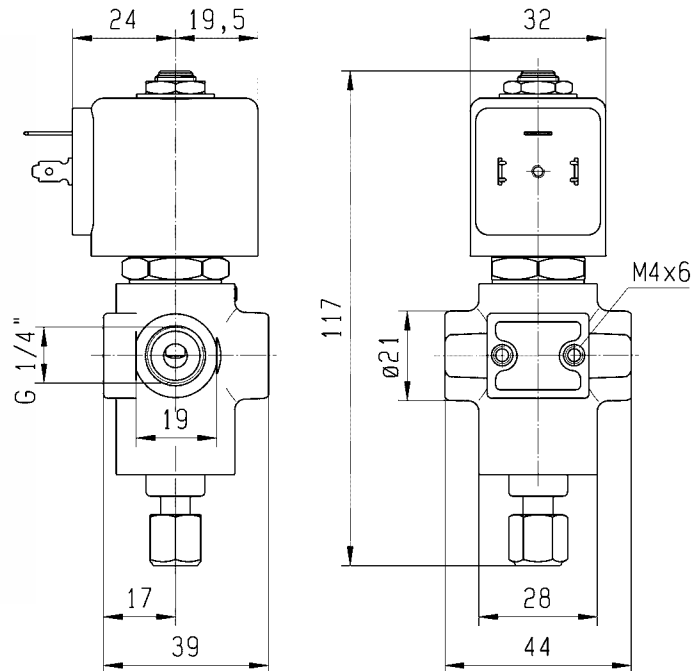

3 & 5 WAY VALVES

All Fluids & Air



3/2

VALVES FOR ALL FLUIDS AND AIR DIRECT OPERATED

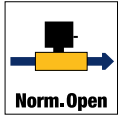

BRASS PIPE MOUNTING

NORMALLY OPEN

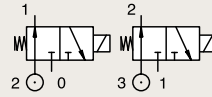

Port size	Orifice Ø	Flow factors				Seat Seal	Atex Zone	Operating Pressure Differential		Fluid Temp.		Power	Voltage	Solenoid Valve Order Number		
		1 Kv l/min	(2) Kv l/min	1 KV m³/h	(2) KV m³/h			Qn l/min	Min bar	Max bar	Min °C				Max °C	W
1/4"	2	1.8	1.8	0.11	0.11	125	FKM	-	0	10	-10	120	8	220-230V/50Hz	132K06-2995-4818653D	
									0	10	-10	120	9	24 Vdc	132K06-2995-481865C2	
									2-22	0	10	-10	65	8	220-230V/50Hz	132K06-2995-4958703D
									0	10	-10	65	9	24 Vdc	132K06-2995-495870C2	
									1-21	0	10	-10	80	8	230V/50Hz	132K06-495905F4
									0	10	-10	80	8	24 Vdc	132K06-495905C2	
	2.5	2.2	2.2	0.13	0.13	160	FKM	-	0	7	-10	120	8	220-230V/50Hz	132K03-2995-4818653D	
									0	7	-10	120	9	24 Vdc	132K03-2995-481865C2	
									2-22	0	7	-10	65	8	220-230V/50Hz	132K03-2995-4958703D
									0	7	-10	65	9	24 Vdc	132K03-2995-495870C2	
									1-21	0	7	-10	80	8	230V/50Hz	132K03-495905F4
									0	7	-10	80	8	24 Vdc	132K03-495905C2	

Fast Delivery

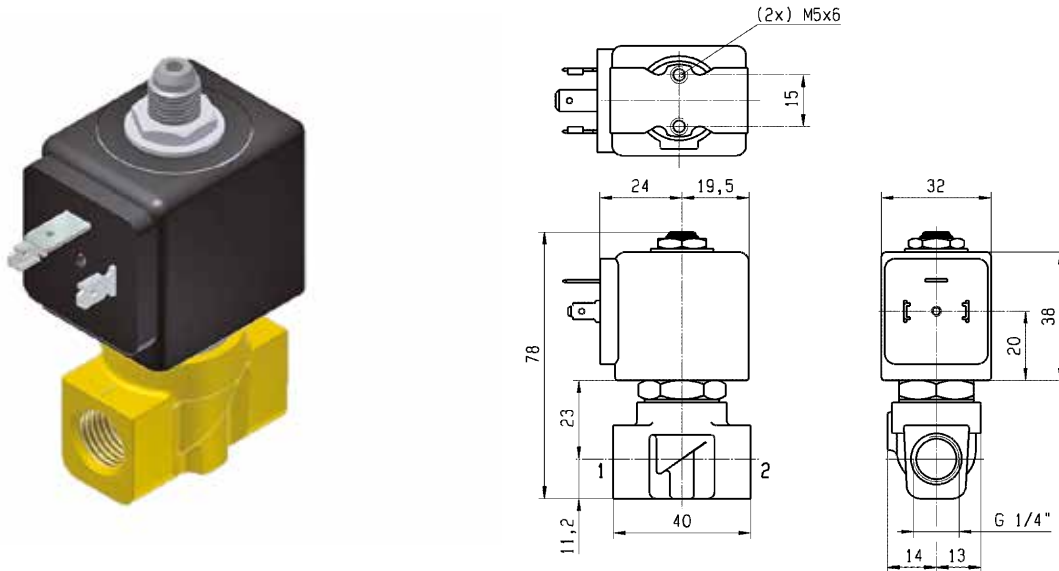

3/2

VALVES FOR ALL FLUIDS AND AIR DIRECT OPERATED

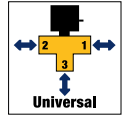

BRASS
PIPE MOUNTING

UNIVERSAL

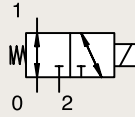

Port size	Orifice Ø	Flow factors				Seat Seal	Atex Zone	Operating Pressure Differential		Fluid Temp.		Power	Voltage	Solenoid Valve Order Number	
		1 Kv l/min	(2) Kv l/min	1 KV m³/h	(2) KV m³/h			Qn l/min	Min bar	Max bar	Min °C				Max °C
1/4"	0.8	0.3	0.3	0.02	0.02	23	FKM	-	0	30	-10	100	8	220-230V/50Hz	E133K05-2995-4818653D
								-	0	30	-10	100	9	24 Vdc	E133K05-2995-481865C2
								2-22	0	30	-10	65	8	220-230V/50Hz	E133K05-2995-4958703D
								2-22	0	30	-10	65	9	24 Vdc	E133K05-2995-495870C2
								1-21	0	30	-10	80	8	230V/50Hz	E133K05-495905F4
								1-21	0	30	-10	80	8	24 Vdc	E133K05-495905C2
	2	2.5	2.5	0.15	0.15	145	FKM	-	0	7	-10	100	8	220-230V/50Hz	E133K06-2995-4818653D
								-	0	7	-10	100	9	24 Vdc	E133K06-2995-481865C2
								2-22	0	7	-10	65	8	220-230V/50Hz	E133K06-2995-4958703D
								2-22	0	7	-10	65	9	24 Vdc	E133K06-2995-495870C2
								1-21	0	7	-10	80	8	230V/50Hz	E133K06-495905F4
								1-21	0	7	-10	80	8	24 Vdc	E133K06-495905C2

Fast Delivery

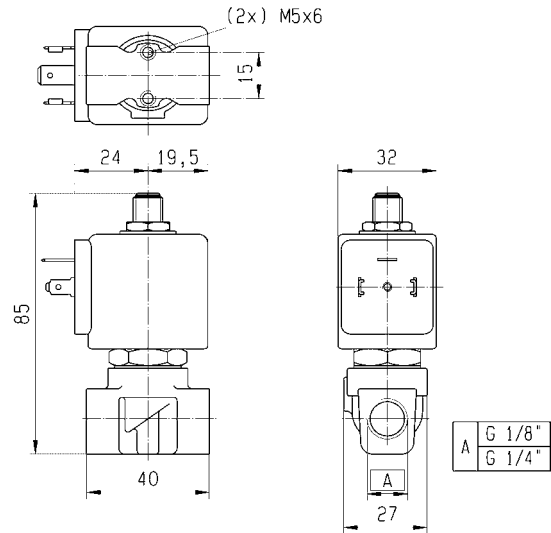

3 & 5 WAY VALVES

All Fluids & Air



3/2

VALVES FOR ALL FLUIDS AND AIR DIRECT OPERATED

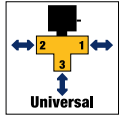

BRASS
PIPE MOUNTING

UNIVERSAL

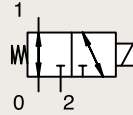

Port size	Orifice Ø	Flow factors			Seat Seal	Atex Zone	Operating Pressure Differential		Fluid Temp.		Power	Voltage	Solenoid Valve Order Number
		1 Kv l/min	(2) Kv l/min	1 KV m³/h			(2) Qn l/min	Min bar	Max bar	Min °C			
1/4"	2	2	0.12		FKM	-	0	7	-10	140	9	230V/50-60Hz	550079DIS
							0	7	-10	140	12	24 Vdc	550078DIS
	2.5	2.8	0.17				0	4	-10	140	9	230V/50-60Hz	550081DIS
							0	4	-10	140	12	24 Vdc	550080DIS
	3.5	5	0.30				0	1	-10	140	9	230V/50-60Hz	550083DIS
							0	1	-10	140	12	24 Vdc	550082DIS

Fast Delivery

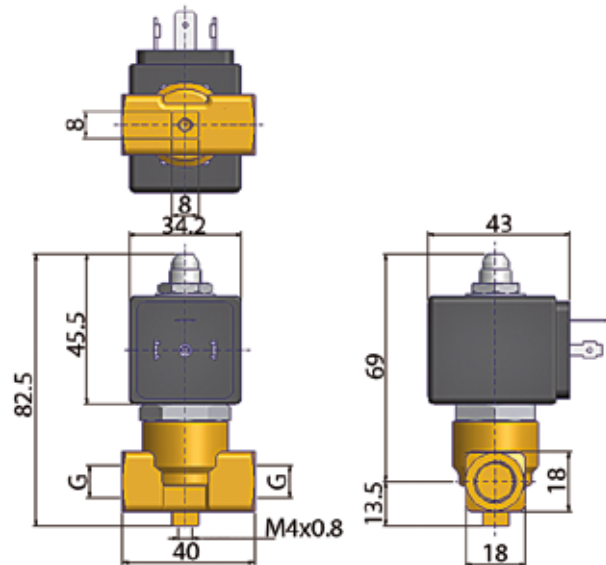

3/2

VALVES FOR ALL FLUIDS AND AIR
DIRECT OPERATED

3 & 5 WAY VALVES

All Fluids & Air



3/2

VALVES FOR ALL FLUIDS AND AIR DIRECT OPERATED

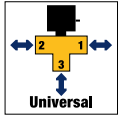

BRASS
PIPE MOUNTING

UNIVERSAL

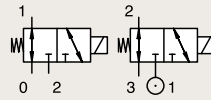

Port size	Orifice Ø	Flow factors				Seat Seal	Atex Zone	Operating Pressure Differential		Fluid Temp.		Power	Voltage	Solenoid Valve Order Number	
		1 Kv l/min	(2) Kv l/min	1 KV m³/h	(2) KV m³/h			Qn l/min	Min bar	Max bar	Min °C				Max °C
1/4"	2	2.5	2.5	0.15	0.15	140	FKM	-	0	7	-10	75	8	220-230V/50Hz	133T23-2995-4818653D
									0	7	-10	75	9	24 Vdc	133T23-2995-481865C2
									0	7	-10	65	8	220-230V/50Hz	133T23-2995-4958703D
									0	7	-10	65	9	24 Vdc	133T23-2995-495870C2
									0	7	-10	75	8	230V/50Hz	133T23-495905F4
									0	7	-10	75	8	24 Vdc	133T23-495905C2

Fast Delivery

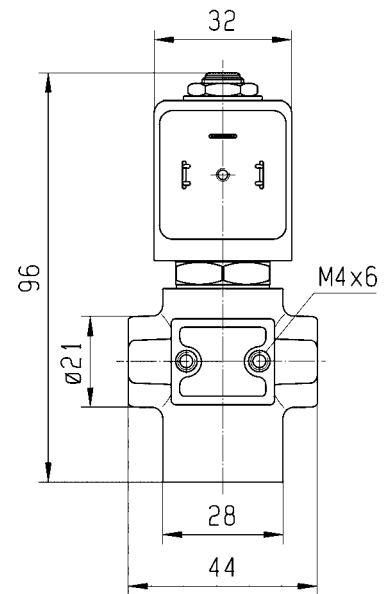
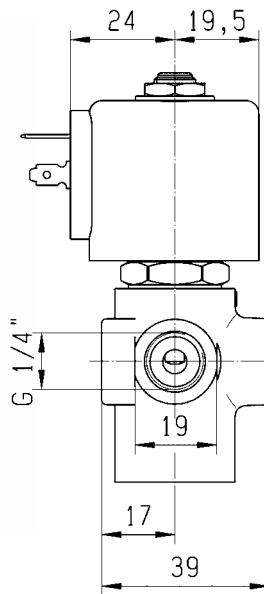

3/2

VALVES FOR ALL FLUIDS AND AIR DIRECT OPERATED

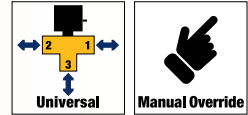

BRASS
PIPE MOUNTING

UNIVERSAL

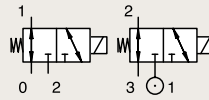

Port size	Orifice Ø	Flow factors				Seat Seal	Atex Zone	Operating Pressure Differential		Fluid Temp.		Power W	Voltage	Solenoid Valve Order Number	
		1 Kv l/min	(2) Kv l/min	1 KV m³/h	(2) KV m³/h			Qn l/min	Min bar	Max bar	Min °C				Max °C
1/4"	2	2.5	2.5	0.15	0.15	140	FKM	-	0	7	-10	75	8	220-230V/50Hz	133T2301-2995-4818653D
									0	7	-10	75	9	24 Vdc	133T2301-2995-481865C2
									0	7	-10	65	8	220-230V/50Hz	133T2301-2995-4958703D
									0	7	-10	65	9	24 Vdc	133T2301-2995-495870C2
									0	7	-10	75	8	230V/50Hz	133T2301-495905F4
									0	7	-10	75	8	24 Vdc	133T2301-495905C2

Fast Delivery

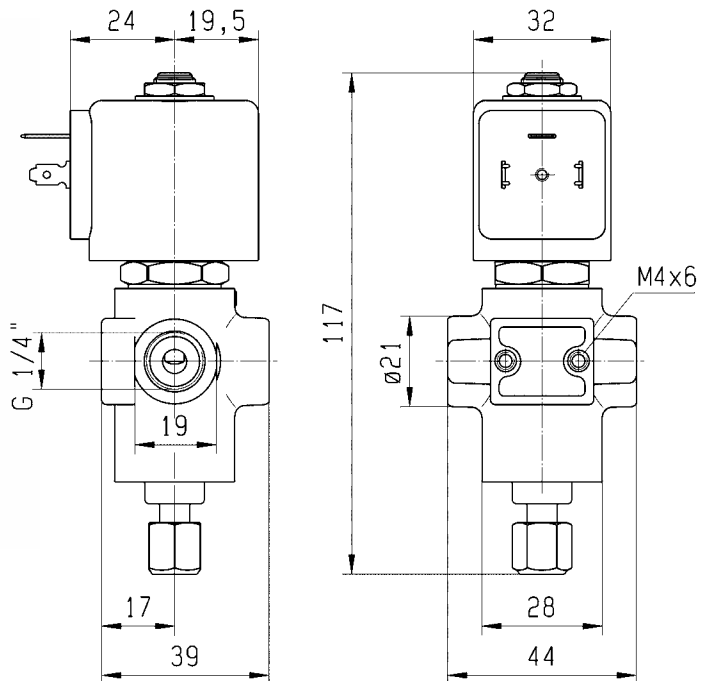

3 & 5 WAY VALVES

All Fluids & Air



3/2

VALVES FOR ALL FLUIDS AND AIR DIRECT OPERATED

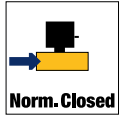

303 STAINLESS ST.
PIPE MOUNTING

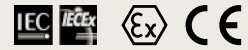
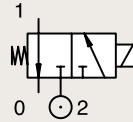

NORMALLY CLOSED

Port size	Orifice Ø	Flow factors				Seat Seal	Atex Zone	Operating Pressure Differential		Fluid Temp.		Power	Voltage	Solenoid Valve Order Number								
		1 Kv l/min	(2) Kv l/min	1 KV m³/h	(2) KV m³/h			Qn l/min	Min bar	Max bar	Min °C				Max °C							
1/4"	2.5	3.5	3.5	0.21	0.21	220	FKM	-	0	7	-10	120	8	220-230V/50Hz	131V5306-2995-4818653D							
									0	7	-10	120	9	24 Vdc	131V5306-2995-481865C2							
									0	7	-10	65	8	220-230V/50Hz	131V5306-2995-4958703D							
									0	7	-10	65	9	24 Vdc	131V5306-2995-495870C2							
									0	7	-10	80	8	230V/50Hz	131V5306-495905F4							
									0	7	-10	80	8	24 Vdc	131V5306-495905C2							
									ATEX													

Fast Delivery

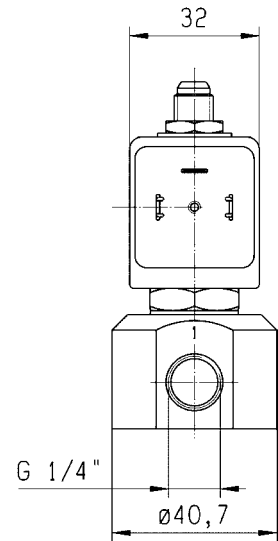
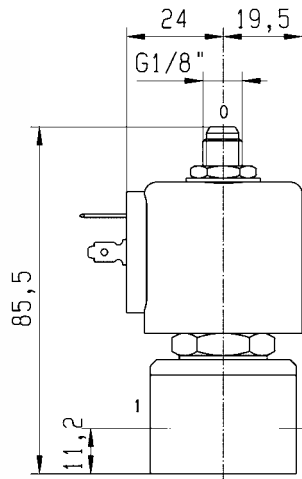

3/2

VALVES FOR ALL FLUIDS AND AIR DIRECT OPERATED

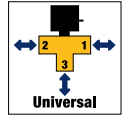

303 STAINLESS ST.
PIPE MOUNTING

UNIVERSAL

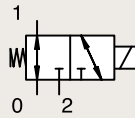

Port size	Orifice Ø	Flow factors				Seat Seal	Atex Zone	Operating Pressure Differential		Fluid Temp.		Power	Voltage	Solenoid Valve Order Number	
		1 Kv l/min	(2) Kv l/min	1 KV m³/h	(2) KV m³/h			Qn l/min	Min bar	Max bar	Min °C				Max °C
1/4"	1.5	1.5	1.5	0.09	0.09	80	FKM	-	0	10	-10	100	8	220-230V/50Hz	133V5406-2995-4818653D
									0	10	-10	100	9	24 Vdc	133V5406-2995-481865C2
									0	10	-10	65	8	220-230V/50Hz	133V5406-2995-4958703D
									0	10	-10	65	9	24 Vdc	133V5406-2995-495870C2
									0	10	-10	80	8	230V/50Hz	133V5406-495905F4
									0	10	-10	80	8	24 Vdc	133V5406-495905C2

Fast Delivery

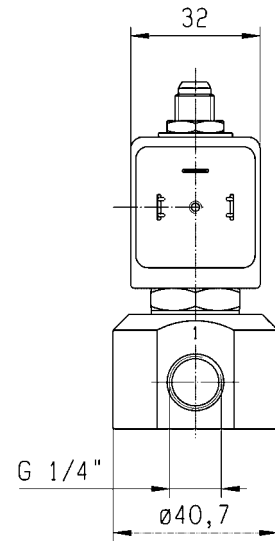
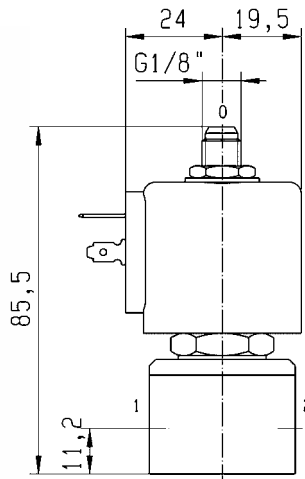

3 & 5 WAY VALVES

All Fluids & Air



3/2

VALVES FOR ALL FLUIDS AND AIR DIRECT OPERATED

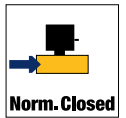

316L STAINLESS ST.
PIPE MOUNTING

NORMALLY CLOSED

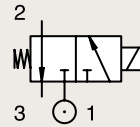

Port size	Orifice Ø	Flow factors			Seat Seal	Atex Zone	Operating Pressure Differential		Fluid Temp.		Power	Voltage	Solenoid Valve Order Number
		1 Kv l/min	(2) Kv l/min	1 KV m³/h			(2) Qn l/min	Min bar	Max bar	Min °C			
1/8"	1.5	1	0.06	-	FKM	-	0	8	-10	140	4	220-230V/50Hz	550015DIS
							0	8	-10	140	5	24 Vdc	550014DIS
1/4"	1.5	1	0.06	-	FKM	-	0	8	-10	140	4	220-230V/50Hz	550017DIS
							0	8	-10	140	5	24 Vdc	550016DIS

Fast Delivery

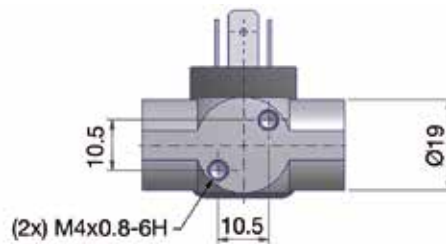
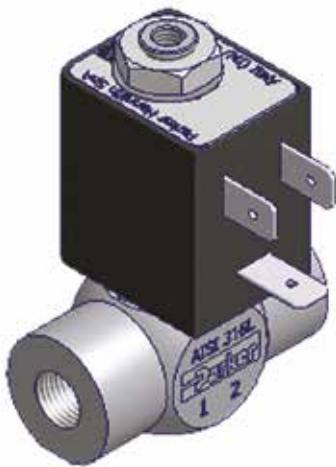

Port Size
A
1/8"
1/4"

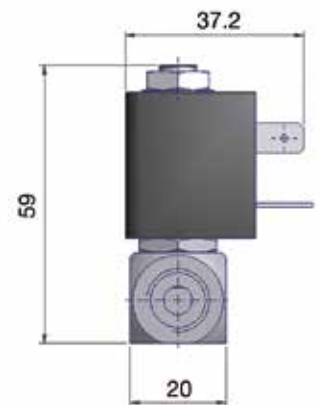
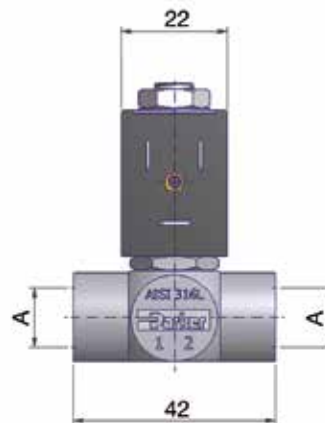

SPARE PARTS

TABLE OF CONTENT

LIST OF REPAIR KITS, SPARE COILS, DIN PLUGS88

COILS FOR DIN PLUG CONNECTION

481865 - Coils 32 mm	94
492425 - High temperature coils 32 mm.....	95
488980 - Coils 22 mm.....	96
496131 - Double frequency coils 22 mm.....	97
WB4.5 / WB5.0 - Coils series 22 mm.....	98
ZB09 / ZB12 - Coils series	99
ZB14 / ZB16 / ZH14 / ZH16 - High power high temperature coils series.....	100
JB14 / JB16 - Coils series.....	101
D4 - UL coils series 32 mm	102
D5 - Coils series 32 mm	103
DG - Coils series 22 mm.....	104

ELECTRICAL PARTS "nAc nCc" ATEX Zone 2/22

495865 - Electrical part low power 22 mm.....	105
496637 - Electrical part double frequency 22 mm.....	106
495870 - Electrical part 32 mm.....	107

ENCAPSULATED ELECTRICAL PARTS "mb" ATEX Zone 1/21

482605 / 482606 - Electrical part low power 22 mm.....	108
--	-----

FLAME PROOF ENCAPSULATED ELECTRICAL PARTS "db mb" ATEX Zone 1/21

495905 - Electrical parts 37 mm.....	109
--------------------------------------	-----

LIST OF REPAIR KITS, SPARE COILS, DIN PLUGS

Solenoid Valve	Repair Kit	Spare Coil	DIN Plug
121K01-2995-4818653D	-	4818653D	600003PLUG
121K01-2995-481865C2	-	481865C2	600003PLUG
121K01-2995-492425C2	-	492425C2	600003PLUG
121K01-2995-4958703D	-	4958703D	-
121K01-2995-495870C2	-	495870C2	-
121K01-495905C2	-	495905C2	-
121K01-495905F4	-	495905F4	-
121K02-2995-4818653D	-	4818653D	600003PLUG
121K02-2995-481865C2	-	481865C2	600003PLUG
121K02-2995-492425C2	-	492425C2	600003PLUG
121K02-2995-492425F4	-	492425F4	600003PLUG
121K02-2995-4958703D	-	4958703D	-
121K02-2995-495870C2	-	495870C2	-
121K02-495905C2	-	495905C2	-
121K02-495905F4	-	495905F4	-
121K0250-2995-4818653D	-	4818653D	600003PLUG
121K0250-2995-481865C2	-	481865C2	600003PLUG
121K0250-2995-4958703D	-	4958703D	-
121K0250-2995-495870C2	-	495870C2	-
121K0250-495905C2	-	495905C2	-
121K0250-495905F4	-	495905F4	-
121K0706-2995-4818653D	-	4818653D	600003PLUG
121K0706-2995-481865C2	-	481865C2	600003PLUG
121K0706-2995-492425C2	-	492425C2	600003PLUG
121K0706-2995-4958703D	-	4958703D	-
121K0706-2995-495870C2	-	495870C2	-
121K0706-495905C2	-	495905C2	-
121K0706-495905F4	-	495905F4	-
121K3106-2995-4818653D	-	4818653D	600003PLUG
121K3106-2995-481865C2	-	481865C2	600003PLUG
121K3106-2995-492425C2	-	492425C2	600003PLUG
121K3106-2995-4958703D	-	4958703D	-
121K3106-2995-495870C2	-	495870C2	-
121K3106-495905C2	-	495905C2	-
121K3106-495905F4	-	495905F4	-
121K3306-2995-4818653D	-	4818653D	600003PLUG
121K3306-2995-481865C2	-	481865C2	600003PLUG
121K3306-2995-492425C2	-	492425C2	600003PLUG
121K3306-2995-492425F4	-	492425F4	600003PLUG
121K3306-2995-4958703D	-	4958703D	-
121K3306-2995-495870C2	-	495870C2	-
121K3306-495905C2	-	495905C2	-
121K3306-495905F4	-	495905F4	-
121V5163-2995-4818653D	-	4818653D	600003PLUG
121V5163-2995-481865C2	-	481865C2	600003PLUG
121V5363-2995-4818653D	-	4818653D	600003PLUG
121V5363-2995-481865C2	-	481865C2	600003PLUG
121V5463-2995-4818653D	-	4818653D	600003PLUG
121V5463-2995-481865C2	-	481865C2	600003PLUG
122K83-2995-4818653D	-	4818653D	600003PLUG
122K83-2995-481865C2	-	481865C2	600003PLUG
122K83-2995-4958703D	-	4958703D	-
122K83-2995-495870C2	-	495870C2	-
122K83-495905C2	-	495905C2	-
122K83-495905F4	-	495905F4	-
122K8306-2995-4818653D	-	4818653D	600003PLUG
122K8306-2995-481865C2	-	481865C2	600003PLUG

Solenoid Valve	Repair Kit	Spare Coil	DIN Plug
122K8306-2995-4958703D	-	4958703D	-
122K8306-2995-495870C2	-	495870C2	-
122K8306-495905C2	-	495905C2	-
122K8306-495905F4	-	495905F4	-
122K84-2995-4818653D	-	4818653D	600003PLUG
122K84-2995-481865C2	-	481865C2	600003PLUG
122K84-2995-4958703D	-	4958703D	-
122K84-2995-495870C2	-	495870C2	-
122K84-495905C2	-	495905C2	-
122K84-495905F4	-	495905F4	-
131B04-482605C2	-	482605C2	-
131B04-496131C2	-	496131C2	600040
131B04-496131P9	-	496131P9	600040
131B04-496637C2	-	496637C2	-
131B04-496637P9	-	496637P9	-
131B14-482605C2	-	482605C2	-
131B14-496131C2	-	496131C2	600040
131B14-496131P9	-	496131P9	600040
131B14-496637C2	-	496637C2	-
131B14-496637P9	-	496637P9	-
131K1650-2995-4818653D	-	4818653D	600003PLUG
131K1650-2995-481865C2	-	481865C2	600003PLUG
131K1650-2995-495870C2	-	495870C2	-
131K1650-2995-495870F4	-	495870F4	-
131K1650-495905C2	-	495905C2	-
131K1650-495905F4	-	495905F4	-
131M14-482606C2	-	482606C2	-
131M14-826063D	-	4826063D	-
131M14-8993-4889803D	-	4889803D	600040
131M14-8993-488980C2	-	488980C2	600040
131M14-8993-4958653D	-	4958653D	-
131M14-8993-495865C2	-	495865C2	-
131M15-4826063D	-	4826063D	-
131M15-482606C2	-	482606C2	-
131M15-8993-4889803D	-	4889803D	600040
131M15-8993-488980C2	-	488980C2	600040
131M15-8993-4958653D	-	4958653D	-
131M15-8993-495865C2	-	495865C2	-
131T21-2995-4818653D	-	4818653D	600003PLUG
131T21-2995-481865C2	-	481865C2	600003PLUG
131T21-2995-4958703D	-	4958703D	-
131T21-2995-495870C2	-	495870C2	-
131T21-495905C2	-	495905C2	-
131T21-495905F4	-	495905F4	-
131T23-2995-4818653D	-	4818653D	600003PLUG
131T23-2995-481865C2	-	481865C2	600003PLUG
131T23-2995-4958703D	-	4958703D	-
131T23-2995-495870C2	-	495870C2	-
131T23-495905C2	-	495905C2	-
131T23-495905F4	-	495905F4	-
131T2301-2995-4818653D	-	4818653D	600003PLUG
131T2301-2995-481865C2	-	481865C2	600003PLUG
131T2301-2995-495870C2	-	495870C2	-
131T2301-2995-495870F4	-	495870F4	-
131T2301-495905C2	-	495905C2	-
131T2301-495905F4	-	495905F4	-
131V5306-2995-4818653D	-	4818653D	600003PLUG



LIST OF REPAIR KITS, SPARE COILS, DIN PLUGS

Solenoid Valve	Repair Kit	Spare Coil	DIN Plug
131V5306-2995-481865C2	-	481865C2	600003PLUG
131V5306-2995-4958703D	-	4958703D	-
131V5306-2995-495870C2	-	495870C2	-
131V5306-495905C2	-	495905C2	-
131V5306-495905F4	-	495905F4	-
132K03-2995-4818653D	-	4818653D	600003PLUG
132K03-2995-481865C2	-	481865C2	600003PLUG
132K03-2995-4958703D	-	4958703D	-
132K03-2995-495870C2	-	495870C2	-
132K03-495905C2	-	495905C2	-
132K03-495905F4	-	495905F4	-
132K06-2995-4818653D	-	4818653D	600003PLUG
132K06-2995-481865C2	-	481865C2	600003PLUG
132K06-2995-4958703D	-	4958703D	-
132K06-2995-495870C2	-	495870C2	-
132K06-495905C2	-	495905C2	-
132K06-495905F4	-	495905F4	-
133T23-2995-4818653D	-	4818653D	600003PLUG
133T23-2995-481865C2	-	481865C2	600003PLUG
133T23-2995-4958703D	-	4958703D	-
133T23-2995-495870C2	-	495870C2	-
133T23-495905C2	-	495905C2	-
133T23-495905F4	-	495905F4	-
133T2301-2995-4818653D	-	4818653D	600003PLUG
133T2301-2995-481865C2	-	481865C2	600003PLUG
133T2301-2995-495870C2	-	495870C2	-
133T2301-2995-495870F4	-	495870F4	-
133T2301-495905C2	-	495905C2	-
133T2301-495905F4	-	495905F4	-
133V5406-2995-4818653D	-	4818653D	600003PLUG
133V5406-2995-481865C2	-	481865C2	600003PLUG
133V5406-2995-4958703D	-	4958703D	-
133V5406-2995-495870C2	-	495870C2	-
133V5406-495905C2	-	495905C2	-
133V5406-495905F4	-	495905F4	-
221G13-2995-4818653D	481203105	4818653D	600003PLUG
221G13-2995-492425C2	481203105	492425C2	600003PLUG
221G13-2995-4958703D	481203105	4958703D	-
221G13-495905F4	481203105	495905F4	-
221G1303-2995-4818653D	481203106	4818653D	600003PLUG
221G15-2995-4818653D	481203105	4818653D	600003PLUG
221G15-2995-492425C2	481203105	492425C2	600003PLUG
221G15-2995-4958703D	481203105	4958703D	-
221G15-495905F4	481203105	495905F4	-
221G1503-2995-4818653D	481203106	4818653D	600003PLUG
221G1530-2995-481865C2	481203319	481865C2	600003PLUG
221G1530-2995-495870C2	481203319	495870C2	-
221G1530-495905C2	481203319	495905C2	-
221G16-2995-4818653D	481203105	4818653D	600003PLUG
221G16-2995-492425C2	481203105	492425C2	600003PLUG
221G16-2995-4958703D	481203105	4958703D	-
221G16-495905F4	481203105	495905F4	-
221G1603-2995-4818653D	481203106	4818653D	600003PLUG
221G17-2995-4818653D	481203105	4818653D	600003PLUG
221G17-2995-492425C2	481203105	492425C2	600003PLUG
221G17-2995-4958703D	481203105	4958703D	-
221G17-495905F4	481203105	495905F4	-

Solenoid Valve	Repair Kit	Spare Coil	DIN Plug
221G1703-2995-4818653D	481203106	4818653D	600003PLUG
221G21-2995-4818653D	481203086	4818653D	600003PLUG
221G21-2995-492425C2	481203086	492425C2	600003PLUG
221G21-2995-4958703D	481203086	4958703D	-
221G21-495905F4	481203086	495905F4	-
221G2130-2995-481865C2	481203321	481865C2	600003PLUG
221G2130-2995-495870C2	481203321	495870C2	-
221G2130-495905C2	481203321	495905C2	-
221G25-2995-4818653D	481203108	4818653D	600003PLUG
221G25-2995-492425C2	481203108	492425C2	600003PLUG
221G25-2995-4958703D	481203108	4958703D	-
221G25-495905F4	481203108	495905F4	-
221G2530-2995-481865C2	481203324	481865C2	600003PLUG
221G2530-2995-495870C2	481203324	495870C2	-
221G2530-495905C2	481203324	495905C2	-
221G26-2995-4818653D	481203108	4818653D	600003PLUG
221G26-2995-492425C2	481203108	492425C2	600003PLUG
221G26-2995-4958703D	481203108	4958703D	-
221G26-495905F4	481203108	495905F4	-
221S10F-2995-4818653D	221S10F-KIT	4818653D	600003PLUG
221S15F-2995-4818653D	221S15F-KIT	4818653D	600003PLUG
221S20F-2995-4818653D	221S20F-KIT	4818653D	600003PLUG
221S25F-2995-4818653D	221S15F-KIT	4818653D	600003PLUG
321K3106-4826063D	481203246	4826063D	-
321K3106-482606C2	481203246	482606C2	-
321K3106-8993-4889803D	481203246	4889803D	600040
321K3106-8993-488980C2	481203246	488980C2	600040
321K3106-8993-4958653D	481203246	4958653D	-
321K3106-8993-495865C2	481203246	495865C2	-
321K3306-4826063D	481203246	4826063D	-
321K3306-482606C2	481203246	482606C2	-
321K3306-8993-4889803D	481203246	4889803D	600040
321K3306-8993-488980C2	481203246	488980C2	600040
321K3306-8993-4958653D	481203246	4958653D	-
321K3306-8993-495865C2	481203246	495865C2	-
321K35-4826063D	481203241	4826063D	-
321K35-482606C2	481203241	482606C2	-
321K35-8993-4889803D	481203241	4889803D	600040
321K35-8993-488980C2	481203241	488980C2	600040
321K35-8993-4958653D	481203241	4958653D	-
321K35-8993-495865C2	481203241	495865C2	-
321K3506-4826063D	481203246	4826063D	-
321K3506-482606C2	481203246	482606C2	-
321K3506-8993-4889803D	481203246	4889803D	600040
321K3506-8993-488980C2	481203246	488980C2	600040
321K3506-8993-4958653D	481203246	4958653D	-
321K3506-8993-495865C2	481203246	495865C2	-
321K36-4826063D	481203242	4826063D	-
321K36-482606C2	481203242	482606C2	-
321K36-8993-4889803D	481203242	4889803D	600040
321K36-8993-488980C2	481203242	488980C2	600040
321K36-8993-4958653D	481203242	4958653D	-
321K36-8993-495865C2	481203242	495865C2	-
321K3606-4826063D	481203247	4826063D	-
321K3606-482606C2	481203247	482606C2	-
321K3606-8993-4889803D	481203247	4889803D	600040
321K3606-8993-488980C2	481203247	488980C2	600040

SPARE PARTS
Repair Kits, Coils & Plugs



LIST OF REPAIR KITS, SPARE COILS, DIN PLUGS

Solenoid Valve	Repair Kit	Spare Coil	DIN Plug
321K3606-8993-4958653D	481203247	4958653D	-
321K3606-8993-495865C2	481203247	495865C2	-
321K37-4826063D	481203242	4826063D	-
321K37-482606C2	481203242	482606C2	-
321K37-8993-4889803D	481203242	4889803D	600040
321K37-8993-488980C2	481203242	488980C2	600040
321K37-8993-4958653D	481203242	4958653D	-
321K37-8993-495865C2	481203242	495865C2	-
321K3706-4826063D	481203247	4826063D	-
321K3706-482606C2	481203247	482606C2	-
321K3706-8993-4889803D	481203247	4889803D	600040
321K3706-8993-488980C2	481203247	488980C2	600040
321K3706-8993-4958653D	481203247	4958653D	-
321K3706-8993-495865C2	481203247	495865C2	-
322G75-2995-4818653D	481203066	4818653D	600003PLUG
322G75-2995-481865C2	481203066	481865C2	600003PLUG
322G75-2995-4958703D	481203066	4958703D	-
322G75-2995-495870C2	481203066	495870C2	-
322G75-495905C2	481203066	495905C2	-
322G75-495905F4	481203066	495905F4	-
322H75-2995-4818653D	48120308	4818653D	600003PLUG
322H75-2995-481865C2	48120308	481865C2	600003PLUG
322H75-2995-4958703D	48120308	4958703D	-
322H75-2995-495870C2	48120308	495870C2	-
322H75-495905C2	48120308	495905C2	-
322H75-495905F4	48120308	495905F4	-
322H7506-2995-4818653D	481203081	4818653D	600003PLUG
322H7506-2995-481865C2	481203081	481865C2	600003PLUG
322H7506-2995-4958703D	481203081	4958703D	-
322H7506-2995-495870C2	481203081	495870C2	-
322H7506-495905C2	481203081	495905C2	-
322H7506-495905F4	481203081	495905F4	-
322K4106-2995-4818653D	481203245	4818653D	600003PLUG
322K4106-2995-481865C2	481203245	481865C2	600003PLUG
322K4106-2995-4958703D	481203245	4958703D	-
322K4106-2995-495870C2	481203245	495870C2	-
322K4106-495905C2	481203245	495905C2	-
322K4106-495905F4	481203245	495905F4	-
322K4506-2995-4818653D	481203245	4818653D	600003PLUG
322K4506-2995-481865C2	481203245	481865C2	600003PLUG
322K4506-2995-4958703D	481203245	4958703D	-
322K4506-2995-495870C2	481203245	495870C2	-
322K4506-495905C2	481203245	495905C2	-
322K4506-495905F4	481203245	495905F4	-
322K4606-2995-4818653D	48120325	4818653D	600003PLUG
322K4606-2995-481865C2	48120325	481865C2	600003PLUG
322K4606-2995-4958703D	48120325	4958703D	-
322K4606-2995-495870C2	48120325	495870C2	-
322K4606-495905C2	48120325	495905C2	-
322K4606-495905F4	48120325	495905F4	-
331N04-496131C2	-	496131C2	600040
331N04-496131P9	-	496131P9	600040
331N04-496637C2	-	496637C2	-
331N04-496637P9	-	496637P9	-
331N34-2995-4818653D	-	4818653D	600003PLUG
331N34-2995-481865C2	-	481865C2	600003PLUG
331N34-2995-4958703D	-	4958703D	-

Solenoid Valve	Repair Kit	Spare Coil	DIN Plug
331N34-2995-495870C2	-	495870C2	-
331N34-495905C2	-	495905C2	-
331N34-495905F4	-	495905F4	-
341N04-496131C2	-	496131C2	600040
341N04-496131P9	-	496131P9	600040
341N04-496637C2	-	496637C2	-
341N04-496637P9	-	496637P9	-
341N05-496131C2	-	496131C2	600040
341N05-496131P9	-	496131P9	600040
341N05-496637C2	-	496637C2	-
341N05-496637P9	-	496637P9	-
341N34-2995-4818653D	-	4818653D	600003PLUG
341N34-2995-481865C2	-	481865C2	600003PLUG
341N34-2995-4958703D	-	4958703D	-
341N34-2995-495870C2	-	495870C2	-
341N34-495905C2	-	495905C2	-
341N34-495905F4	-	495905F4	-
341N35-2995-4818653D	-	4818653D	600003PLUG
341N35-2995-481865C2	-	481865C2	600003PLUG
341N35-2995-4958703D	-	4958703D	-
341N35-2995-495870C2	-	495870C2	-
341N35-495905C2	-	495905C2	-
341N35-495905F4	-	495905F4	-
341P03-496131C2	-	496131C2	600040
341P03-496131P9	-	496131P9	600040
341P03-496637C2	-	496637C2	-
341P03-496637P9	-	496637P9	-
341P04-496131C2	-	496131C2	600040
341P04-496131P9	-	496131P9	600040
341P04-496637C2	-	496637C2	-
341P04-496637P9	-	496637P9	-
347N03-496131C2	-	496131C2	600040
347N03-496131P9	-	496131P9	600040
347N03-496637C2	-	496637C2	-
347N03-496637P9	-	496637P9	-
347N04-496131C2	-	496131C2	600040
347N04-496131P9	-	496131P9	600040
347N04-496637C2	-	496637C2	-
347N04-496637P9	-	496637P9	-
347N33-2995-4818653D	-	4818653D	600003PLUG
347N33-2995-481865C2	-	481865C2	600003PLUG
347N33-2995-4958703D	-	4958703D	-
347N33-2995-495870C2	-	495870C2	-
347N33-495905C2	-	495905C2	-
347N33-495905F4	-	495905F4	-
347N34-2995-4818653D	-	4818653D	600003PLUG
347N34-2995-481865C2	-	481865C2	600003PLUG
347N34-2995-4958703D	-	4958703D	-
347N34-2995-495870C2	-	495870C2	-
347N34-495905C2	-	495905C2	-
347N34-495905F4	-	495905F4	-
347P03-496131C2	-	496131C2	600040
347P03-496131P9	-	496131P9	600040
347P03-496637C2	-	496637C2	-
347P03-496637P9	-	496637P9	-
347P04-496131C2	-	496131C2	600040
347P04-496131P9	-	496131P9	600040



LIST OF REPAIR KITS, SPARE COILS, DIN PLUGS

Solenoid Valve	Repair Kit	Spare Coil	DIN Plug
347P04-496637C2	-	496637C2	-
347P04-496637P9	-	496637P9	-
55000DIS	-	DGB	600040
55001DIS	-	DGL	600040
55002DIS	-	DGB	600040
55003DIS	-	DGL	600040
55004DIS	-	DGB	600040
55005DIS	-	DGL	600040
55006DIS	-	D4B	60003PLUG
55007DIS	-	D4G	60003PLUG
55008DIS	-	D4B	60003PLUG
55009DIS	-	D4G	60003PLUG
55010DIS	-	D4B	60003PLUG
55011DIS	-	D4G	60003PLUG
55012DIS	-	D5B	60003PLUG
55013DIS	-	D5L	60003PLUG
55014DIS	-	DGB	600040
55015DIS	-	DGL	600040
55016DIS	-	DGB	600040
55017DIS	-	DGL	600040
55018DIS	430133W	481865C2	60003PLUG
55019DIS	430133W	4818653D	60003PLUG
55020DIS	430088W	481865C2	60003PLUG
55021DIS	430088W	4818653D	60003PLUG
55022DIS	430088W	481865C2	60003PLUG
55023DIS	430088W	4818653D	60003PLUG
55024DIS	430090W	481865C2	60003PLUG
55025DIS	430090W	4818653D	60003PLUG
55026DIS	-	481865C2	60003PLUG
55027DIS	-	4818653D	60003PLUG
55028DIS	-	481865C2	60003PLUG
55029DIS	-	4818653D	60003PLUG
55030DIS	430089W	481865C2	60003PLUG
55031DIS	430089W	4818653D	60003PLUG
55032DIS	430095W	481865C2	60003PLUG
55033DIS	430095W	4818653D	60003PLUG
55034DIS	430095W	481865C2	60003PLUG
55035DIS	430095W	4818653D	60003PLUG
55036DIS	430133W	481865C2	60003PLUG
55037DIS	430133W	4818653D	60003PLUG
55038DIS	430088W	481865C2	60003PLUG
55039DIS	430088W	4818653D	60003PLUG
55040DIS	430090W	481865C2	60003PLUG
55041DIS	430090W	4818653D	60003PLUG
55042DIS	-	481865C2	60003PLUG
55043DIS	-	4818653D	60003PLUG
55044DIS	-	481865C2	60003PLUG
55045DIS	-	4818653D	60003PLUG
55046DIS	430137W	481865C2	60003PLUG
55047DIS	430137W	4818653D	60003PLUG
55048DIS	430138W	481865C2	60003PLUG
55049DIS	430138W	4818653D	60003PLUG
55050DIS	430138W	481865C2	60003PLUG
55051DIS	430138W	4818653D	60003PLUG
55052DIS	430139W	481865C2	60003PLUG
55053DIS	430139W	4818653D	60003PLUG
55054DIS	430140W	481865C2	60003PLUG

Solenoid Valve	Repair Kit	Spare Coil	DIN Plug
550055DIS	430140W	4818653D	60003PLUG
550056DIS	430137W	481865C2	60003PLUG
550057DIS	430137W	4818653D	60003PLUG
550058DIS	-	WB5.0 24 VDC	600040
550059DIS	-	WB4.5 230V/50-60HZ	600040
550060DIS	-	WB5.0 24 VDC	600040
550061DIS	-	WB4.5 230V/50-60HZ	600040
550062DIS	-	WB4.5 230V/50-60HZ	600040
550063DIS	-	WB4.5 230V/50-60HZ	600040
550064DIS	430141	ZB09 230V/50-60HZ	60003PLUG
550065DIS	430142	JB14 230V/50-60HZ	60003PLUG
550066DIS	430141	ZB09 230V/50-60HZ	60003PLUG
550067DIS	-	ZB09 230V/50-60HZ	60003PLUG
550071DIS	430142	JB14 230V/50-60HZ	60003PLUG
550072DIS	-	ZH14 230V/50-60HZ	60003PLUG
550073DIS	-	ZH16 24 VDC	60003PLUG
550074DIS	-	ZH14 230V/50-60HZ	60003PLUG
550075DIS	-	ZH16 24 VDC	60003PLUG
550076DIS	-	ZH14 230V/50-60HZ	60003PLUG
550077DIS	-	ZH14 230V/50-60HZ	60003PLUG
550078DIS	-	ZB12 24 VDC	60003PLUG
550079DIS	-	ZB09 230V/50-60HZ	60003PLUG
550080DIS	-	ZB12 24 VDC	60003PLUG
550081DIS	-	ZB09 230V/50-60HZ	60003PLUG
550082DIS	-	ZB12 24 VDC	60003PLUG
550083DIS	-	ZB09 230V/50-60HZ	60003PLUG
550084DIS	-	ZB12 24 VDC	60003PLUG
550085DIS	-	ZB09 230V/50-60HZ	60003PLUG
550086DIS	-	ZB12 24 VDC	60003PLUG
550087DIS	-	ZB09 230V/50-60HZ	60003PLUG
550088DIS	-	ZB12 24 VDC	60003PLUG
550089DIS	-	ZB09 230V/50-60HZ	60003PLUG
550090DIS	-	ZB09 230V/50-60HZ	60003PLUG
550091DIS	-	ZB14 230V/50-60HZ	60003PLUG
550092DIS	-	ZB16 24 VDC	60003PLUG
550093DIS	-	ZB12 24 VDC	60003PLUG
550094DIS	-	ZB09 230V/50-60HZ	60003PLUG
550095DIS	-	ZB12 24 VDC	60003PLUG
550096DIS	-	ZB09 230V/50-60HZ	60003PLUG
550097DIS	-	ZB12 24 VDC	60003PLUG
550098DIS	-	ZB09 230V/50-60HZ	60003PLUG
550099DIS	-	ZB12 24 VDC	60003PLUG
550100DIS	-	ZB09 230V/50-60HZ	60003PLUG
550101DIS	306206SP	ZB09 230V/50-60HZ	60003PLUG
550102DIS	306210SP	ZB09 230V/50-60HZ	60003PLUG
550103DIS	306210SP	ZB09 230V/50-60HZ	60003PLUG
550104DIS	306206SP	ZB09 230V/50-60HZ	60003PLUG
550105DIS	306221SP	ZB12 24 VDC	60003PLUG
550106DIS	306221SP	ZB09 230V/50-60HZ	60003PLUG
550107DIS	306223SP	ZB12 24 VDC	60003PLUG
550108DIS	306223SP	ZB09 230V/50-60HZ	60003PLUG
550109DIS	306223SP	ZB12 24 VDC	60003PLUG
550110DIS	306223SP	ZB09 230V/50-60HZ	60003PLUG
550111DIS	306221SP	ZB12 24 VDC	60003PLUG
550112DIS	306221SP	ZB09 230V/50-60HZ	60003PLUG
550119DIS	430090W	495905C2	-
550120DIS	430090W	495905F4	-

SPARE PARTS
Repair Kits, Coils & Plugs



LIST OF REPAIR KITS, SPARE COILS, DIN PLUGS

Solenoid Valve	Repair Kit	Spare Coil	DIN Plug
550135DIS	430090W	495905C2	-
550136DIS	430090W	495905F4	-
550141DIS	430137W	495905C2	-
550142DIS	430137W	495905F4	-
550143DIS	430138W	495905C2	-
550144DIS	430138W	495905F4	-
550145DIS	430138W	495905C2	-
550146DIS	430138W	495905F4	-
550147DIS	430139W	495905C2	-
550148DIS	430139W	495905F4	-
550149DIS	430140W	495905C2	-
550150DIS	430140W	495905F4	-
550151DIS	430137W	495905C2	-
550152DIS	430137W	495905F4	-
550159DIS	430090W	495870C2	-
550160DIS	430090W	4958703D	-
550175DIS	430090W	495870C2	-
550176DIS	430090W	4958703D	-
550181DIS	430137W	495870C2	-
550182DIS	430137W	4958703D	-
550183DIS	430138W	495870C2	-
550184DIS	430138W	4958703D	-
550185DIS	430138W	495870C2	-
550186DIS	430138W	4958703D	-
550187DIS	430139W	495870C2	-
550188DIS	430139W	4958703D	-
550189DIS	430140W	495870C2	-
550190DIS	430140W	4958703D	-
550191DIS	430137W	495870C2	-
550192DIS	430137W	4958703D	-
550193DIS	-	WB4.5 230V/50-60HZ	600040
550194DIS	-	WB5.0 24VDC	600040
550195DIS	-	ZB16 24VDC	600003PLUG
550196DIS	-	ZB14 230V/50-60HZ	600003PLUG
550197DIS	430089W	481865C2	600003PLUG
550198DIS	430089W	4818653D	600003PLUG
550199DIS	-	481865C2	600003PLUG
550200DIS	-	4818653D	600003PLUG
550201DIS	-	495905C2	-
550202DIS	-	495905F4	-
550203DIS	-	481865C2	600003PLUG
550204DIS	-	4818653D	600003PLUG
550205DIS	-	495905C2	-
550206DIS	-	495905F4	-
550207DIS	430135W	481865C2	600003PLUG
550208DIS	430135W	4818653D	600003PLUG
550209DIS	430135W	481865C2	600003PLUG
550210DIS	430135W	4818653D	600003PLUG
550211DIS	-	495870C2	-
550212DIS	-	4958703D	-
550213DIS	-	495870C2	-
550214DIS	-	4958703D	-
550215DIS	430096W	481865C2	600003PLUG
550216DIS	430096W	4818653D	600003PLUG
550217DIS	430136W	481865C2	600003PLUG
550218DIS	430136W	4818653D	600003PLUG
E121K03-2995-4818653D	-	4818653D	600003PLUG
E121K03-2995-481865C2	-	481865C2	600003PLUG

Solenoid Valve	Repair Kit	Spare Coil	DIN Plug
E121K03-2995-4958703D	-	4958703D	-
E121K03-2995-495870C2	-	495870C2	-
E121K03-495905C2	-	495905C2	-
E121K03-495905F4	-	495905F4	-
E121K0302-2995-4818653D	-	4818653D	600003PLUG
E121K0302-2995-481865C2	-	481865C2	600003PLUG
E121K0302-2995-4958703D	-	4958703D	-
E121K0302-2995-495870C2	-	495870C2	-
E121K0302-495905C2	-	495905C2	-
E121K0302-495905F4	-	495905F4	-
E121K0352-2995-4818653D	-	4818653D	600003PLUG
E121K0352-2995-481865C2	-	481865C2	600003PLUG
E121K0352-2995-4958703D	-	4958703D	-
E121K0352-2995-495870C2	-	495870C2	-
E121K0352-495905C2	-	495905C2	-
E121K0352-495905F4	-	495905F4	-
E121K04-2995-4818653D	-	4818653D	600003PLUG
E121K04-2995-481865C2	-	481865C2	600003PLUG
E121K04-2995-4958703D	-	4958703D	-
E121K04-2995-495870C2	-	495870C2	-
E121K04-495905C2	-	495905C2	-
E121K04-495905F4	-	495905F4	-
E121K45-2995-4818653D	-	4818653D	600003PLUG
E121K45-2995-481865C2	-	481865C2	600003PLUG
E121K45-2995-4958703D	-	4958703D	-
E121K45-2995-495870C2	-	495870C2	-
E121K45-495905C2	-	495905C2	-
E121K45-495905F4	-	495905F4	-
E121K46-2995-4818653D	-	4818653D	600003PLUG
E121K46-2995-481865C2	-	481865C2	600003PLUG
E121K46-2995-492425C2	-	492425C2	600003PLUG
E121K46-2995-492425F4	-	492425F4	600003PLUG
E121K46-2995-4958703D	-	4958703D	-
E121K46-2995-495870C2	-	495870C2	-
E121K46-495905C2	-	495905C2	-
E121K46-495905F4	-	495905F4	-
E121K63-2995-4818653D	-	4818653D	600003PLUG
E121K63-2995-481865C2	-	481865C2	600003PLUG
E121K63-2995-4958703D	-	4958703D	-
E121K63-2995-495870C2	-	495870C2	-
E121K63-495905C2	-	495905C2	-
E121K63-495905F4	-	495905F4	-
E121K64-2995-4818653D	-	4818653D	600003PLUG
E121K64-2995-481865C2	-	481865C2	600003PLUG
E121K64-2995-4958703D	-	4958703D	-
E121K64-2995-495870C2	-	495870C2	-
E121K64-495905C2	-	495905C2	-
E121K64-495905F4	-	495905F4	-
E121K65-2995-4818653D	-	4818653D	600003PLUG
E121K65-2995-481865C2	-	481865C2	600003PLUG
E121K65-2995-4958703D	-	4958703D	-
E121K65-2995-495870C2	-	495870C2	-
E121K65-495905C2	-	495905C2	-
E121K65-495905F4	-	495905F4	-
E131K03-2995-4818653D	-	4818653D	600003PLUG
E131K03-2995-481865C2	-	481865C2	600003PLUG
E131K03-2995-4958703D	-	4958703D	-
E131K03-2995-495870C2	-	495870C2	-



LIST OF REPAIR KITS, SPARE COILS, DIN PLUGS

Solenoid Valve	Repair Kit	Spare Coil	DIN Plug
E131K03-495905C2	-	495905C2	-
E131K03-495905F4	-	495905F4	-
E131K0350-2995-4818653D	-	4818653D	600003PLUG
E131K0350-2995-481865C2	-	481865C2	600003PLUG
E131K0350-2995-4958703D	-	4958703D	-
E131K0350-2995-495870C2	-	495870C2	-
E131K0350-495905C2	-	495905C2	-
E131K0350-495905F4	-	495905F4	-
E131K04-2995-4818653D	-	4818653D	600003PLUG
E131K04-2995-481865C2	-	481865C2	600003PLUG
E131K04-2995-4958703D	-	4958703D	-
E131K04-2995-495870C2	-	495870C2	-
E131K04-495905C2	-	495905C2	-
E131K04-495905F4	-	495905F4	-
E131K0450-2995-4818653D	-	4818653D	600003PLUG
E131K0450-2995-481865C2	-	481865C2	600003PLUG
E131K0450-2995-4958703D	-	4958703D	-
E131K0450-2995-495870C2	-	495870C2	-
E131K0450-495905C2	-	495905C2	-
E131K0450-495905F4	-	495905F4	-
E131K06-2995-4818653D	-	4818653D	600003PLUG
E131K06-2995-481865C2	-	481865C2	600003PLUG
E131K06-2995-4958703D	-	4958703D	-
E131K06-2995-495870C2	-	495870C2	-
E131K06-495905C2	-	495905C2	-
E131K06-495905F4	-	495905F4	-
E131K0650-2995-4818653D	-	4818653D	600003PLUG
E131K0650-2995-481865C2	-	481865C2	600003PLUG
E131K0650-2995-495870C2	-	495870C2	-
E131K0650-2995-495870F4	-	495870F4	-
E131K0650-495905C2	-	495905C2	-
E131K0650-495905F4	-	495905F4	-
E131K13-2995-4818653D	-	4818653D	600003PLUG
E131K13-2995-481865C2	-	481865C2	600003PLUG
E131K13-2995-4958703D	-	4958703D	-
E131K13-2995-495870C2	-	495870C2	-
E131K13-495905C2	-	495905C2	-
E131K13-495905F4	-	495905F4	-
E133K05-2995-4818653D	-	4818653D	600003PLUG
E133K05-2995-481865C2	-	481865C2	600003PLUG
E133K05-2995-4958703D	-	4958703D	-
E133K05-2995-495870C2	-	495870C2	-
E133K05-495905C2	-	495905C2	-
E133K05-495905F4	-	495905F4	-
E133K06-2995-4818653D	-	4818653D	600003PLUG
E133K06-2995-481865C2	-	481865C2	600003PLUG
E133K06-2995-4958703D	-	4958703D	-
E133K06-2995-495870C2	-	495870C2	-
E133K06-495905C2	-	495905C2	-
E133K06-495905F4	-	495905F4	-
E321H11-2995-4818653D	481203018	4818653D	600003PLUG
E321H11-2995-481865C2	481203018	481865C2	600003PLUG
E321H11-2995-4958703D	481203018	4958703D	-
E321H11-2995-495870C2	481203018	495870C2	-
E321H11-495905C2	481203018	495905C2	-
E321H11-495905F4	481203018	495905F4	-
E321H13-2995-4818653D	481203018	4818653D	600003PLUG
E321H13-2995-481865C2	481203018	481865C2	600003PLUG

Solenoid Valve	Repair Kit	Spare Coil	DIN Plug
E321H13-2995-4958703D	481203018	4958703D	-
E321H13-2995-495870C2	481203018	495870C2	-
E321H13-495905C2	481203018	495905C2	-
E321H13-495905F4	481203018	495905F4	-
E321H15-2995-4818653D	481203018	4818653D	600003PLUG
E321H15-2995-481865C2	481203018	481865C2	600003PLUG
E321H15-2995-492425C2	481203018	492425C2	600003PLUG
E321H15-2995-4958703D	481203018	4958703D	-
E321H15-2995-495870C2	481203018	495870C2	-
E321H15-495905C2	481203018	495905C2	-
E321H15-495905F4	481203018	495905F4	-
E321K10-2995-4818653D	481203175	4818653D	600003PLUG
E321K10-2995-481865C2	481203175	481865C2	600003PLUG
E321K10-2995-4958703D	481203175	4958703D	-
E321K10-2995-495870C2	481203175	495870C2	-
E321K10-495905C2	481203175	495905C2	-
E321K10-495905F4	481203175	495905F4	-
E321K13-2995-4818653D	481203175	4818653D	600003PLUG
E321K13-2995-481865C2	481203175	481865C2	600003PLUG
E321K13-2995-4958703D	481203175	4958703D	-
E321K13-2995-495870C2	481203175	495870C2	-
E321K13-495905C2	481203175	495905C2	-
E321K13-495905F4	481203175	495905F4	-
E321K15-2995-4818653D	481203175	4818653D	600003PLUG
E321K15-2995-481865C2	481203175	481865C2	600003PLUG
E321K15-2995-492425C2	481203175	492425C2	600003PLUG
E321K15-2995-4958703D	481203175	4958703D	-
E321K15-2995-495870C2	481203175	495870C2	-
E321K15-495905C2	481203175	495905C2	-
E321K15-495905F4	481203175	495905F4	-
PA10C1G3R032S	-	-	-
PA10C2G3R032S	-	-	-
PA10S1G3R050S	-	-	-
PA10S2G3R050S	-	-	-
PA10SAG3R050S	-	-	-
PA15C1G4R032S	-	-	-
PA15C2G4R032S	-	-	-
PA15S1G4R040S	-	-	-
PA15S1G4R050A	-	-	-
PA15S1G4R050S	-	-	-
PA15S2G4R050S	-	-	-
PA15SAG4R050A	-	-	-
PA15SAG4R050S	-	-	-
PA20C1G5R032S	-	-	-
PA20C2G5R032S	-	-	-
PA20S1G5R050A	-	-	-
PA20S1G5R050S	-	-	-
PA20S2G5R050S	-	-	-
PA20SAG5R050A	-	-	-
PA20SAG5R050S	-	-	-
PA25S1G6R050S	-	-	-
PA25S1G6R063S	-	-	-
PA25S2G6R063S	-	-	-
PA25SAG6R063A	-	-	-
PA25SAG6R063S	-	-	-
PA32S1G7R063S	-	-	-
PA32S2G7R063S	-	-	-
PA32SAG7R080S	-	-	-

SPARE PARTS
Repair Kits, Coils & Plugs



COILS FOR DIN PLUG CONNECTION



481865 - COILS 32 mm

This is an encapsulated assembly comprising a coil, integral magnetic iron path and snap-on plug connection.

The synthetic material encapsulation provides an effective compact housing, offering full protection against dust, oil, water, etc.

Ease of mounting in confined space - offers shock and corrosion protection - simplifies conversion of existing equipment to other requirements, etc.

Coils conform to the IEC/CENELEC safety standards and complies with European low-voltage directive.

DIN plug connector to be ordered separately.



DIN plug to be ordered separately

Specification		Standard			
Reference (without DIN plug)		481865			
Degree of protection		IP65 according to IEC / EN 60529 standards (with DIN plug).			
Class of insulation		F 155°C			
Electrical connection		The coil is connected with a 2 P + E plug according to EN 175301-803 type A			
Ambient temperature		-40°C to +50°C The application is limited also by the temperature range of the valve.			
Electrical Power	DC	Pn (hot)	9 W		
		P (cold) 20°C	12 W		
AC		Pn (holding)	8 W		
		Attraction cold	26 VA (9 W)		
Weight		130 g (without plug)			
Voltages "Un"		VAC/Hz	Code	VDC	Code
-10% to +10% of the Un		220-230/50	3D	24	C2

To Order a Coil choose Coil Ref + Voltage Code, example: 481865 for 24 VDC = 481865C2

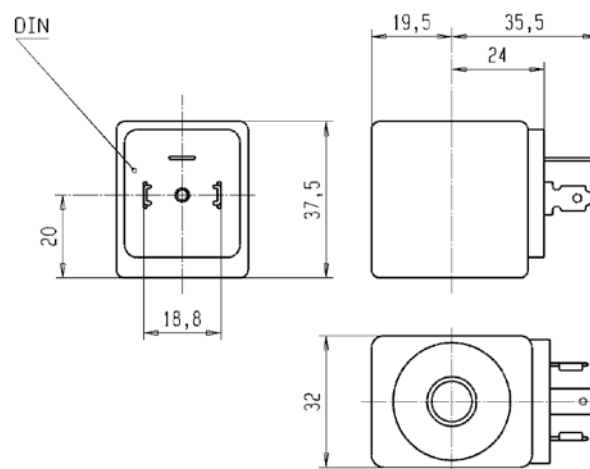

COILS FOR DIN PLUG CONNECTION



492425 - HIGH TEMPERATURE COILS 32 mm

This is an encapsulated assembly comprising a coil, integral magnetic iron path and snap-on plug connection.

The synthetic material encapsulation provides an effective compact housing, offering full protection against dust, oil, water, etc.

Ease of mounting in confined space - offers shock and corrosion protection - simplifies conversion of existing equipment to other requirements, etc.

Coils conform to the IEC/CENELEC safety standards and complies with European low-voltage directive.

DIN plug connector to be ordered separately.



DIN plug to be ordered separately

Specification		High temperature + High power			
Reference (without DIN plug)		492425			
Degree of protection		IP65 according to IEC / EN 60529 standards (with DIN plug).			
Class of insulation		H 180°C			
Electrical connection		The coil is connected with a 2 P + E plug according to EN 175301-803 type A			
Ambient temperature		-40°C to +50°C The application is limited also by the temperature range of the valve.			
Electrical Power	DC	Pn (hot)	14 W		
		P (cold) 20°C	21 W		
AC		Pn (holding)	14 W		
		Attraction cold	55 VA (18 W)		
Weight		130 g (without plug)			
Voltages "Un" -10% to +10% of the Un		VAC/Hz	Code	VDC	Code
		230/50	F4	24	C2

To Order a Coil choose Coil Ref + Voltage Code, example: 492425 for 24 VDC= 492425C2

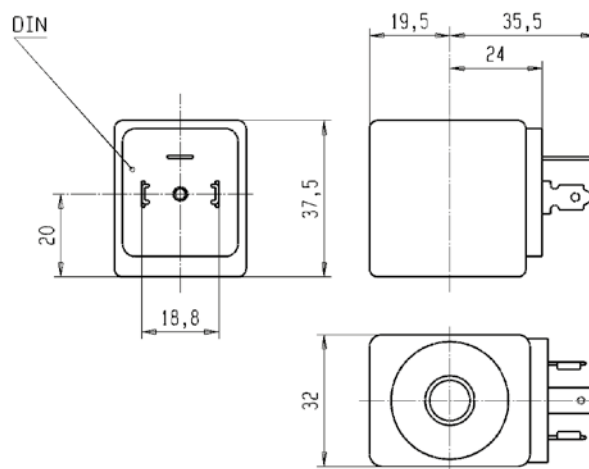

SPARE PARTS
Repair Kits, Coils & Plugs



COILS FOR DIN PLUG CONNECTION



488980 - COILS 22 mm

This coil is designed for valves equipped with a miniature tube assembly. This is an encapsulated assembly comprising a coil, integral magnetic iron path and snap-on plug connection.

The synthetic material encapsulation provides an effective compact housing, offering full protection against dust, oil, water, etc.

Ease of mounting in confined space - offers shock and corrosion protection - simplifies conversion of existing equipment to other requirements, etc.

Coil conforms to the IEC/CENELEC safety standards and complies with European low-voltage directive.

DIN plug connector to be ordered separately.



DIN plug to be ordered separately

Specification		Low power			
Reference (without DIN plug)		488980			
Degree of protection		IP65 according to IEC / EN 60529 standards (with DIN plug).			
Class of insulation		F 155°C			
Electrical connection		The coil is connected with a 2 P + E plug according to EN 175301-803 type B.			
Ambient temperature		-40°C to +50°C The application is limited also by the temperature range of the valve.			
Electrical Power	DC	Pn (hot)	2.5 W		
		P (cold) 20°C	3 W		
AC		Pn (holding)	2 W		
		Attraction cold	5.7 VA (2.5 W)		
Weight		100 g with DIN Plug			
Voltages "Un"		VAC/Hz	Code	VDC	Code
-10% to +10% of the Un		220/50-230/50	3D	24	C2

To Order a Coil choose Coil Ref + Voltage Code, example: 488980 for 24 VDC = 488980C2

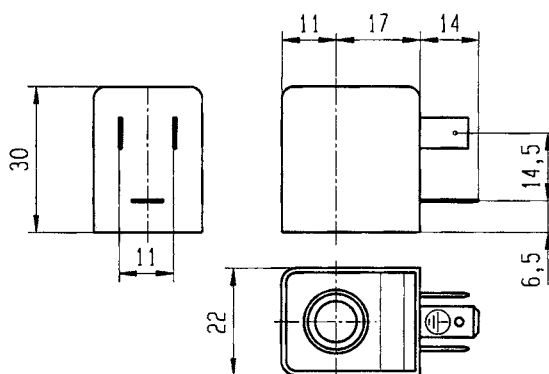

COILS FOR DIN PLUG CONNECTION



496131 - DOUBLE FREQUENCY COILS 22 mm

This coil is designed for valves equipped with a miniature tube assembly. This is an encapsulated assembly comprising a coil, integral magnetic iron path and snap-on plug connection.

The synthetic material encapsulation provides an effective compact housing, offering full protection against dust, oil, water, etc.

Ease of mounting in confined space - offers shock and corrosion protection - simplifies conversion of existing equipment to other requirements, etc.

Coil conforms to the IEC/CENELEC safety standards and complies with European low-voltage directive.

DIN plug connector to be ordered separately.



DIN plug to be ordered separately

Specification		Double frequency			
Reference (without DIN plug)		496131			
Degree of protection		IP65 according to IEC / EN 60529 standards (with DIN plug).			
Class of insulation		F 155°C			
Electrical connection		The coil is connected with a 2 P + E plug according to EN 175301-803 type B.			
Ambient temperature		-40°C to +50°C The application is limited also by the temperature range of the valve.			
Electrical Power	DC	Pn (hot)	3 W		
		P (cold) 20°C	-		
	AC	Pn (holding)	3 W		
		Attraction cold	-		
Weight		60 g			
Voltages "Un"		VAC/Hz	Code	VDC	Code
-10% to +10% of the Un		230/50-60	P9	24 V	C2

To Order a Coil choose Coil Ref + Voltage Code, example: 496131 for 24 VDC = 496131C2

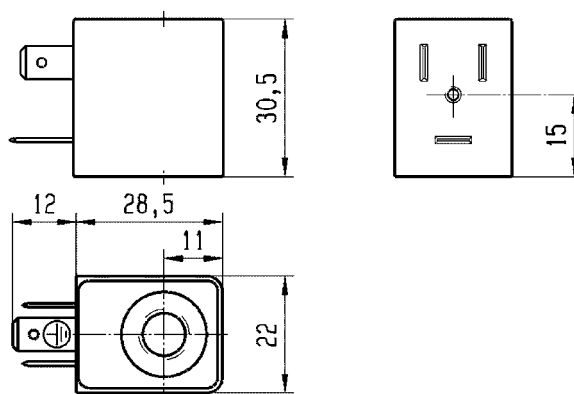

SPARE
PARTS
Repair Kits, Coils & Plugs



COILS FOR DIN PLUG CONNECTION



WB4.5 / WB5.0 - COILS SERIES 22 mm

Coil manufactured with H class copper wire, moulded in thermoplastic material polyester with 30% glass fiber. IP65 protection rate with DIN 43650A three pin connector and appropriate gasket.

The synthetic material encapsulation provides an effective compact housing, offering full protection against dust, oil, water, etc. Coils conforms to the IEC/CENELEC safety standards and complies with European low-voltage directive.

DIN plug connector to be ordered separately.



DIN plug to be ordered separately

Specification		Standard			
Reference (without DIN plug)		WB4.5 for AC		WB5.0 for DC	
Degree of protection		IP65 according to IEC / EN 60529 standards (with DIN plug + gasket)			
Class of insulation		F 155°C			
Electrical connection		The coil is connected with a 2 P + E plug according to EN 175301-803 type B.			
Ambient temperature		-10°C to +50°C The application is limited also by the temperature range of the valve.			
Electrical Power	DC	P (cold) 20°C	5 W		
	AC	Pn (holding)	4.5 W		
		Attraction cold	7.5 VA		
Weight		90 g (without plug)			
Voltages "Un"		WB4.5 VAC/Hz	Order Number	WB5.0 VDC	Order Number
-10% to +10% of the Un -5% to +10% for Un DC		230/50-60	304262J	24	302654

To Order a Coil: Use 6 digits ordering number - Code Example: WB4.5 for 230/50-60 = 304262J

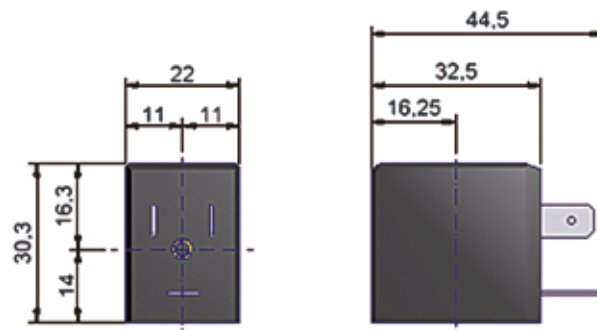

COILS FOR DIN PLUG CONNECTION



ZB09 / ZB12 - COILS SERIES

Coil manufactured with H class copper wire, moulded in thermoplastic material polyester with 30% glass fiber. IP65 protection rate with EN 175301-803:2006-A. Three pin connector.

This coil conforms to the IEC/CENELEC safety standards and complies with European low-voltage directive.

DIN plug connector to be ordered separately.



DIN plug to be ordered separately

Specification		Standard			
Reference (without DIN plug)		ZB09 for AC		ZB12 for DC	
Degree of protection		IP65 according to IEC / EN 60529 standards (with DIN plug and gasket)			
Class of insulation		F 155°C			
Electrical connection		The coil is connected with a 2 P + E plug according to EN 175301-803 - type A			
Ambient temperature		-10°C to +50°C The application is limited also by the temperature range of the valve.			
Electrical Power	DC	P (cold) 20°C	12 W		
	AC	Pn (holding)	9 W		
		Attraction cold	25 VA		
Weight		130 g			
Voltages "Un"		ZB09 VAC/Hz	Order Number	ZB12 VDC	Order Number
-10% to +10% of the Un -5% to +10% for Un DC.		230/50-60	304012	24	304020

To Order a Coil: Use 6 digits ordering number - Code Example: ZB09 230/50-60 = 304012

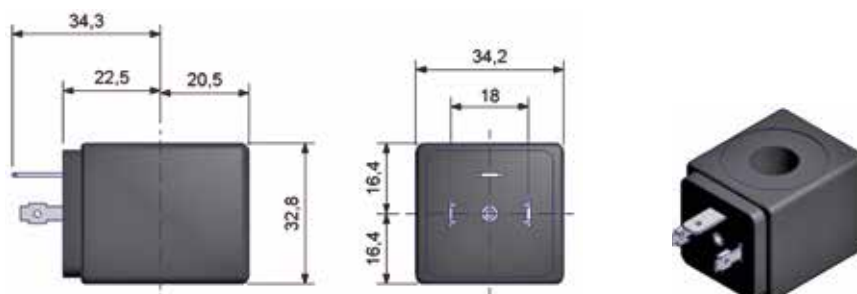

SPARE
PARTS
Repair Kits, Coils & Plugs



COILS FOR DIN PLUG CONNECTION



ZB14 / ZB16 / ZH14 / ZH16 - HIGH POWER HIGH TEMPERATURE COILS SERIES

Coil manufactured with H class copper wire, moulded in thermoplastic material polyester with 30% glass fiber.

IP65 protection rate with EN 175301-803:2006-A. Three pin connector.

This coil conforms to the IEC/CENELEC safety standards and complies with European low-voltage directive.

DIN plug connector to be ordered separately.



DIN plug to be ordered separately

Specification			High power				High temperature + high power			
Reference (without DIN plug)			ZB14 for AC		ZB16 for DC		ZH14 for AC		ZH16 for DC	
Degree of protection			IP65 according to IEC / EN 60529 standards (with DIN plug and gasket)							
Class of insulation			H 180°C							
Electrical connection			The coil is connected with a 2 P + E plug according to EN 175301-803 - type A							
Ambient temperature			-10°C to +50°C				-10°C to +80°C			
			The application is limited also by the temperature range of the valve.							
Electrical Power	DC	P (cold) 20°C	16 W							
	AC	Pn (holding)	14 W							
		Attraction cold	33 VA							
Weight			130 g (without plug)							
Voltages "Un"			ZB14 VAC/Hz	Order Number	ZB16 VDC	Order Number	ZH14 VAC/Hz	Order Number	ZH16 VDC	Order Number
-10% to +10% of the Un										
-5% to +10% for Un DC			230/50-60	304062	24	304070	230/50-60	304104	24	304112

To Order a Coil: Use 6 digits ordering number - Code Example: ZH16 for 24 VDC = 304112

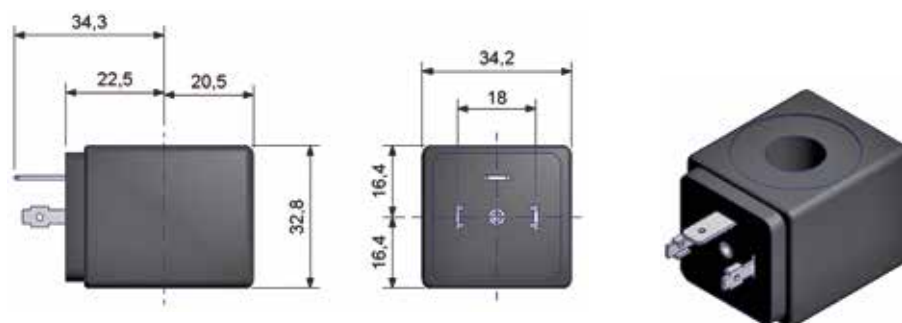

COILS FOR DIN PLUG CONNECTION



JB14 / JB16 - COILS SERIES

Coil manufactured with H class copper wire, moulded in thermoplastic material polyester with 30% glass fiber.

IP65 protection rate with EN 175301-803:2006-A. Three pin connector.

This coil conforms to the IEC/CENELEC safety standards and complies with European low-voltage directive.

DIN plug connector to be ordered separately.



DIN plug to be ordered separately

Specification		Standard			
Reference (without DIN plug)		JB14 for AC		JB16 for DC	
Degree of protection		IP65 according to IEC / EN 60529 standards (with DIN plug and gasket)			
Class of insulation		F 155°C			
Electrical connection		The coil is connected with a 2 P + E plug according to EN 175301-803 - Type A			
Ambient temperature		-10°C to +50°C The application is limited also by the temperature range of the valve.			
Electrical Power	DC	P (cold) 20°C	16 W		
	AC	Pn (holding)	14 W		
		Attraction cold	55 VA		
Weight		130 g (without plug)			
Voltages "Un" -10% to +10% of the Un -5% to +10% for Un DC.		JB14 VAC/Hz	Order Number	JB16 VDC	Order Number
		230/50-60	304915	24	304950

To Order a Coil: Use 6 digits ordering number - Code Example: JB14 for 230/50-60 = 304915

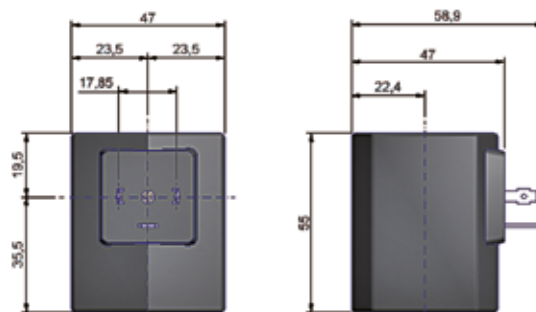

SPARE
PARTS
Repair Kits, Coils & Plugs



COILS FOR DIN PLUG CONNECTION



D4 - UL COILS SERIES 32 mm

This coil is UL-approved as a recognized component for the insulation Class 155, conforms to the IEC/CENELEC safety standards and complies with European low-voltage directive.

DIN plug connector to be ordered separately.



DIN plug to be ordered separately

Specification		UL Recognized			
Reference (without DIN plug)		D4 Series			
Degree of protection		IP65 according to IEC / EN 60529 standards (with DIN plug)			
Class of insulation		F 155°C			
Electrical connection		The coil is connected with a 2 P + E plug according to EN 175301-803 type A			
Ambient temperature		-40°C to +50°C The application is limited also by the temperature range of the valve.			
Electrical Power	DC	Pn (hot)	12 W		
		P (cold) 20°C	16 W		
	AC	Pn (holding)	11 W		
		Attraction cold	13 VA		
Weight		130 g			
Voltages "Un"		VAC/Hz	Code	VDC	Code
-10% to +10% of Un for AC		220/50 - 240/60	D4G	24	D4B
-5 % to +10 % for Un DC					

To Order a Coil: Use 6 digits ordering number - Code Example: D4 for 220/50 - 240/60 = D4G

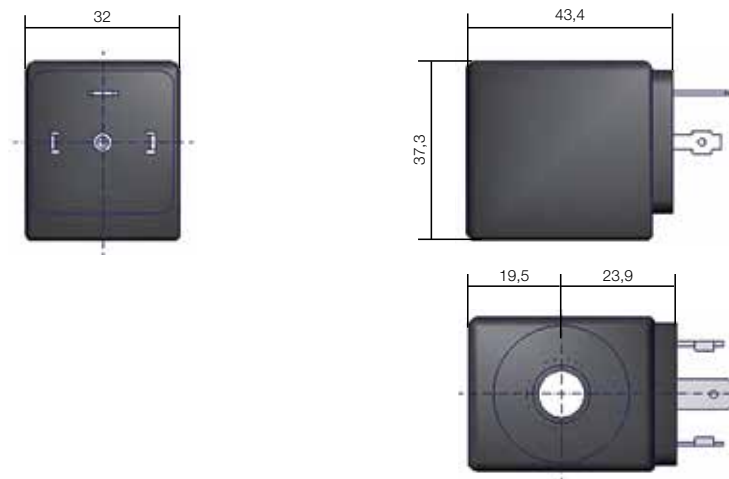

All dimensions are in mm



COILS FOR DIN PLUG CONNECTION



D5 - COILS SERIES 32 mm

Encapsulated in synthetic material, Connector for 2P+E according with DIN EN 175301-803, Form A, IP65 degree of protection to be considered with connector plug only.

This coil conforms to the IEC/CENELEC safety standards and complies with European low-voltage directive.

DIN plug connector to be ordered separately.



DIN plug to be ordered separately

Specification		Mono Frequency VDE Coil			
Reference (without DIN plug)		D5 Series			
Degree of protection		IP65 according to IEC / EN 60529 standards (with DIN plug)			
Class of insulation		F 155°C			
Electrical connection		The coil is connected with a 2 P + E plug according to EN 175301-803 type A.			
Ambient temperature		-40°C to +50°C The application is limited also by the temperature range of the valve.			
Electrical Power	DC	Pn (hot)	9 W		
		P (cold) 20°C	-		
	AC	Pn (holding)	8 W		
		Attraction cold	26 VA		
Weight		130 g			
Voltages "Un"		VAC/Hz	Code	VDC	Code
-10% to +10% of Un for AC		220-230/50	D5L	24	D5B
-5 % to +10 % for Un DC					

To Order a Coil: Use 6 digits ordering number - Code Example: D5 for 220-230/50 = D5L

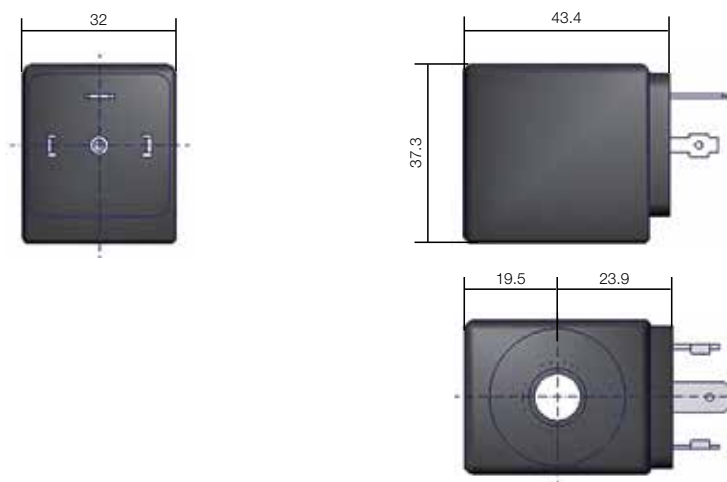

All dimensions are in mm



COILS FOR DIN PLUG CONNECTION



DG - COILS SERIES 22 mm

This coil is designed for valves equipped with a miniature tube assembly. This is an encapsulated assembly comprising a coil, integral magnetic iron path and snap-on plug connection.

The synthetic material encapsulation provides an effective compact housing, offering full protection against dust, oil, water, etc.

Ease of mounting in confined space - offers shock and corrosion protection - simplifies conversion of existing equipment to other requirements, etc.

Coil conforms to the IEC/CENELEC safety standards and complies with 2006/95/EC European low-voltage directive.

DIN plug connector to be ordered separately.



DIN plug to be ordered separately

Specification		High power			
Reference (without DIN plug)		DG			
Degree of protection		IP65 according to IEC / EN 60529 standards (with DIN plug).			
Class of insulation		F 155°C			
Electrical connection		The coil is connected with a 2 P + E plug according to EN 175301-803 type B.			
Ambient temperature		-40°C to +50°C The application is limited also by the temperature range of the valve.			
Electrical Power	DC	Pn (hot)	5 W		
		P (cold) 20°C	6.5 W		
	AC	Pn (holding)	4 W		
		Attraction cold	8.9 VA (5 W)		
Weight		100 g			
Voltages "Un" -10% to +10% of the Un		VAC/Hz	Code	VDC	Code
		220/50-230/50	L	24	B

To Order a Coil choose Coil Ref + Voltage Code, example: DG for 24VDC = DGB

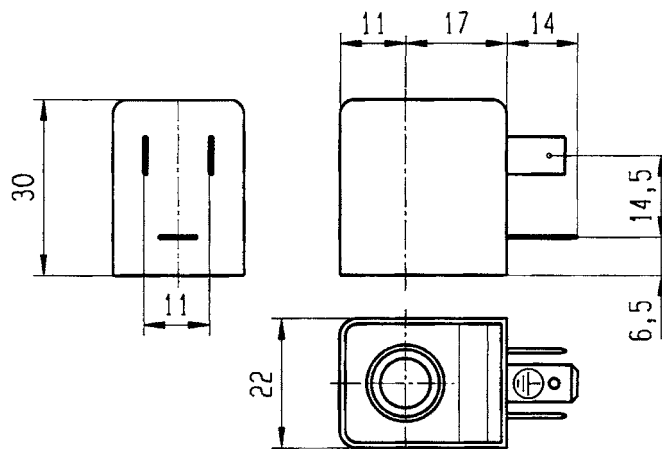

All dimensions are in mm



ZONE 2/22

495865 - ELECTRICAL PART LOW POWER 22 mm

Application:

Control of solenoid valves in dangerous areas where explosion-proof protection Ex nAc nCc IIC T5 is required.

Benefits:

The synthetic material encapsulation of the coil provides an effective compact housing, offering full protection against dust, oil, water, etc.

Small size for ease of mounting in confined spaces.

Coil delivered with DIN plug.



Coil delivered with DIN plug

Reference (with DIN plug)		495865			
Certificate		LCIE 05 ATEX 6003 X			
Type of protection	Gas	II 3 G Ex nAc nCc IIC T5			
	Dust	II 3 D - Ex tc IIIC - T 95°C			
Degree of protection		IP65 (with plug) according to IEC/EN 60529 Standards			
Class of insulation		F 155°C			
Electrical connection		These coils with connection 2P + G - when mounted together with the supplied Pg 9 plug (delivered with the coil),			
Ambient temperature		-40°C to +50°C The application is limited also by the temperature range of the valve.			
Electrical Power	DC	Pn (hot)	2.5 W		
		P (cold) 20°C	3 W		
	AC	Pn (holding)	2 W		
		Attraction cold	5.7 VA (2.5 W)		
Weight		120 g			
Voltages "Un" -10% to +10% of the Un		VAC/Hz	Code	VDC	Code
		220/50-230/50	3D	24	C2

To Order a Coil choose Coil Ref + Voltage Code, example: 495865 for 24 VDC = **495865C2**

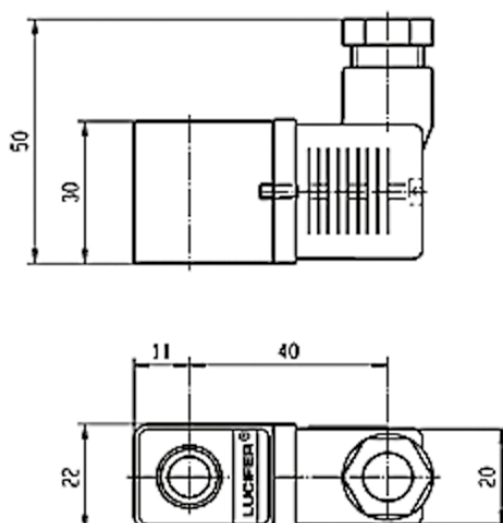

All dimensions are in mm

ZONE 2/22

496637 - ELECTRICAL PART DOUBLE FREQUENCY 22 mm

Application:

Control of solenoid valves in dangerous areas where explosion-proof protection Ex nAc nCc IIC T5 is required.

Benefits:

The synthetic material encapsulation of the coil provides an effective compact housing, offering full protection against dust, oil, water, etc.

Small size for ease of mounting in confined spaces.

Coil delivered with DIN plug.



Coil delivered with DIN plug

Specification		Double Frequency			
Reference (with DIN plug)		496637			
Certificate		ATEX			
Type of protection	Gas	Ex nAc nCc IIC T5			
	Dust	II 3 D - Ex tc IIIC - T 95°C			
Degree of protection		IP65 (with plug) according to IEC/EN 60529 Sandards			
Class of insulation		F 155°C			
Ambient temperature		-20°C to +50°C The application is limited also by the temperature range of the valve.			
Electrical Power	DC	Pn (hot)	3 W		
		P (cold) 20°C	-		
	AC	Pn (holding)	3 W		
		Attraction cold	5.7 VA (2.5 W)		
Weight		75 g			
Voltages "Un" -10% to +10% of the Un		VAC/Hz	Code	VDC	Code
		230/50-60	P9	24	C2

To Order a Coil choose Coil Ref + Voltage Code, example: 496637 for 24 VDC = 496637C2

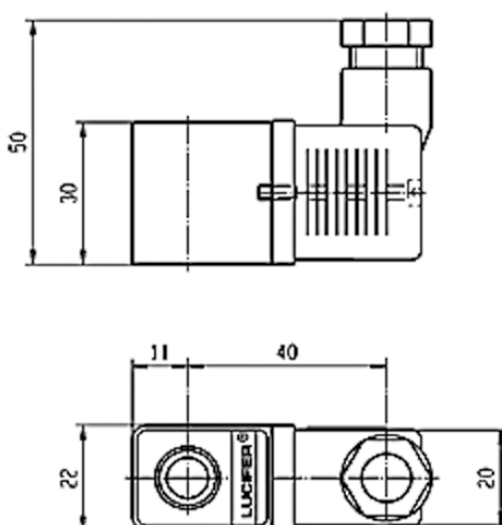

All dimensions are in mm



ZONE 2/22

495870 - ELECTRICAL PART 32 mm

Application:

Control of solenoid valves in dangerous areas where explosion-proof protection Ex nAc nCc IIC T3/T4 is required.

Ease of mounting in confined space - offers shock and corrosion protection - simplifies conversion of existing equipment to other requirements, etc.

Benefits:

The synthetic material encapsulation of the coil provides an effective compact housing, offering full protection against dust, oil, water, etc.

Small size for ease of mounting in confined spaces.

Coil delivered with DIN plug.



Coil delivered with DIN plug

Reference (with DIN plug)		495870			
Certificate		LCIE 05 ATEX 6003 X			
Type of protection	Gas	II 3 G Ex nAc nCc IIC T3/T4			
	Dust	II 3 D - Ex tc IIIC - T195°C / T130°C			
Degree of protection		IP65 (with plug) according to IEC/EN 60529 Standards			
Class of insulation		F 155°C			
Duty cycle		100%			
Ambient temperature		-40°C to +65°C / 50°C The application is limited also by the temperature range of the valve.			
Electrical Power	DC	Pn (hot)	9 W		
		P (cold) 20°C	12 W		
	AC	Pn (holding)	8 W		
		Attraction cold	26 VA (9 W)		
Weight		150 g			
Voltages "Un" -10% to +10% of the Un		VAC/Hz	Code	VDC	Code
		220-230/50	3D	24	C2

To Order a Coil choose Coil Ref + Voltage Code, example: 495870 for 24 VDC = 495870C2

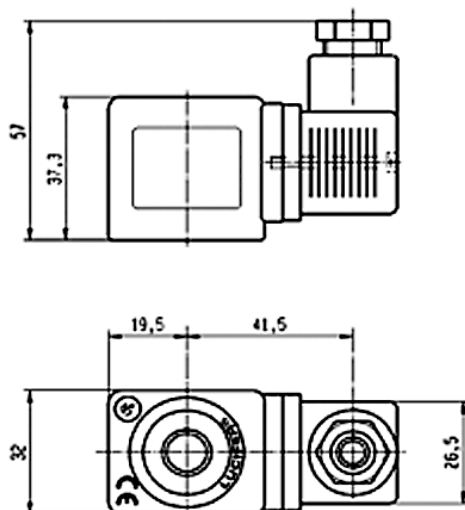

All dimensions are in mm



ENCAPSULATED ELECTRICAL PARTS "mb"



ZONE 1/21

482605 / 482606 - ELECTRICAL PART LOW POWER 22 mm

Application:

Control of solenoid valves in dangerous areas where explosion-proof protection Ex mb IIC T4 / T5 is required.

Benefits:

Coil and magnetic circuit encapsulated in synthetic material - offering shock and corrosion protection. AC coils with integrated thermal fuse.

Small size for ease of mounting in confined spaces.

Coil delivered with DIN plug.



Coil delivered with DIN plug

Reference (with DIN plug)		482605	482606				
Certificate		LCIE 02 ATEX 6014 X - IECEx LCI 07.0026 X					
Type of protection	Gas	II 2 G - Ex mb IIC T4 / T5					
	Dust	II 2 D - Ex tb IIIC - T130°C / 95°C					
Degree of protection		IP65 (with plug) according to IEC/EN 60529 Standards					
Class of insulation		F 155°C					
Electrical connection		Cable connection (3 x 0.75 mm ²) encapsulated with coil, cable material according to application					
Ambient temperature		-40°C to +65°C / +40°C The application is limited also by the temperature range of the valve.					
Electrical Power	DC	Pn (hot)	5 W	2.5 W			
		P (cold) 20°C	6.5 W	3 W			
	AC	Pn (holding)	4 W	2 W			
		Attraction cold	8.9 VA (5 W)	5.7 VA (2.5 W)			
Weight		150 g					
Voltages "Un"		VDC	Code	VAC/Hz	Code	VDC	Code
-10% to +10% of the Un		24	C2	220/50-230/50	3D	24	C2

To Order a Coil choose Coil Ref + Voltage Code, example: 482605 for 24 VDC = 482605C2

* 482606 - 1.5 m cable length

Fuses:

Both electrical parts 482605 & 482606 have to be connected in series with a safety fuse according to CEI 60127-3. Indicating example below:

482605:

DC: 24 V, 500 mA

482606:

DC: 24 V, 200 mA
AC 50 HZ: 220/230 V, 32 mA

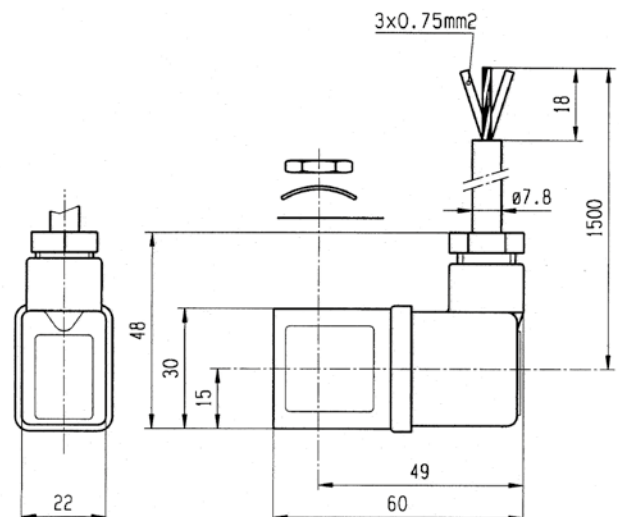

All dimensions are in mm



FLAME PROOF ENCAPSULATED ELECTRICAL PARTS "db mb"



ZONE 1/21

495905 - ELECTRICAL PARTS 37 mm

Application:

Control of solenoid valves in dangerous areas where explosion-proof protection Ex db mb IIC T4 is required.

Benefits:

Rotatable 360° fibreglass-reinforced plastic housing (class H). Solenoid coil, rectifier (silicium diodes), fuses and varistor protection are completely encapsulated into the coil housing by epoxy resin for shock and corrosion protection.

The plastic housing is delivered with M20 x 1.5 cable gland certified for use "db" protection. Small size for ease of mounting in confined space.



Reference	495905			
Certificate	LCIE 03 ATEX 6451 X - IECEx LCI 06.0004 X			
Type of protection	Gas	II 2 G - Ex db mb IIC T4		
	Dust	II 2 D - Ex tb IIIC - 130°C		
Degree of protection	IP67 according to IEC/EN 60529 Standards			
Class of insulation	H 180°			
Electrical connection	Electric connection is done in the connection box on an easily accessible connector terminals. The introduction of the cable (Ø min 5 mm, Ømax. 11 mm, section max. 2.5 mm²) in the connection box passes by the built in M20 x 1.5 cable gland.			
Ambient temperature	-40°C to +80°C The application is limited also by the temperature range of the valve.			
Electrical Power	DC	Pn (hot)	8 W	
		P (cold) 20°C	9 W	
	AC	Pn (holding)	8 W	
		Attraction cold	9 W	
Voltages "Un" -10% to +10% of the Un	VAC/Hz	Code	VDC	Code
	230/50	F4	24	C2

To Order a Coil choose Coil Ref + Voltage Code, example: 495905 for 24 VDC = 495905C2

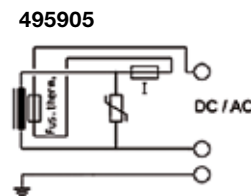
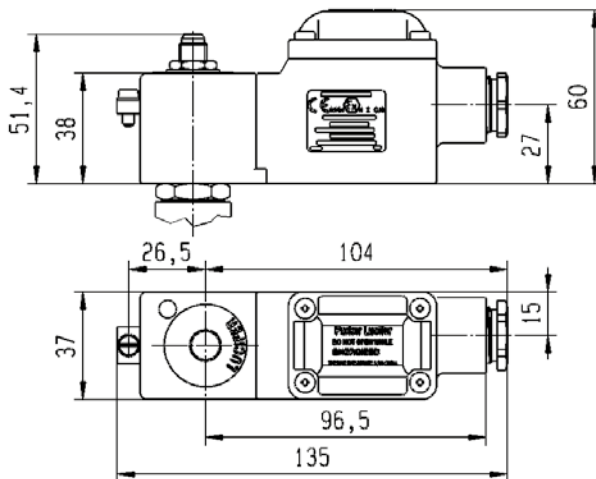

All dimensions are in mm



MORE VOLTAGES

Solenoid Valve	Voltage	ATEX	48 Vdc	24 V / 50 Hz	110 V / 50 Hz
121K01-2995-4818653D	220-230/50 HZ	NON ATEX	121K01-2995-481865C4	121K01-2995-481865A2	121K01-2995-481865A5
121K01-2995-481865C2	24 VDC	NON ATEX	121K01-2995-481865C4	121K01-2995-481865A2	121K01-2995-481865A5
121K01-2995-492425C2	24 VDC	NON ATEX	-	121K01-2995-492425A2	-
121K01-2995-4958703D	220-230/50 HZ	2-22	121K01-2995-495870C4	121K01-2995-495870A2	121K01-2995-495870A5
121K01-2995-495870C2	24 VDC	2-22	121K01-2995-495870C4	121K01-2995-495870A2	121K01-2995-495870A5
121K01-495905C2	24 VDC	1-21	121K01-495905C4	121K01-495905A2	-
121K01-495905F4	230/50 HZ	1-21	121K01-495905C4	121K01-495905A2	-
121K02-2995-4818653D	220-230/50 HZ	NON ATEX	121K02-2995-481865C4	121K02-2995-481865A2	121K02-2995-481865A5
121K02-2995-481865C2	24 VDC	NON ATEX	121K02-2995-481865C4	121K02-2995-481865A2	121K02-2995-481865A5
121K02-2995-492425C2	24 VDC	NON ATEX	-	121K02-2995-492425A2	-
121K02-2995-492425F4	230/50 HZ	NON ATEX	-	121K02-2995-492425A2	-
121K02-2995-4958703D	220-230/50 HZ	2-22	121K02-2995-495870C4	121K02-2995-495870A2	121K02-2995-495870A5
121K02-2995-495870C2	24 VDC	2-22	121K02-2995-495870C4	121K02-2995-495870A2	121K02-2995-495870A5
121K02-495905C2	24 VDC	1-21	121K02-495905C4	121K02-495905A2	-
121K02-495905F4	230/50 HZ	1-21	121K02-495905C4	121K02-495905A2	-
121K0250-2995-4818653D	220-230/50 HZ	NON ATEX	121K0250-2995-481865C4	121K0250-2995-481865A2	121K0250-2995-481865A5
121K0250-2995-481865C2	24 VDC	NON ATEX	121K0250-2995-481865C4	121K0250-2995-481865A2	121K0250-2995-481865A5
121K0250-2995-4958703D	220-230/50 HZ	2-22	121K0250-2995-495870C4	121K0250-2995-495870A2	121K0250-2995-495870A5
121K0250-2995-495870C2	24 VDC	2-22	121K0250-2995-495870C4	121K0250-2995-495870A2	121K0250-2995-495870A5
121K0250-495905C2	24 VDC	1-21	121K0250-495905C4	121K0250-495905A2	-
121K0250-495905F4	230/50 HZ	1-21	121K0250-495905C4	121K0250-495905A2	-
121K0706-2995-4818653D	220-230/50 HZ	NON ATEX	121K0706-2995-481865C4	121K0706-2995-481865A2	121K0706-2995-481865A5
121K0706-2995-481865C2	24 VDC	NON ATEX	121K0706-2995-481865C4	121K0706-2995-481865A2	121K0706-2995-481865A5
121K0706-2995-492425C2	24 VDC	NON ATEX	-	121K0706-2995-492425A2	-
121K0706-2995-4958703D	220-230/50 HZ	2-22	121K0706-2995-495870C4	121K0706-2995-495870A2	121K0706-2995-495870A5
121K0706-2995-495870C2	24 VDC	2-22	121K0706-2995-495870C4	121K0706-2995-495870A2	121K0706-2995-495870A5
121K0706-495905C2	24 VDC	1-21	121K0706-495905C4	121K0706-495905A2	-
121K0706-495905F4	230/50 HZ	1-21	121K0706-495905C4	121K0706-495905A2	-
121K3106-2995-4818653D	220-230/50 HZ	NON ATEX	121K3106-2995-481865C4	121K3106-2995-481865A2	121K3106-2995-481865A5
121K3106-2995-481865C2	24 VDC	NON ATEX	121K3106-2995-481865C4	121K3106-2995-481865A2	121K3106-2995-481865A5
121K3106-2995-492425C2	24 VDC	NON ATEX	-	121K3106-2995-492425A2	-
121K3106-2995-4958703D	220-230/50 HZ	2-22	121K3106-2995-495870C4	121K3106-2995-495870A2	121K3106-2995-495870A5
121K3106-2995-495870C2	24 VDC	2-22	121K3106-2995-495870C4	121K3106-2995-495870A2	121K3106-2995-495870A5
121K3106-495905C2	24 VDC	1-21	121K3106-495905C4	121K3106-495905A2	-
121K3106-495905F4	230/50 HZ	1-21	121K3106-495905C4	121K3106-495905A2	-
121K3306-2995-4818653D	220-230/50 HZ	NON ATEX	121K3306-2995-481865C4	121K3306-2995-481865A2	121K3306-2995-481865A5
121K3306-2995-481865C2	24 VDC	NON ATEX	121K3306-2995-481865C4	121K3306-2995-481865A2	121K3306-2995-481865A5
121K3306-2995-492425C2	24 VDC	NON ATEX	-	121K3306-2995-492425A2	-
121K3306-2995-492425F4	230/50 HZ	NON ATEX	-	121K3306-2995-492425A2	-
121K3306-2995-4958703D	220-230/50 HZ	2-22	121K3306-2995-495870C4	121K3306-2995-495870A2	121K3306-2995-495870A5
121K3306-2995-495870C2	24 VDC	2-22	121K3306-2995-495870C4	121K3306-2995-495870A2	121K3306-2995-495870A5
121K3306-495905C2	24 VDC	1-21	121K3306-495905C4	121K3306-495905A2	-
121K3306-495905F4	230/50 HZ	1-21	121K3306-495905C4	121K3306-495905A2	-
121V5163-2995-4818653D	220-230/50 HZ	NON ATEX	121V5163-2995-481865C4	121V5163-2995-481865A2	121V5163-2995-481865A5
121V5163-2995-481865C2	24 VDC	NON ATEX	121V5163-2995-481865C4	121V5163-2995-481865A2	121V5163-2995-481865A5
121V5363-2995-4818653D	220-230/50 HZ	NON ATEX	121V5363-2995-481865C4	121V5363-2995-481865A2	121V5363-2995-481865A5
121V5363-2995-481865C2	24 VDC	NON ATEX	121V5363-2995-481865C4	121V5363-2995-481865A2	121V5363-2995-481865A5
121V5463-2995-4818653D	220-230/50 HZ	NON ATEX	121V5463-2995-481865C4	121V5463-2995-481865A2	121V5463-2995-481865A5
121V5463-2995-481865C2	24 VDC	NON ATEX	121V5463-2995-481865C4	121V5463-2995-481865A2	121V5463-2995-481865A5
122K83-2995-4818653D	220-230/50 HZ	NON ATEX	122K83-2995-481865C4	122K83-2995-481865A2	122K83-2995-481865A5
122K83-2995-481865C2	24 VDC	NON ATEX	122K83-2995-481865C4	122K83-2995-481865A2	122K83-2995-481865A5
122K83-2995-4958703D	220-230/50 HZ	2-22	122K83-2995-495870C4	122K83-2995-495870A2	122K83-2995-495870A5
122K83-2995-495870C2	24 VDC	2-22	122K83-2995-495870C4	122K83-2995-495870A2	122K83-2995-495870A5



MORE VOLTAGES

Solenoid Valve	Voltage	ATEX	48 Vdc	24 V / 50 Hz	110 V / 50 Hz
122K83-495905C2	24 VDC	1-21	122K83-495905C4	122K83-495905A2	-
122K83-495905F4	230/50 HZ	1-21	122K83-495905C4	122K83-495905A2	-
122K8306-2995-4818653D	220-230/50 HZ	NON ATEX	122K8306-2995-481865C4	122K8306-2995-481865A2	122K8306-2995-481865A5
122K8306-2995-481865C2	24 VDC	NON ATEX	122K8306-2995-481865C4	122K8306-2995-481865A2	122K8306-2995-481865A5
122K8306-2995-4958703D	220-230/50 HZ	2-22	122K8306-2995-495870C4	122K8306-2995-495870A2	122K8306-2995-495870A5
122K8306-2995-495870C2	24 VDC	2-22	122K8306-2995-495870C4	122K8306-2995-495870A2	122K8306-2995-495870A5
122K8306-495905C2	24 VDC	1-21	122K8306-495905C4	122K8306-495905A2	-
122K8306-495905F4	230/50 HZ	1-21	122K8306-495905C4	122K8306-495905A2	-
122K84-2995-4818653D	220-230/50 HZ	NON ATEX	122K84-2995-481865C4	122K84-2995-481865A2	122K84-2995-481865A5
122K84-2995-481865C2	24 VDC	NON ATEX	122K84-2995-481865C4	122K84-2995-481865A2	122K84-2995-481865A5
122K84-2995-4958703D	220-230/50 HZ	2-22	122K84-2995-495870C4	122K84-2995-495870A2	122K84-2995-495870A5
122K84-2995-495870C2	24 VDC	2-22	122K84-2995-495870C4	122K84-2995-495870A2	122K84-2995-495870A5
122K84-495905C2	24 VDC	1-21	122K84-495905C4	122K84-495905A2	-
122K84-495905F4	230/50 HZ	1-21	122K84-495905C4	122K84-495905A2	-
131B04-496131C2	24 VDC	NON ATEX	131B04-496131C4	-	-
131B04-496131P9	230/50-60 HZ	NON ATEX	131B04-496131C4	-	-
131B04-496637C2	24 VDC	2-22	131B04-496637C4	-	-
131B04-496637P9	230/50-60 HZ	2-22	131B04-496637C4	-	-
131B14-496131C2	24 VDC	NON ATEX	131B14-496131C4	-	-
131B14-496131P9	230/50-60 HZ	NON ATEX	131B14-496131C4	-	-
131B14-496637C2	24 VDC	2-22	131B14-496637C4	-	-
131B14-496637P9	230/50-60 HZ	2-22	131B14-496637C4	-	-
131K1650-2995-4818653D	220-230/50 HZ	NON ATEX	131K1650-2995-481865C4	131K1650-2995-481865A2	131K1650-2995-481865A5
131K1650-2995-481865C2	24 VDC	NON ATEX	131K1650-2995-481865C4	131K1650-2995-481865A2	131K1650-2995-481865A5
131K1650-2995-4958703D	220-230/50 HZ	2-22	131K1650-2995-495870C4	131K1650-2995-495870A2	131K1650-2995-495870A5
131K1650-2995-495870C2	24 VDC	2-22	131K1650-2995-495870C4	131K1650-2995-495870A2	131K1650-2995-495870A5
131K1650-495905C2	24 VDC	1-21	131K1650-495905C4	131K1650-495905A2	-
131K1650-495905F4	230/50 HZ	1-21	131K1650-495905C4	131K1650-495905A2	-
131M14-4826063D	220-230/50 HZ	1-21	131M14-482606C4	131M14-482606A2	-
131M14-482606C2	24 VDC	1-21	131M14-482606C4	131M14-482606A2	-
131M14-8993-4889803D	220-230/50 HZ	NON ATEX	131M14-8993-488980C4	131M14-8993-488980A2	-
131M14-8993-488980C2	24 VDC	NON ATEX	131M14-8993-488980C4	131M14-8993-488980A2	-
131M14-8993-4958653D	220-230/50 HZ	2-22	131M14-8993-495865C4	131M14-8993-495865A2	-
131M14-8993-495865C2	24 VDC	2-22	131M14-8993-495865C4	131M14-8993-495865A2	-
131M15-4826063D	220-230/50 HZ	1-21	131M15-482606C4	131M15-482606A2	-
131M15-482606C2	24 VDC	1-21	131M15-482606C4	131M15-482606A2	-
131M15-8993-4889803D	220-230/50 HZ	NON ATEX	131M15-8993-488980C4	131M15-8993-488980A2	-
131M15-8993-488980C2	24 VDC	NON ATEX	131M15-8993-488980C4	131M15-8993-488980A2	-
131M15-8993-4958653D	220-230/50 HZ	2-22	131M15-8993-495865C4	131M15-8993-495865A2	-
131M15-8993-495865C2	24 VDC	2-22	131M15-8993-495865C4	131M15-8993-495865A2	-
131T21-2995-4818653D	220-230/50 HZ	NON ATEX	131T21-2995-481865C4	131T21-2995-481865A2	131T21-2995-481865A5
131T21-2995-481865C2	24 VDC	NON ATEX	131T21-2995-481865C4	131T21-2995-481865A2	131T21-2995-481865A5
131T21-2995-4958703D	220-230/50 HZ	2-22	131T21-2995-495870C4	131T21-2995-495870A2	131T21-2995-495870A5
131T21-2995-495870C2	24 VDC	2-22	131T21-2995-495870C4	131T21-2995-495870A2	131T21-2995-495870A5
131T21-495905C2	24 VDC	1-21	131T21-495905C4	131T21-495905A2	-
131T21-495905F4	230/50 HZ	1-21	131T21-495905C4	131T21-495905A2	-
131T23-2995-4818653D	220-230/50 HZ	NON ATEX	131T23-2995-481865C4	131T23-2995-481865A2	131T23-2995-481865A5
131T23-2995-481865C2	24 VDC	NON ATEX	131T23-2995-481865C4	131T23-2995-481865A2	131T23-2995-481865A5
131T23-2995-4958703D	220-230/50 HZ	2-22	131T23-2995-495870C4	131T23-2995-495870A2	131T23-2995-495870A5
131T23-2995-495870C2	24 VDC	2-22	131T23-2995-495870C4	131T23-2995-495870A2	131T23-2995-495870A5
131T23-495905C2	24 VDC	1-21	131T23-495905C4	131T23-495905A2	-
131T23-495905F4	230/50 HZ	1-21	131T23-495905C4	131T23-495905A2	-
131T2301-2995-4818653D	220-230/50 HZ	NON ATEX	131T2301-2995-481865C4	131T2301-2995-481865A2	131T2301-2995-481865A5

MORE PRODUCTS



MORE VOLTAGES

Solenoid Valve	Voltage	ATEX	48 Vdc	24 V / 50 Hz	110 V / 50 Hz
131T2301-2995-481865C2	24 VDC	NON ATEX	131T2301-2995-481865C4	131T2301-2995-481865A2	131T2301-2995-481865A5
131T2301-2995-4958703D	220-230/50 HZ	2-22	131T2301-2995-495870C4	131T2301-2995-495870A2	131T2301-2995-495870A5
131T2301-2995-495870C2	24 VDC	2-22	131T2301-2995-495870C4	131T2301-2995-495870A2	131T2301-2995-495870A5
131T2301-495905C2	24 VDC	1-21	131T2301-495905C4	131T2301-495905A2	-
131T2301-495905F4	230/50 HZ	1-21	131T2301-495905C4	131T2301-495905A2	-
131V5306-2995-4818653D	220-230/50 HZ	NON ATEX	131V5306-2995-481865C4	131V5306-2995-481865A2	131V5306-2995-481865A5
131V5306-2995-481865C2	24 VDC	NON ATEX	131V5306-2995-481865C4	131V5306-2995-481865A2	131V5306-2995-481865A5
131V5306-2995-4958703D	220-230/50 HZ	2-22	131V5306-2995-495870C4	131V5306-2995-495870A2	131V5306-2995-495870A5
131V5306-2995-495870C2	24 VDC	2-22	131V5306-2995-495870C4	131V5306-2995-495870A2	131V5306-2995-495870A5
131V5306-495905C2	24 VDC	1-21	131V5306-495905C4	131V5306-495905A2	-
131V5306-495905F4	230/50 HZ	1-21	131V5306-495905C4	131V5306-495905A2	-
132K03-2995-4818653D	220-230/50 HZ	NON ATEX	132K03-2995-481865C4	132K03-2995-481865A2	132K03-2995-481865A5
132K03-2995-481865C2	24 VDC	NON ATEX	132K03-2995-481865C4	132K03-2995-481865A2	132K03-2995-481865A5
132K03-2995-4958703D	220-230/50 HZ	2-22	132K03-2995-495870C4	132K03-2995-495870A2	132K03-2995-495870A5
132K03-2995-495870C2	24 VDC	2-22	132K03-2995-495870C4	132K03-2995-495870A2	132K03-2995-495870A5
132K03-495905C2	24 VDC	1-21	132K03-495905C4	132K03-495905A2	-
132K03-495905F4	230/50 HZ	1-21	132K03-495905C4	132K03-495905A2	-
132K06-2995-4818653D	220-230/50 HZ	NON ATEX	132K06-2995-481865C4	132K06-2995-481865A2	132K06-2995-481865A5
132K06-2995-481865C2	24 VDC	NON ATEX	132K06-2995-481865C4	132K06-2995-481865A2	132K06-2995-481865A5
132K06-2995-4958703D	220-230/50 HZ	2-22	132K06-2995-495870C4	132K06-2995-495870A2	132K06-2995-495870A5
132K06-2995-495870C2	24 VDC	2-22	132K06-2995-495870C4	132K06-2995-495870A2	132K06-2995-495870A5
132K06-495905C2	24 VDC	1-21	132K06-495905C4	132K06-495905A2	-
132K06-495905F4	230/50 HZ	1-21	132K06-495905C4	132K06-495905A2	-
133T23-2995-4818653D	220-230/50 HZ	NON ATEX	133T23-2995-481865C4	133T23-2995-481865A2	133T23-2995-481865A5
133T23-2995-481865C2	24 VDC	NON ATEX	133T23-2995-481865C4	133T23-2995-481865A2	133T23-2995-481865A5
133T23-2995-4958703D	220-230/50 HZ	2-22	133T23-2995-495870C4	133T23-2995-495870A2	133T23-2995-495870A5
133T23-2995-495870C2	24 VDC	2-22	133T23-2995-495870C4	133T23-2995-495870A2	133T23-2995-495870A5
133T23-495905C2	24 VDC	1-21	133T23-495905C4	133T23-495905A2	-
133T23-495905F4	230/50 HZ	1-21	133T23-495905C4	133T23-495905A2	-
133T2301-2995-4818653D	220-230/50 HZ	NON ATEX	133T2301-2995-481865C4	133T2301-2995-481865A2	133T2301-2995-481865A5
133T2301-2995-481865C2	24 VDC	NON ATEX	133T2301-2995-481865C4	133T2301-2995-481865A2	133T2301-2995-481865A5
133T2301-2995-4958703D	220-230/50 HZ	2-22	133T2301-2995-495870C4	133T2301-2995-495870A2	133T2301-2995-495870A5
133T2301-2995-495870C2	24 VDC	2-22	133T2301-2995-495870C4	133T2301-2995-495870A2	133T2301-2995-495870A5
133T2301-495905C2	24 VDC	1-21	133T2301-495905C4	133T2301-495905A2	-
133T2301-495905F4	230/50 HZ	1-21	133T2301-495905C4	133T2301-495905A2	-
133V5406-2995-4818653D	220-230/50 HZ	NON ATEX	133V5406-2995-481865C4	133V5406-2995-481865A2	133V5406-2995-481865A5
133V5406-2995-481865C2	24 VDC	NON ATEX	133V5406-2995-481865C4	133V5406-2995-481865A2	133V5406-2995-481865A5
133V5406-2995-4958703D	220-230/50 HZ	2-22	133V5406-2995-495870C4	133V5406-2995-495870A2	133V5406-2995-495870A5
133V5406-2995-495870C2	24 VDC	2-22	133V5406-2995-495870C4	133V5406-2995-495870A2	133V5406-2995-495870A5
133V5406-495905C2	24 VDC	1-21	133V5406-495905C4	133V5406-495905A2	-
133V5406-495905F4	230/50 HZ	1-21	133V5406-495905C4	133V5406-495905A2	-
221G13-2995-4818653D	220-230/50 HZ	NON ATEX	221G13-2995-481865C4	221G13-2995-481865A2	221G13-2995-481865A5
221G13-2995-492425C2	24 VDC	NON ATEX	-	221G13-2995-492425A2	-
221G13-2995-4958703D	220-230/50 HZ	2-22	221G13-2995-495870C4	221G13-2995-495870A2	221G13-2995-495870A5
221G13-495905F4	230/50 HZ	1-21	221G13-495905C4	221G13-495905A2	-
221G1303-2995-4818653D	220-230/50 HZ	NON ATEX	221G1303-2995-481865C4	221G1303-2995-481865A2	221G1303-2995-481865A5
221G15-2995-4818653D	220-230/50 HZ	NON ATEX	221G15-2995-481865C4	221G15-2995-481865A2	221G15-2995-481865A5
221G15-2995-492425C2	24 VDC	NON ATEX	-	221G15-2995-492425A2	-
221G15-2995-4958703D	220-230/50 HZ	2-22	221G15-2995-495870C4	221G15-2995-495870A2	221G15-2995-495870A5
221G15-495905F4	230/50 HZ	1-21	221G15-495905C4	221G15-495905A2	-
221G1503-2995-4818653D	220-230/50 HZ	NON ATEX	221G1503-2995-481865C4	221G1503-2995-481865A2	221G1503-2995-481865A5
221G1530-2995-481865C2	24 VDC	NON ATEX	221G1530-2995-481865C4	221G1530-2995-481865A2	221G1530-2995-481865A5
221G1530-2995-495870C2	24 VDC	2-22	221G1530-2995-495870C4	221G1530-2995-495870A2	221G1530-2995-495870A5



MORE VOLTAGES

Solenoid Valve	Voltage	ATEX	48 Vdc	24 V / 50 Hz	110 V / 50 Hz
221G1530-495905C2	24 VDC	1-21	221G1530-495905C4	221G1530-495905A2	-
221G16-2995-4818653D	220-230/50 HZ	NON ATEX	221G16-2995-481865C4	221G16-2995-481865A2	221G16-2995-481865A5
221G16-2995-492425C2	24 VDC	NON ATEX	-	221G16-2995-492425A2	-
221G16-2995-4958703D	220-230/50 HZ	2-22	221G16-2995-495870C4	221G16-2995-495870A2	221G16-2995-495870A5
221G16-495905F4	230/50 HZ	1-21	221G16-495905C4	221G16-495905A2	-
221G1603-2995-4818653D	220-230/50 HZ	NON ATEX	221G1603-2995-481865C4	221G1603-2995-481865A2	221G1603-2995-481865A5
221G17-2995-4818653D	220-230/50 HZ	NON ATEX	221G17-2995-481865C4	221G17-2995-481865A2	221G17-2995-481865A5
221G17-2995-492425C2	24 VDC	NON ATEX	-	221G17-2995-492425A2	-
221G17-2995-4958703D	220-230/50 HZ	2-22	221G17-2995-495870C4	221G17-2995-495870A2	221G17-2995-495870A5
221G17-495905F4	230/50 HZ	1-21	221G17-495905C4	221G17-495905A2	-
221G1703-2995-4818653D	220-230/50 HZ	NON ATEX	221G1703-2995-481865C4	221G1703-2995-481865A2	221G1703-2995-481865A5
221G21-2995-4818653D	220-230/50 HZ	NON ATEX	221G21-2995-481865C4	221G21-2995-481865A2	221G21-2995-481865A5
221G21-2995-492425C2	24 VDC	NON ATEX	-	221G21-2995-492425A2	-
221G21-2995-4958703D	220-230/50 HZ	2-22	221G21-2995-495870C4	221G21-2995-495870A2	221G21-2995-495870A5
221G21-495905F4	230/50 HZ	1-21	221G21-495905C4	221G21-495905A2	-
221G2130-2995-481865C2	24 VDC	NON ATEX	221G2130-2995-481865C4	221G2130-2995-481865A2	221G2130-2995-481865A5
221G2130-2995-495870C2	24 VDC	2-22	221G2130-2995-495870C4	221G2130-2995-495870A2	221G2130-2995-495870A5
221G2130-495905C2	24 VDC	1-21	221G2130-495905C4	221G2130-495905A2	-
221G25-2995-4818653D	220-230/50 HZ	NON ATEX	221G25-2995-481865C4	221G25-2995-481865A2	221G25-2995-481865A5
221G25-2995-492425C2	24 VDC	NON ATEX	-	221G25-2995-492425A2	-
221G25-2995-4958703D	220-230/50 HZ	2-22	221G25-2995-495870C4	221G25-2995-495870A2	221G25-2995-495870A5
221G25-495905F4	230/50 HZ	1-21	221G25-495905C4	221G25-495905A2	-
221G2530-2995-481865C2	24 VDC	NON ATEX	221G2530-2995-481865C4	221G2530-2995-481865A2	221G2530-2995-481865A5
221G2530-2995-495870C2	24 VDC	2-22	221G2530-2995-495870C4	221G2530-2995-495870A2	221G2530-2995-495870A5
221G2530-495905C2	24 VDC	1-21	221G2530-495905C4	221G2530-495905A2	-
221G26-2995-4818653D	220-230/50 HZ	NON ATEX	221G26-2995-481865C4	221G26-2995-481865A2	221G26-2995-481865A5
221G26-2995-492425C2	24 VDC	NON ATEX	-	221G26-2995-492425A2	-
221G26-2995-4958703D	220-230/50 HZ	2-22	221G26-2995-495870C4	221G26-2995-495870A2	221G26-2995-495870A5
221G26-495905F4	230/50 HZ	1-21	221G26-495905C4	221G26-495905A2	-
221S10F-2995-4818653D	220-230/50 HZ	NON ATEX	221S10F-2995-481865C4	221S10F-2995-481865A2	221S10F-2995-481865A5
221S15F-2995-4818653D	220-230/50 HZ	NON ATEX	221S15F-2995-481865C4	221S15F-2995-481865A2	221S15F-2995-481865A5
221S20F-2995-4818653D	220-230/50 HZ	NON ATEX	221S20F-2995-481865C4	221S20F-2995-481865A2	221S20F-2995-481865A5
221S25F-2995-4818653D	220-230/50 HZ	NON ATEX	221S25F-2995-481865C4	221S25F-2995-481865A2	221S25F-2995-481865A5
321K3106-4826063D	220-230/50 HZ	1-21	321K3106-482606C4	321K3106-482606A2	-
321K3106-482606C2	24 VDC	1-21	321K3106-482606C4	321K3106-482606A2	-
321K3106-8993-4889803D	220-230/50 HZ	NON ATEX	321K3106-8993-488980C4	321K3106-8993-488980A2	-
321K3106-8993-488980C2	24 VDC	NON ATEX	321K3106-8993-488980C4	321K3106-8993-488980A2	-
321K3106-8993-4958653D	220-230/50 HZ	2-22	321K3106-8993-495865C4	321K3106-8993-495865A2	-
321K3106-8993-495865C2	24 VDC	2-22	321K3106-8993-495865C4	321K3106-8993-495865A2	-
321K3306-4826063D	220-230/50 HZ	1-21	321K3306-482606C4	321K3306-482606A2	-
321K3306-482606C2	24 VDC	1-21	321K3306-482606C4	321K3306-482606A2	-
321K3306-8993-4889803D	220-230/50 HZ	NON ATEX	321K3306-8993-488980C4	321K3306-8993-488980A2	-
321K3306-8993-488980C2	24 VDC	NON ATEX	321K3306-8993-488980C4	321K3306-8993-488980A2	-
321K3306-8993-4958653D	220-230/50 HZ	2-22	321K3306-8993-495865C4	321K3306-8993-495865A2	-
321K3306-8993-495865C2	24 VDC	2-22	321K3306-8993-495865C4	321K3306-8993-495865A2	-
321K35-4826063D	220-230/50 HZ	1-21	321K35-482606C4	321K35-482606A2	-
321K35-482606C2	24 VDC	1-21	321K35-482606C4	321K35-482606A2	-
321K35-8993-4889803D	220-230/50 HZ	NON ATEX	321K35-8993-488980C4	321K35-8993-488980A2	-
321K35-8993-488980C2	24 VDC	NON ATEX	321K35-8993-488980C4	321K35-8993-488980A2	-
321K35-8993-4958653D	220-230/50 HZ	2-22	321K35-8993-495865C4	321K35-8993-495865A2	-
321K35-8993-495865C2	24 VDC	2-22	321K35-8993-495865C4	321K35-8993-495865A2	-
321K3506-4826063D	220-230/50 HZ	1-21	321K3506-482606C4	321K3506-482606A2	-
321K3506-482606C2	24 VDC	1-21	321K3506-482606C4	321K3506-482606A2	-

MORE PRODUCTS



MORE VOLTAGES

Solenoid Valve	Voltage	ATEX	48 Vdc	24 V / 50 Hz	110 V / 50 Hz
321K3506-8993-4889803D	220-230/50 HZ	NON ATEX	321K3506-8993-488980C4	321K3506-8993-488980A2	-
321K3506-8993-488980C2	24 VDC	NON ATEX	321K3506-8993-488980C4	321K3506-8993-488980A2	-
321K3506-8993-4958653D	220-230/50 HZ	2-22	321K3506-8993-495865C4	321K3506-8993-495865A2	-
321K3506-8993-495865C2	24 VDC	2-22	321K3506-8993-495865C4	321K3506-8993-495865A2	-
321K36-4826063D	220-230/50 HZ	1-21	321K36-482606C4	321K36-482606A2	-
321K36-482606C2	24 VDC	1-21	321K36-482606C4	321K36-482606A2	-
321K36-8993-4889803D	220-230/50 HZ	NON ATEX	321K36-8993-488980C4	321K36-8993-488980A2	-
321K36-8993-488980C2	24 VDC	NON ATEX	321K36-8993-488980C4	321K36-8993-488980A2	-
321K36-8993-4958653D	220-230/50 HZ	2-22	321K36-8993-495865C4	321K36-8993-495865A2	-
321K36-8993-495865C2	24 VDC	2-22	321K36-8993-495865C4	321K36-8993-495865A2	-
321K3606-4826063D	220-230/50 HZ	1-21	321K3606-482606C4	321K3606-482606A2	-
321K3606-482606C2	24 VDC	1-21	321K3606-482606C4	321K3606-482606A2	-
321K3606-8993-4889803D	220-230/50 HZ	NON ATEX	321K3606-8993-488980C4	321K3606-8993-488980A2	-
321K3606-8993-488980C2	24 VDC	NON ATEX	321K3606-8993-488980C4	321K3606-8993-488980A2	-
321K3606-8993-4958653D	220-230/50 HZ	2-22	321K3606-8993-495865C4	321K3606-8993-495865A2	-
321K3606-8993-495865C2	24 VDC	2-22	321K3606-8993-495865C4	321K3606-8993-495865A2	-
321K37-4826063D	220-230/50 HZ	1-21	321K37-482606C4	321K37-482606A2	-
321K37-482606C2	24 VDC	1-21	321K37-482606C4	321K37-482606A2	-
321K37-8993-4889803D	220-230/50 HZ	NON ATEX	321K37-8993-488980C4	321K37-8993-488980A2	-
321K37-8993-488980C2	24 VDC	NON ATEX	321K37-8993-488980C4	321K37-8993-488980A2	-
321K37-8993-4958653D	220-230/50 HZ	2-22	321K37-8993-495865C4	321K37-8993-495865A2	-
321K37-8993-495865C2	24 VDC	2-22	321K37-8993-495865C4	321K37-8993-495865A2	-
321K3706-4826063D	220-230/50 HZ	1-21	321K3706-482606C4	321K3706-482606A2	-
321K3706-482606C2	24 VDC	1-21	321K3706-482606C4	321K3706-482606A2	-
321K3706-8993-4889803D	220-230/50 HZ	NON ATEX	321K3706-8993-488980C4	321K3706-8993-488980A2	-
321K3706-8993-488980C2	24 VDC	NON ATEX	321K3706-8993-488980C4	321K3706-8993-488980A2	-
321K3706-8993-4958653D	220-230/50 HZ	2-22	321K3706-8993-495865C4	321K3706-8993-495865A2	-
321K3706-8993-495865C2	24 VDC	2-22	321K3706-8993-495865C4	321K3706-8993-495865A2	-
322G75-2995-4818653D	220-230/50 HZ	NON ATEX	322G75-2995-481865C4	322G75-2995-481865A2	322G75-2995-481865A5
322G75-2995-481865C2	24 VDC	NON ATEX	322G75-2995-481865C4	322G75-2995-481865A2	322G75-2995-481865A5
322G75-2995-4958703D	220-230/50 HZ	2-22	322G75-2995-495870C4	322G75-2995-495870A2	322G75-2995-495870A5
322G75-2995-495870C2	24 VDC	2-22	322G75-2995-495870C4	322G75-2995-495870A2	322G75-2995-495870A5
322G75-495905C2	24 VDC	1-21	322G75-495905C4	322G75-495905A2	-
322G75-495905F4	230/50 HZ	1-21	322G75-495905C4	322G75-495905A2	-
322H75-2995-4818653D	220-230/50 HZ	NON ATEX	322H75-2995-481865C4	322H75-2995-481865A2	322H75-2995-481865A5
322H75-2995-481865C2	24 VDC	NON ATEX	322H75-2995-481865C4	322H75-2995-481865A2	322H75-2995-481865A5
322H75-2995-4958703D	220-230/50 HZ	2-22	322H75-2995-495870C4	322H75-2995-495870A2	322H75-2995-495870A5
322H75-2995-495870C2	24 VDC	2-22	322H75-2995-495870C4	322H75-2995-495870A2	322H75-2995-495870A5
322H75-495905C2	24 VDC	1-21	322H75-495905C4	322H75-495905A2	-
322H75-495905F4	230/50 HZ	1-21	322H75-495905C4	322H75-495905A2	-
322H7506-2995-4818653D	220-230/50 HZ	NON ATEX	322H7506-2995-481865C4	322H7506-2995-481865A2	322H7506-2995-481865A5
322H7506-2995-481865C2	24 VDC	NON ATEX	322H7506-2995-481865C4	322H7506-2995-481865A2	322H7506-2995-481865A5
322H7506-2995-4958703D	220-230/50 HZ	2-22	322H7506-2995-495870C4	322H7506-2995-495870A2	322H7506-2995-495870A5
322H7506-2995-495870C2	24 VDC	2-22	322H7506-2995-495870C4	322H7506-2995-495870A2	322H7506-2995-495870A5
322H7506-495905C2	24 VDC	1-21	322H7506-495905C4	322H7506-495905A2	-
322H7506-495905F4	230/50 HZ	1-21	322H7506-495905C4	322H7506-495905A2	-
322K4106-2995-4818653D	220-230/50 HZ	NON ATEX	322K4106-2995-481865C4	322K4106-2995-481865A2	322K4106-2995-481865A5
322K4106-2995-481865C2	24 VDC	NON ATEX	322K4106-2995-481865C4	322K4106-2995-481865A2	322K4106-2995-481865A5
322K4106-2995-4958703D	220-230/50 HZ	2-22	322K4106-2995-495870C4	322K4106-2995-495870A2	322K4106-2995-495870A5
322K4106-2995-495870C2	24 VDC	2-22	322K4106-2995-495870C4	322K4106-2995-495870A2	322K4106-2995-495870A5
322K4106-495905C2	24 VDC	1-21	322K4106-495905C4	322K4106-495905A2	-
322K4106-495905F4	230/50 HZ	1-21	322K4106-495905C4	322K4106-495905A2	-
322K4506-2995-4818653D	220-230/50 HZ	NON ATEX	322K4506-2995-481865C4	322K4506-2995-481865A2	322K4506-2995-481865A5



MORE VOLTAGES

Solenoid Valve	Voltage	ATEX	48 Vdc	24 V / 50 Hz	110 V / 50 Hz
322K4506-2995-481865C2	24 VDC	NON ATEX	322K4506-2995-481865C4	322K4506-2995-481865A2	322K4506-2995-481865A5
322K4506-2995-4958703D	220-230/50 HZ	2-22	322K4506-2995-495870C4	322K4506-2995-495870A2	322K4506-2995-495870A5
322K4506-2995-495870C2	24 VDC	2-22	322K4506-2995-495870C4	322K4506-2995-495870A2	322K4506-2995-495870A5
322K4506-495905C2	24 VDC	1-21	322K4506-495905C4	322K4506-495905A2	-
322K4506-495905F4	230/50 HZ	1-21	322K4506-495905C4	322K4506-495905A2	-
322K4606-2995-4818653D	220-230/50 HZ	NON ATEX	322K4606-2995-481865C4	322K4606-2995-481865A2	322K4606-2995-481865A5
322K4606-2995-481865C2	24 VDC	NON ATEX	322K4606-2995-481865C4	322K4606-2995-481865A2	322K4606-2995-481865A5
322K4606-2995-4958703D	220-230/50 HZ	2-22	322K4606-2995-495870C4	322K4606-2995-495870A2	322K4606-2995-495870A5
322K4606-2995-495870C2	24 VDC	2-22	322K4606-2995-495870C4	322K4606-2995-495870A2	322K4606-2995-495870A5
322K4606-495905C2	24 VDC	1-21	322K4606-495905C4	322K4606-495905A2	-
322K4606-495905F4	230/50 HZ	1-21	322K4606-495905C4	322K4606-495905A2	-
331N04-496131C2	24 VDC	NON ATEX	331N04-496131C4	-	-
331N04-496131P9	230/50-60 HZ	NON ATEX	331N04-496131C4	-	-
331N04-496637C2	24 VDC	2-22	331N04-496637C4	-	-
331N04-496637P9	230/50-60 HZ	2-22	331N04-496637C4	-	-
331N34-2995-4818653D	220-230/50 HZ	NON ATEX	331N34-2995-481865C4	331N34-2995-481865A2	331N34-2995-481865A5
331N34-2995-481865C2	24 VDC	NON ATEX	331N34-2995-481865C4	331N34-2995-481865A2	331N34-2995-481865A5
331N34-2995-4958703D	220-230/50 HZ	2-22	331N34-2995-495870C4	331N34-2995-495870A2	331N34-2995-495870A5
331N34-2995-495870C2	24 VDC	2-22	331N34-2995-495870C4	331N34-2995-495870A2	331N34-2995-495870A5
331N34-495905C2	24 VDC	1-21	331N34-495905C4	331N34-495905A2	-
331N34-495905F4	230/50 HZ	1-21	331N34-495905C4	331N34-495905A2	-
341N04-496131C2	24 VDC	NON ATEX	341N04-496131C4	-	-
341N04-496131P9	230/50-60 HZ	NON ATEX	341N04-496131C4	-	-
341N04-496637C2	24 VDC	2-22	341N04-496637C4	-	-
341N04-496637P9	230/50-60 HZ	2-22	341N04-496637C4	-	-
341N05-496131C2	24 VDC	NON ATEX	341N05-496131C4	-	-
341N05-496131P9	230/50-60 HZ	NON ATEX	341N05-496131C4	-	-
341N05-496637C2	24 VDC	2-22	341N05-496637C4	-	-
341N05-496637P9	230/50-60 HZ	2-22	341N05-496637C4	-	-
341N34-2995-4818653D	220-230/50 HZ	NON ATEX	341N34-2995-481865C4	341N34-2995-481865A2	341N34-2995-481865A5
341N34-2995-481865C2	24 VDC	NON ATEX	341N34-2995-481865C4	341N34-2995-481865A2	341N34-2995-481865A5
341N34-2995-4958703D	220-230/50 HZ	2-22	341N34-2995-495870C4	341N34-2995-495870A2	341N34-2995-495870A5
341N34-2995-495870C2	24 VDC	2-22	341N34-2995-495870C4	341N34-2995-495870A2	341N34-2995-495870A5
341N34-495905C2	24 VDC	1-21	341N34-495905C4	341N34-495905A2	-
341N34-495905F4	230/50 HZ	1-21	341N34-495905C4	341N34-495905A2	-
341N35-2995-4818653D	220-230/50 HZ	NON ATEX	341N35-2995-481865C4	341N35-2995-481865A2	341N35-2995-481865A5
341N35-2995-481865C2	24 VDC	NON ATEX	341N35-2995-481865C4	341N35-2995-481865A2	341N35-2995-481865A5
341N35-2995-4958703D	220-230/50 HZ	2-22	341N35-2995-495870C4	341N35-2995-495870A2	341N35-2995-495870A5
341N35-2995-495870C2	24 VDC	2-22	341N35-2995-495870C4	341N35-2995-495870A2	341N35-2995-495870A5
341N35-495905C2	24 VDC	1-21	341N35-495905C4	341N35-495905A2	-
341N35-495905F4	230/50 HZ	1-21	341N35-495905C4	341N35-495905A2	-
341P03-496131C2	24 VDC	NON ATEX	341P03-496131C4	-	-
341P03-496131P9	230/50-60 HZ	NON ATEX	341P03-496131C4	-	-
341P03-496637C2	24 VDC	2-22	341P03-496637C4	-	-
341P03-496637P9	230/50-60 HZ	2-22	341P03-496637C4	-	-
341P04-496131C2	24 VDC	NON ATEX	341P04-496131C4	-	-
341P04-496131P9	230/50-60 HZ	NON ATEX	341P04-496131C4	-	-
341P04-496637C2	24 VDC	2-22	341P04-496637C4	-	-
341P04-496637P9	230/50-60 HZ	2-22	341P04-496637C4	-	-
347N03-496131C2	24 VDC	NON ATEX	347N03-496131C4	-	-
347N03-496131P9	230/50-60 HZ	NON ATEX	347N03-496131C4	-	-
347N03-496637C2	24 VDC	2-22	347N03-496637C4	-	-
347N03-496637P9	230/50-60 HZ	2-22	347N03-496637C4	-	-

MORE PRODUCTS



MORE VOLTAGES

Solenoid Valve	Voltage	ATEX	48 Vdc	24 V / 50 Hz	110 V / 50 Hz
347N04-496131C2	24 VDC	NON ATEX	347N04-496131C4	-	-
347N04-496131P9	230/50-60 HZ	NON ATEX	347N04-496131C4	-	-
347N04-496637C2	24 VDC	2-22	347N04-496637C4	-	-
347N04-496637P9	230/50-60 HZ	2-22	347N04-496637C4	-	-
347N33-2995-4818653D	220-230/50 HZ	NON ATEX	347N33-2995-481865C4	347N33-2995-481865A2	347N33-2995-481865A5
347N33-2995-481865C2	24 VDC	NON ATEX	347N33-2995-481865C4	347N33-2995-481865A2	347N33-2995-481865A5
347N33-2995-4958703D	220-230/50 HZ	2-22	347N33-2995-495870C4	347N33-2995-495870A2	347N33-2995-495870A5
347N33-2995-495870C2	24 VDC	2-22	347N33-2995-495870C4	347N33-2995-495870A2	347N33-2995-495870A5
347N33-495905C2	24 VDC	1-21	347N33-495905C4	347N33-495905A2	-
347N33-495905F4	230/50 HZ	1-21	347N33-495905C4	347N33-495905A2	-
347N34-2995-4818653D	220-230/50 HZ	NON ATEX	347N34-2995-481865C4	347N34-2995-481865A2	347N34-2995-481865A5
347N34-2995-481865C2	24 VDC	NON ATEX	347N34-2995-481865C4	347N34-2995-481865A2	347N34-2995-481865A5
347N34-2995-4958703D	220-230/50 HZ	2-22	347N34-2995-495870C4	347N34-2995-495870A2	347N34-2995-495870A5
347N34-2995-495870C2	24 VDC	2-22	347N34-2995-495870C4	347N34-2995-495870A2	347N34-2995-495870A5
347N34-495905C2	24 VDC	1-21	347N34-495905C4	347N34-495905A2	-
347N34-495905F4	230/50 HZ	1-21	347N34-495905C4	347N34-495905A2	-
347P03-496131C2	24 VDC	NON ATEX	347P03-496131C4	-	-
347P03-496131P9	230/50-60 HZ	NON ATEX	347P03-496131C4	-	-
347P03-496637C2	24 VDC	2-22	347P03-496637C4	-	-
347P03-496637P9	230/50-60 HZ	2-22	347P03-496637C4	-	-
347P04-496131C2	24 VDC	NON ATEX	347P04-496131C4	-	-
347P04-496131P9	230/50-60 HZ	NON ATEX	347P04-496131C4	-	-
347P04-496637C2	24 VDC	2-22	347P04-496637C4	-	-
347P04-496637P9	230/50-60 HZ	2-22	347P04-496637C4	-	-
E121K03-2995-4818653D	220-230/50 HZ	NON ATEX	E121K03-2995-481865C4	E121K03-2995-481865A2	E121K03-2995-481865A5
E121K03-2995-481865C2	24 VDC	NON ATEX	E121K03-2995-481865C4	E121K03-2995-481865A2	E121K03-2995-481865A5
E121K03-2995-4958703D	220-230/50 HZ	2-22	E121K03-2995-495870C4	E121K03-2995-495870A2	E121K03-2995-495870A5
E121K03-2995-495870C2	24 VDC	2-22	E121K03-2995-495870C4	E121K03-2995-495870A2	E121K03-2995-495870A5
E121K03-495905C2	24 VDC	1-21	E121K03-495905C4	E121K03-495905A2	-
E121K03-495905F4	230/50 HZ	1-21	E121K03-495905C4	E121K03-495905A2	-
E121K0302-2995-4818653D	220-230/50 HZ	NON ATEX	E121K0302-2995-481865C4	E121K0302-2995-481865A2	E121K0302-2995-481865A5
E121K0302-2995-481865C2	24 VDC	NON ATEX	E121K0302-2995-481865C4	E121K0302-2995-481865A2	E121K0302-2995-481865A5
E121K0302-2995-4958703D	220-230/50 HZ	2-22	E121K0302-2995-495870C4	E121K0302-2995-495870A2	E121K0302-2995-495870A5
E121K0302-2995-495870C2	24 VDC	2-22	E121K0302-2995-495870C4	E121K0302-2995-495870A2	E121K0302-2995-495870A5
E121K0302-495905C2	24 VDC	1-21	E121K0302-495905C4	E121K0302-495905A2	-
E121K0302-495905F4	230/50 HZ	1-21	E121K0302-495905C4	E121K0302-495905A2	-
E121K0352-2995-4818653D	220-230/50 HZ	NON ATEX	E121K0352-2995-481865C4	E121K0352-2995-481865A2	E121K0352-2995-481865A5
E121K0352-2995-481865C2	24 VDC	NON ATEX	E121K0352-2995-481865C4	E121K0352-2995-481865A2	E121K0352-2995-481865A5
E121K0352-2995-4958703D	220-230/50 HZ	2-22	E121K0352-2995-495870C4	E121K0352-2995-495870A2	E121K0352-2995-495870A5
E121K0352-2995-495870C2	24 VDC	2-22	E121K0352-2995-495870C4	E121K0352-2995-495870A2	E121K0352-2995-495870A5
E121K0352-495905C2	24 VDC	1-21	E121K0352-495905C4	E121K0352-495905A2	-
E121K0352-495905F4	230/50 HZ	1-21	E121K0352-495905C4	E121K0352-495905A2	-
E121K04-2995-4818653D	220-230/50 HZ	NON ATEX	E121K04-2995-481865C4	E121K04-2995-481865A2	E121K04-2995-481865A5
E121K04-2995-481865C2	24 VDC	NON ATEX	E121K04-2995-481865C4	E121K04-2995-481865A2	E121K04-2995-481865A5
E121K04-2995-4958703D	220-230/50 HZ	2-22	E121K04-2995-495870C4	E121K04-2995-495870A2	E121K04-2995-495870A5
E121K04-2995-495870C2	24 VDC	2-22	E121K04-2995-495870C4	E121K04-2995-495870A2	E121K04-2995-495870A5
E121K04-495905C2	24 VDC	1-21	E121K04-495905C4	E121K04-495905A2	-
E121K04-495905F4	230/50 HZ	1-21	E121K04-495905C4	E121K04-495905A2	-
E121K45-2995-4818653D	220-230/50 HZ	NON ATEX	E121K45-2995-481865C4	E121K45-2995-481865A2	E121K45-2995-481865A5
E121K45-2995-481865C2	24 VDC	NON ATEX	E121K45-2995-481865C4	E121K45-2995-481865A2	E121K45-2995-481865A5
E121K45-2995-4958703D	220-230/50 HZ	2-22	E121K45-2995-495870C4	E121K45-2995-495870A2	E121K45-2995-495870A5
E121K45-2995-495870C2	24 VDC	2-22	E121K45-2995-495870C4	E121K45-2995-495870A2	E121K45-2995-495870A5
E121K45-495905C2	24 VDC	1-21	E121K45-495905C4	E121K45-495905A2	-



MORE VOLTAGES

Solenoid Valve	Voltage	ATEX	48 Vdc	24 V / 50 Hz	110 V / 50 Hz
E121K45-495905F4	230/50 HZ	1-21	E121K45-495905C4	E121K45-495905A2	-
E121K46-2995-4818653D	220-230/50 HZ	NON ATEX	E121K46-2995-481865C4	E121K46-2995-481865A2	E121K46-2995-481865A5
E121K46-2995-481865C2	24 VDC	NON ATEX	E121K46-2995-481865C4	E121K46-2995-481865A2	E121K46-2995-481865A5
E121K46-2995-492425C2	24 VDC	NON ATEX	-	E121K46-2995-492425A2	-
E121K46-2995-492425F4	230/50 HZ	NON ATEX	-	E121K46-2995-492425A2	-
E121K46-2995-4958703D	220-230/50 HZ	2-22	E121K46-2995-495870C4	E121K46-2995-495870A2	E121K46-2995-495870A5
E121K46-2995-495870C2	24 VDC	2-22	E121K46-2995-495870C4	E121K46-2995-495870A2	E121K46-2995-495870A5
E121K46-495905C2	24 VDC	1-21	E121K46-495905C4	E121K46-495905A2	-
E121K46-495905F4	230/50 HZ	1-21	E121K46-495905C4	E121K46-495905A2	-
E121K63-2995-4818653D	220-230/50 HZ	NON ATEX	E121K63-2995-481865C4	E121K63-2995-481865A2	E121K63-2995-481865A5
E121K63-2995-481865C2	24 VDC	NON ATEX	E121K63-2995-481865C4	E121K63-2995-481865A2	E121K63-2995-481865A5
E121K63-2995-4958703D	220-230/50 HZ	2-22	E121K63-2995-495870C4	E121K63-2995-495870A2	E121K63-2995-495870A5
E121K63-2995-495870C2	24 VDC	2-22	E121K63-2995-495870C4	E121K63-2995-495870A2	E121K63-2995-495870A5
E121K63-495905C2	24 VDC	1-21	E121K63-495905C4	E121K63-495905A2	-
E121K63-495905F4	230/50 HZ	1-21	E121K63-495905C4	E121K63-495905A2	-
E121K64-2995-4818653D	220-230/50 HZ	NON ATEX	E121K64-2995-481865C4	E121K64-2995-481865A2	E121K64-2995-481865A5
E121K64-2995-481865C2	24 VDC	NON ATEX	E121K64-2995-481865C4	E121K64-2995-481865A2	E121K64-2995-481865A5
E121K64-2995-4958703D	220-230/50 HZ	2-22	E121K64-2995-495870C4	E121K64-2995-495870A2	E121K64-2995-495870A5
E121K64-2995-495870C2	24 VDC	2-22	E121K64-2995-495870C4	E121K64-2995-495870A2	E121K64-2995-495870A5
E121K64-495905C2	24 VDC	1-21	E121K64-495905C4	E121K64-495905A2	-
E121K64-495905F4	230/50 HZ	1-21	E121K64-495905C4	E121K64-495905A2	-
E121K65-2995-4818653D	220-230/50 HZ	NON ATEX	E121K65-2995-481865C4	E121K65-2995-481865A2	E121K65-2995-481865A5
E121K65-2995-481865C2	24 VDC	NON ATEX	E121K65-2995-481865C4	E121K65-2995-481865A2	E121K65-2995-481865A5
E121K65-2995-4958703D	220-230/50 HZ	2-22	E121K65-2995-495870C4	E121K65-2995-495870A2	E121K65-2995-495870A5
E121K65-2995-495870C2	24 VDC	2-22	E121K65-2995-495870C4	E121K65-2995-495870A2	E121K65-2995-495870A5
E121K65-495905C2	24 VDC	1-21	E121K65-495905C4	E121K65-495905A2	-
E121K65-495905F4	230/50 HZ	1-21	E121K65-495905C4	E121K65-495905A2	-
E131K03-2995-4818653D	220-230/50 HZ	NON ATEX	E131K03-2995-481865C4	E131K03-2995-481865A2	E131K03-2995-481865A5
E131K03-2995-481865C2	24 VDC	NON ATEX	E131K03-2995-481865C4	E131K03-2995-481865A2	E131K03-2995-481865A5
E131K03-2995-4958703D	220-230/50 HZ	2-22	E131K03-2995-495870C4	E131K03-2995-495870A2	E131K03-2995-495870A5
E131K03-2995-495870C2	24 VDC	2-22	E131K03-2995-495870C4	E131K03-2995-495870A2	E131K03-2995-495870A5
E131K03-495905C2	24 VDC	1-21	E131K03-495905C4	E131K03-495905A2	-
E131K03-495905F4	230/50 HZ	1-21	E131K03-495905C4	E131K03-495905A2	-
E131K0350-2995-4818653D	220-230/50 HZ	NON ATEX	E131K0350-2995-481865C4	E131K0350-2995-481865A2	E131K0350-2995-481865A5
E131K0350-2995-481865C2	24 VDC	NON ATEX	E131K0350-2995-481865C4	E131K0350-2995-481865A2	E131K0350-2995-481865A5
E131K0350-2995-4958703D	220-230/50 HZ	2-22	E131K0350-2995-495870C4	E131K0350-2995-495870A2	E131K0350-2995-495870A5
E131K0350-2995-495870C2	24 VDC	2-22	E131K0350-2995-495870C4	E131K0350-2995-495870A2	E131K0350-2995-495870A5
E131K0350-495905C2	24 VDC	1-21	E131K0350-495905C4	E131K0350-495905A2	-
E131K0350-495905F4	230/50 HZ	1-21	E131K0350-495905C4	E131K0350-495905A2	-
E131K04-2995-4818653D	220-230/50 HZ	NON ATEX	E131K04-2995-481865C4	E131K04-2995-481865A2	E131K04-2995-481865A5
E131K04-2995-481865C2	24 VDC	NON ATEX	E131K04-2995-481865C4	E131K04-2995-481865A2	E131K04-2995-481865A5
E131K04-2995-4958703D	220-230/50 HZ	2-22	E131K04-2995-495870C4	E131K04-2995-495870A2	E131K04-2995-495870A5
E131K04-2995-495870C2	24 VDC	2-22	E131K04-2995-495870C4	E131K04-2995-495870A2	E131K04-2995-495870A5
E131K04-495905C2	24 VDC	1-21	E131K04-495905C4	E131K04-495905A2	-
E131K04-495905F4	230/50 HZ	1-21	E131K04-495905C4	E131K04-495905A2	-
E131K0450-2995-4818653D	220-230/50 HZ	NON ATEX	E131K0450-2995-481865C4	E131K0450-2995-481865A2	E131K0450-2995-481865A5
E131K0450-2995-481865C2	24 VDC	NON ATEX	E131K0450-2995-481865C4	E131K0450-2995-481865A2	E131K0450-2995-481865A5
E131K0450-2995-4958703D	220-230/50 HZ	2-22	E131K0450-2995-495870C4	E131K0450-2995-495870A2	E131K0450-2995-495870A5
E131K0450-2995-495870C2	24 VDC	2-22	E131K0450-2995-495870C4	E131K0450-2995-495870A2	E131K0450-2995-495870A5
E131K0450-495905C2	24 VDC	1-21	E131K0450-495905C4	E131K0450-495905A2	-
E131K0450-495905F4	230/50 HZ	1-21	E131K0450-495905C4	E131K0450-495905A2	-
E131K06-2995-4818653D	220-230/50 HZ	NON ATEX	E131K06-2995-481865C4	E131K06-2995-481865A2	E131K06-2995-481865A5
E131K06-2995-481865C2	24 VDC	NON ATEX	E131K06-2995-481865C4	E131K06-2995-481865A2	E131K06-2995-481865A5

MORE PRODUCTS



MORE VOLTAGES

Solenoid Valve	Voltage	ATEX	48 Vdc	24 V / 50 Hz	110 V / 50 Hz
E131K06-2995-4958703D	220-230/50 HZ	2-22	E131K06-2995-495870C4	E131K06-2995-495870A2	E131K06-2995-495870A5
E131K06-2995-495870C2	24 VDC	2-22	E131K06-2995-495870C4	E131K06-2995-495870A2	E131K06-2995-495870A5
E131K06-495905C2	24 VDC	1-21	E131K06-495905C4	E131K06-495905A2	-
E131K06-495905F4	230/50 HZ	1-21	E131K06-495905C4	E131K06-495905A2	-
E131K0650-2995-4818653D	220-230/50 HZ	NON ATEX	E131K0650-2995-481865C4	E131K0650-2995-481865A2	E131K0650-2995-481865A5
E131K0650-2995-481865C2	24 VDC	NON ATEX	E131K0650-2995-481865C4	E131K0650-2995-481865A2	E131K0650-2995-481865A5
E131K0650-2995-4958703D	220-230/50 HZ	2-22	E131K0650-2995-495870C4	E131K0650-2995-495870A2	E131K0650-2995-495870A5
E131K0650-2995-495870C2	24 VDC	2-22	E131K0650-2995-495870C4	E131K0650-2995-495870A2	E131K0650-2995-495870A5
E131K0650-495905C2	24 VDC	1-21	E131K0650-495905C4	E131K0650-495905A2	-
E131K0650-495905F4	230/50 HZ	1-21	E131K0650-495905C4	E131K0650-495905A2	-
E131K13-2995-4818653D	220-230/50 HZ	NON ATEX	E131K13-2995-481865C4	E131K13-2995-481865A2	E131K13-2995-481865A5
E131K13-2995-481865C2	24 VDC	NON ATEX	E131K13-2995-481865C4	E131K13-2995-481865A2	E131K13-2995-481865A5
E131K13-2995-4958703D	220-230/50 HZ	2-22	E131K13-2995-495870C4	E131K13-2995-495870A2	E131K13-2995-495870A5
E131K13-2995-495870C2	24 VDC	2-22	E131K13-2995-495870C4	E131K13-2995-495870A2	E131K13-2995-495870A5
E131K13-495905C2	24 VDC	1-21	E131K13-495905C4	E131K13-495905A2	-
E131K13-495905F4	230/50 HZ	1-21	E131K13-495905C4	E131K13-495905A2	-
E133K05-2995-4818653D	220-230/50 HZ	NON ATEX	E133K05-2995-481865C4	E133K05-2995-481865A2	E133K05-2995-481865A5
E133K05-2995-481865C2	24 VDC	NON ATEX	E133K05-2995-481865C4	E133K05-2995-481865A2	E133K05-2995-481865A5
E133K05-2995-4958703D	220-230/50 HZ	2-22	E133K05-2995-495870C4	E133K05-2995-495870A2	E133K05-2995-495870A5
E133K05-2995-495870C2	24 VDC	2-22	E133K05-2995-495870C4	E133K05-2995-495870A2	E133K05-2995-495870A5
E133K05-495905C2	24 VDC	1-21	E133K05-495905C4	E133K05-495905A2	-
E133K05-495905F4	230/50 HZ	1-21	E133K05-495905C4	E133K05-495905A2	-
E133K06-2995-4818653D	220-230/50 HZ	NON ATEX	E133K06-2995-481865C4	E133K06-2995-481865A2	E133K06-2995-481865A5
E133K06-2995-481865C2	24 VDC	NON ATEX	E133K06-2995-481865C4	E133K06-2995-481865A2	E133K06-2995-481865A5
E133K06-2995-4958703D	220-230/50 HZ	2-22	E133K06-2995-495870C4	E133K06-2995-495870A2	E133K06-2995-495870A5
E133K06-2995-495870C2	24 VDC	2-22	E133K06-2995-495870C4	E133K06-2995-495870A2	E133K06-2995-495870A5
E133K06-495905C2	24 VDC	1-21	E133K06-495905C4	E133K06-495905A2	-
E133K06-495905F4	230/50 HZ	1-21	E133K06-495905C4	E133K06-495905A2	-
E321H11-2995-4818653D	220-230/50 HZ	NON ATEX	E321H11-2995-481865C4	E321H11-2995-481865A2	E321H11-2995-481865A5
E321H11-2995-481865C2	24 VDC	NON ATEX	E321H11-2995-481865C4	E321H11-2995-481865A2	E321H11-2995-481865A5
E321H11-2995-4958703D	220-230/50 HZ	2-22	E321H11-2995-495870C4	E321H11-2995-495870A2	E321H11-2995-495870A5
E321H11-2995-495870C2	24 VDC	2-22	E321H11-2995-495870C4	E321H11-2995-495870A2	E321H11-2995-495870A5
E321H11-495905C2	24 VDC	1-21	E321H11-495905C4	E321H11-495905A2	-
E321H11-495905F4	230/50 HZ	1-21	E321H11-495905C4	E321H11-495905A2	-
E321H13-2995-4818653D	220-230/50 HZ	NON ATEX	E321H13-2995-481865C4	E321H13-2995-481865A2	E321H13-2995-481865A5
E321H13-2995-481865C2	24 VDC	NON ATEX	E321H13-2995-481865C4	E321H13-2995-481865A2	E321H13-2995-481865A5
E321H13-2995-4958703D	220-230/50 HZ	2-22	E321H13-2995-495870C4	E321H13-2995-495870A2	E321H13-2995-495870A5
E321H13-2995-495870C2	24 VDC	2-22	E321H13-2995-495870C4	E321H13-2995-495870A2	E321H13-2995-495870A5
E321H13-495905C2	24 VDC	1-21	E321H13-495905C4	E321H13-495905A2	-
E321H13-495905F4	230/50 HZ	1-21	E321H13-495905C4	E321H13-495905A2	-
E321H15-2995-4818653D	220-230/50 HZ	NON ATEX	E321H15-2995-481865C4	E321H15-2995-481865A2	E321H15-2995-481865A5
E321H15-2995-481865C2	24 VDC	NON ATEX	E321H15-2995-481865C4	E321H15-2995-481865A2	E321H15-2995-481865A5
E321H15-2995-492425C2	24 VDC	NON ATEX	-	E321H15-2995-492425A2	-
E321H15-2995-4958703D	220-230/50 HZ	2-22	E321H15-2995-495870C4	E321H15-2995-495870A2	E321H15-2995-495870A5
E321H15-2995-495870C2	24 VDC	2-22	E321H15-2995-495870C4	E321H15-2995-495870A2	E321H15-2995-495870A5
E321H15-495905C2	24 VDC	1-21	E321H15-495905C4	E321H15-495905A2	-
E321H15-495905F4	230/50 HZ	1-21	E321H15-495905C4	E321H15-495905A2	-
E321K10-2995-4818653D	220-230/50 HZ	NON ATEX	E321K10-2995-481865C4	E321K10-2995-481865A2	E321K10-2995-481865A5
E321K10-2995-481865C2	24 VDC	NON ATEX	E321K10-2995-481865C4	E321K10-2995-481865A2	E321K10-2995-481865A5
E321K10-2995-4958703D	220-230/50 HZ	2-22	E321K10-2995-495870C4	E321K10-2995-495870A2	E321K10-2995-495870A5
E321K10-2995-495870C2	24 VDC	2-22	E321K10-2995-495870C4	E321K10-2995-495870A2	E321K10-2995-495870A5
E321K10-495905C2	24 VDC	1-21	E321K10-495905C4	E321K10-495905A2	-
E321K10-495905F4	230/50 HZ	1-21	E321K10-495905C4	E321K10-495905A2	-



MORE VOLTAGES

Solenoid Valve	Voltage	ATEX	48 Vdc	24 V / 50 Hz	110 V / 50 Hz
E321K13-2995-4818653D	220-230/50 HZ	NON ATEX	E321K13-2995-481865C4	E321K13-2995-481865A2	E321K13-2995-481865A5
E321K13-2995-481865C2	24 VDC	NON ATEX	E321K13-2995-481865C4	E321K13-2995-481865A2	E321K13-2995-481865A5
E321K13-2995-4958703D	220-230/50 HZ	2-22	E321K13-2995-495870C4	E321K13-2995-495870A2	E321K13-2995-495870A5
E321K13-2995-495870C2	24 VDC	2-22	E321K13-2995-495870C4	E321K13-2995-495870A2	E321K13-2995-495870A5
E321K13-495905C2	24 VDC	1-21	E321K13-495905C4	E321K13-495905A2	-
E321K13-495905F4	230/50 HZ	1-21	E321K13-495905C4	E321K13-495905A2	-
E321K15-2995-4818653D	220-230/50 HZ	NON ATEX	E321K15-2995-481865C4	E321K15-2995-481865A2	E321K15-2995-481865A5
E321K15-2995-481865C2	24 VDC	NON ATEX	E321K15-2995-481865C4	E321K15-2995-481865A2	E321K15-2995-481865A5
E321K15-2995-492425C2	24 VDC	NON ATEX	-	E321K15-2995-492425A2	-
E321K15-2995-4958703D	220-230/50 HZ	2-22	E321K15-2995-495870C4	E321K15-2995-495870A2	E321K15-2995-495870A5
E321K15-2995-495870C2	24 VDC	2-22	E321K15-2995-495870C4	E321K15-2995-495870A2	E321K15-2995-495870A5
E321K15-495905C2	24 VDC	1-21	E321K15-495905C4	E321K15-495905A2	-
E321K15-495905F4	230/50 HZ	1-21	E321K15-495905C4	E321K15-495905A2	-
E331B01-2995-4818653D	220-230/50 HZ	NON ATEX	E331B01-2995-481865C4	E331B01-2995-481865A2	E331B01-2995-481865A5
E331B01-2995-481865C2	24 VDC	NON ATEX	E331B01-2995-481865C4	E331B01-2995-481865A2	E331B01-2995-481865A5
E331B01-2995-4958703D	220-230/50 HZ	2-22	E331B01-2995-495870C4	E331B01-2995-495870A2	E331B01-2995-495870A5
E331B01-2995-495870C2	24 VDC	2-22	E331B01-2995-495870C4	E331B01-2995-495870A2	E331B01-2995-495870A5
E331B01-495905C2	24 VDC	1-21	E331B01-495905C4	E331B01-495905A2	-
E331B01-495905F4	230/50 HZ	1-21	E331B01-495905C4	E331B01-495905A2	-
E331B21-2995-4818653D	220-230/50 HZ	NON ATEX	E331B21-2995-481865C4	E331B21-2995-481865A2	E331B21-2995-481865A5
E331B21-2995-481865C2	24 VDC	NON ATEX	E331B21-2995-481865C4	E331B21-2995-481865A2	E331B21-2995-481865A5
E331B21-2995-4958703D	220-230/50 HZ	2-22	E331B21-2995-495870C4	E331B21-2995-495870A2	E331B21-2995-495870A5
E331B21-2995-495870C2	24 VDC	2-22	E331B21-2995-495870C4	E331B21-2995-495870A2	E331B21-2995-495870A5
E331B21-495905C2	24 VDC	1-21	E331B21-495905C4	E331B21-495905A2	-
E331B21-495905F4	230/50 HZ	1-21	E331B21-495905C4	E331B21-495905A2	-
E331B74-2995-4818653D	220-230/50 HZ	NON ATEX	E331B74-2995-481865C4	E331B74-2995-481865A2	E331B74-2995-481865A5
E331B74-2995-481865C2	24 VDC	NON ATEX	E331B74-2995-481865C4	E331B74-2995-481865A2	E331B74-2995-481865A5
E331B74-2995-4958703D	220-230/50 HZ	2-22	E331B74-2995-495870C4	E331B74-2995-495870A2	E331B74-2995-495870A5
E331B74-2995-495870C2	24 VDC	2-22	E331B74-2995-495870C4	E331B74-2995-495870A2	E331B74-2995-495870A5
E331B74-495905C2	24 VDC	1-21	E331B74-495905C4	E331B74-495905A2	-
E331B74-495905F4	230/50 HZ	1-21	E331B74-495905C4	E331B74-495905A2	-
E331L21-2995-4818653D	220-230/50 HZ	NON ATEX	E331L21-2995-481865C4	E331L21-2995-481865A2	E331L21-2995-481865A5
E331L21-2995-481865C2	24 VDC	NON ATEX	E331L21-2995-481865C4	E331L21-2995-481865A2	E331L21-2995-481865A5
E331L21-2995-4958703D	220-230/50 HZ	2-22	E331L21-2995-495870C4	E331L21-2995-495870A2	E331L21-2995-495870A5
E331L21-2995-495870C2	24 VDC	2-22	E331L21-2995-495870C4	E331L21-2995-495870A2	E331L21-2995-495870A5
E331L21-495905C2	24 VDC	1-21	E331L21-495905C4	E331L21-495905A2	-
E331L21-495905F4	230/50 HZ	1-21	E331L21-495905C4	E331L21-495905A2	-
E332B01-2995-4818653D	220-230/50 HZ	NON ATEX	E332B01-2995-481865C4	E332B01-2995-481865A2	E332B01-2995-481865A5
E332B01-2995-481865C2	24 VDC	NON ATEX	E332B01-2995-481865C4	E332B01-2995-481865A2	E332B01-2995-481865A5
E332B01-2995-4958703D	220-230/50 HZ	2-22	E332B01-2995-495870C4	E332B01-2995-495870A2	E332B01-2995-495870A5
E332B01-2995-495870C2	24 VDC	2-22	E332B01-2995-495870C4	E332B01-2995-495870A2	E332B01-2995-495870A5
E332B01-495905C2	24 VDC	1-21	E332B01-495905C4	E332B01-495905A2	-
E332B01-495905F4	230/50 HZ	1-21	E332B01-495905C4	E332B01-495905A2	-
E332B21-2995-4818653D	220-230/50 HZ	NON ATEX	E332B21-2995-481865C4	E332B21-2995-481865A2	E332B21-2995-481865A5
E332B21-2995-481865C2	24 VDC	NON ATEX	E332B21-2995-481865C4	E332B21-2995-481865A2	E332B21-2995-481865A5
E332B21-2995-4958703D	220-230/50 HZ	2-22	E332B21-2995-495870C4	E332B21-2995-495870A2	E332B21-2995-495870A5
E332B21-2995-495870C2	24 VDC	2-22	E332B21-2995-495870C4	E332B21-2995-495870A2	E332B21-2995-495870A5
E332B21-495905C2	24 VDC	1-21	E332B21-495905C4	E332B21-495905A2	-
E332B21-495905F4	230/50 HZ	1-21	E332B21-495905C4	E332B21-495905A2	-

MORE PRODUCTS



OTHER PRODUCTS

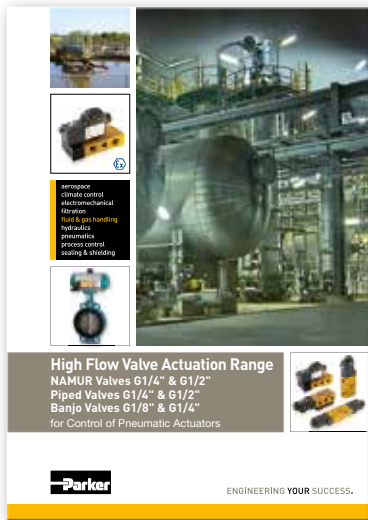

aerospace
 climate control
 electromechanical
 filtration
 fluid & gas handling
 hydraulics
 pneumatics
 process control
 sealing & shielding

High Flow Valve Actuation Range
 NAMUR Valves G1/4" & G1/2"
 Piped Valves G1/4" & G1/2"
 Banjo Valves G1/8" & G1/4"
 for Control of Pneumatic Actuators

Parker ENGINEERING YOUR SUCCESS.



aerospace
 climate control
 electromechanical
 filtration
 fluid & gas handling
 hydraulics
 pneumatics
 process control
 sealing & shielding

Fluid Control Solenoid Valves for Process Market

Parker ENGINEERING YOUR SUCCESS.

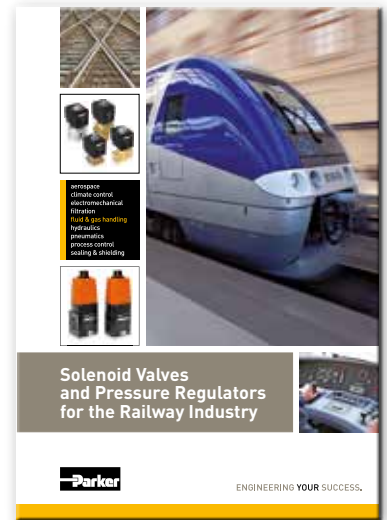

aerospace
 climate control
 electromechanical
 filtration
 fluid & gas handling
 hydraulics
 pneumatics
 process control
 sealing & shielding

Solenoid Valves and Pressure Regulators for the Railway Industry

Parker ENGINEERING YOUR SUCCESS.

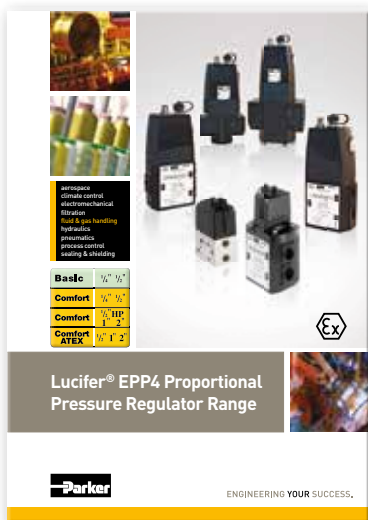

aerospace
 climate control
 electromechanical
 filtration
 fluid & gas handling
 hydraulics
 pneumatics
 process control
 sealing & shielding

Basic	1/2" 3/4" 1"
Comfort	1/2" 3/4" 1"
Comfort	1/2" 3/4" 1"
ATEX	1/2" 1" 2"

Lucifer® EPP4 Proportional Pressure Regulator Range

Parker ENGINEERING YOUR SUCCESS.



aerospace
 climate control
 electromechanical
 filtration
 fluid & gas handling
 hydraulics
 pneumatics
 process control
 sealing & shielding

FCDE Transportation Overview
 Truck, Bus, Railway & Marine Control Solutions

Parker ENGINEERING YOUR SUCCESS.

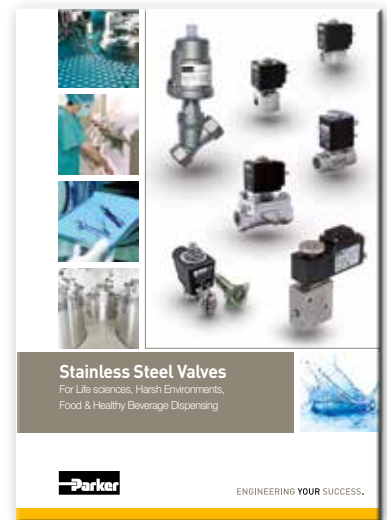

Stainless Steel Valves
 For Life sciences, Harsh Environments, Food & Healthy Beverage Dispensing

Parker ENGINEERING YOUR SUCCESS.

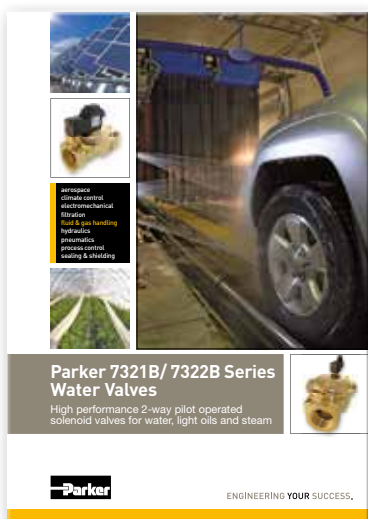

aerospace
 climate control
 electromechanical
 filtration
 fluid & gas handling
 hydraulics
 pneumatics
 process control
 sealing & shielding

Parker 7321B/ 7322B Series Water Valves
 High performance 2-way pilot operated solenoid valves for water, light oils and steam

Parker ENGINEERING YOUR SUCCESS.



FOR MORE PRODUCTS
OR MORE VOLTAGES,
PLEASE CONTACT YOUR PARKER
REPRESENTATIVE

**MORE
PRODUCTS**



TECHNICAL INFORMATION ABOUT SOLENOID VALVES

General Information

Solenoid valves are electro-mechanical devices used for interrupting or diverting the flow of fluids by opening or closing one or more orifices.

The solenoid valve is a combination of three basic components:

1. An electromagnet consisting of a solenoid (windings) and a magnetic yoke.
2. A pilot with a moveable plunger (which, in some cases directly opens and closes the valve).
3. A valve body with an orifice opened or closed by plunger or diaphragm to enable or prevent flow of the medium.

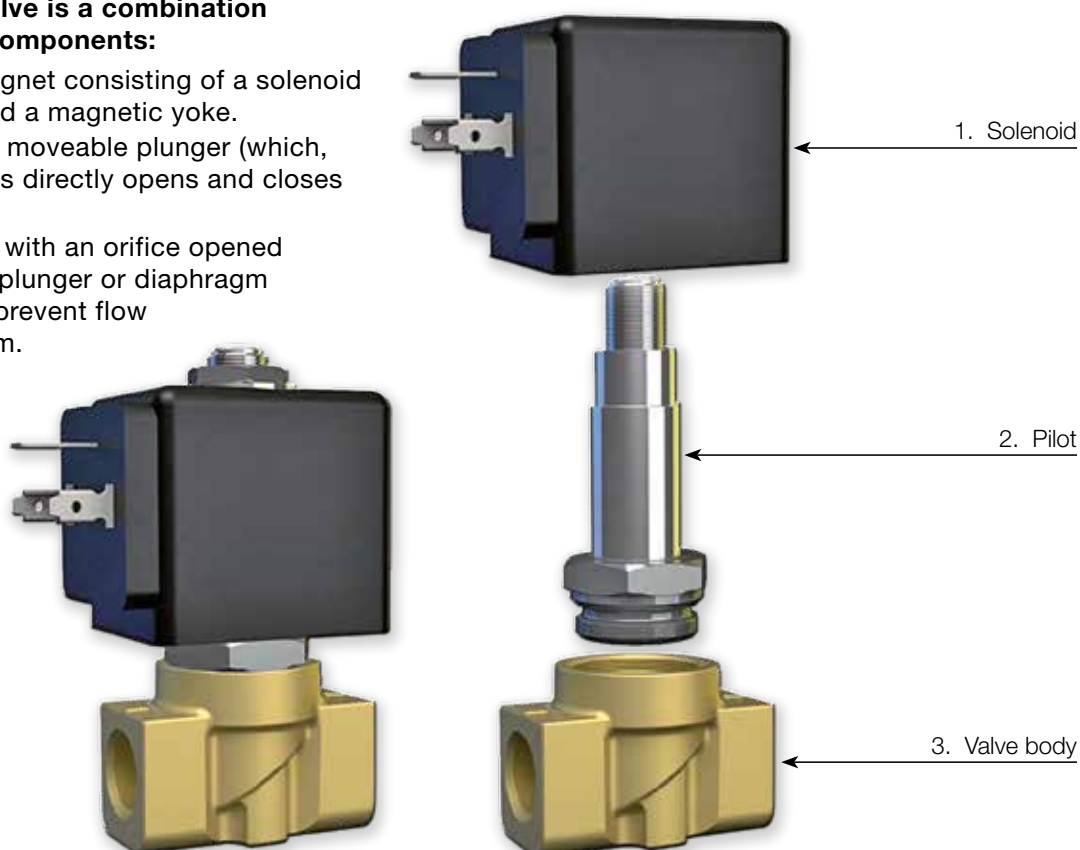

Operating principles

The term solenoid refers to operator and coil, also known as pilot or magnetic actuator.

The coil consists of copper wire wound on a support reel. When electric current is applied into the coil, magnetic flow lines are generated which are stronger in the coil center.

This magnetic flow raises the moveable plunger in the coil until it brings it into contact with the pole piece. The valve body has an orifice through which the fluid flows when the valve is open.

The moveable plunger has an integral seat which when the solenoid coil is energised, moves off the valve (direct operated) orifice or diaphragm (pilot operated) orifice opening the valve.

When the coil is de-energised, a return spring brings the plunger back to the original closing position, thus cutting off the flow of the fluid.

BASIC COMPONENTS OF A SOLENOID VALVE

Valve body:	Main part of the solenoid valve including ports, seat and orifices.
Solenoid tube assembly:	Cylinder, in stainless steel, hermetically sealed and closed at one extremity. It is the guide channel of the moveable plunger which is moved magnetically. The solenoid coil is fitted on the external side of the enclosing tube.
Moveable plunger:	Made by ferritic stainless steel, it is attracted by the solenoid magnetic field and slides inside the tube.
Plunger spring (or return spring):	Used to hold the moveable plunger in position and to return it when de-energized.
Seat seal:	Part of the moveable plunger, it is used to close a valves main orifice or pilot orifice.
Electromagnet (or solenoid coil):	Electrical part consisting of a copper windings (solenoid) along, with a magnetic yoke (armature), when electric current flows through, it generates a magnetic field attracting the moveable plunger.
Housing:	Part that contains and protects the coil.
Yoke:	Metalic case surrounding the coil and concentrating electro-magnetic force on the moveable plunger.

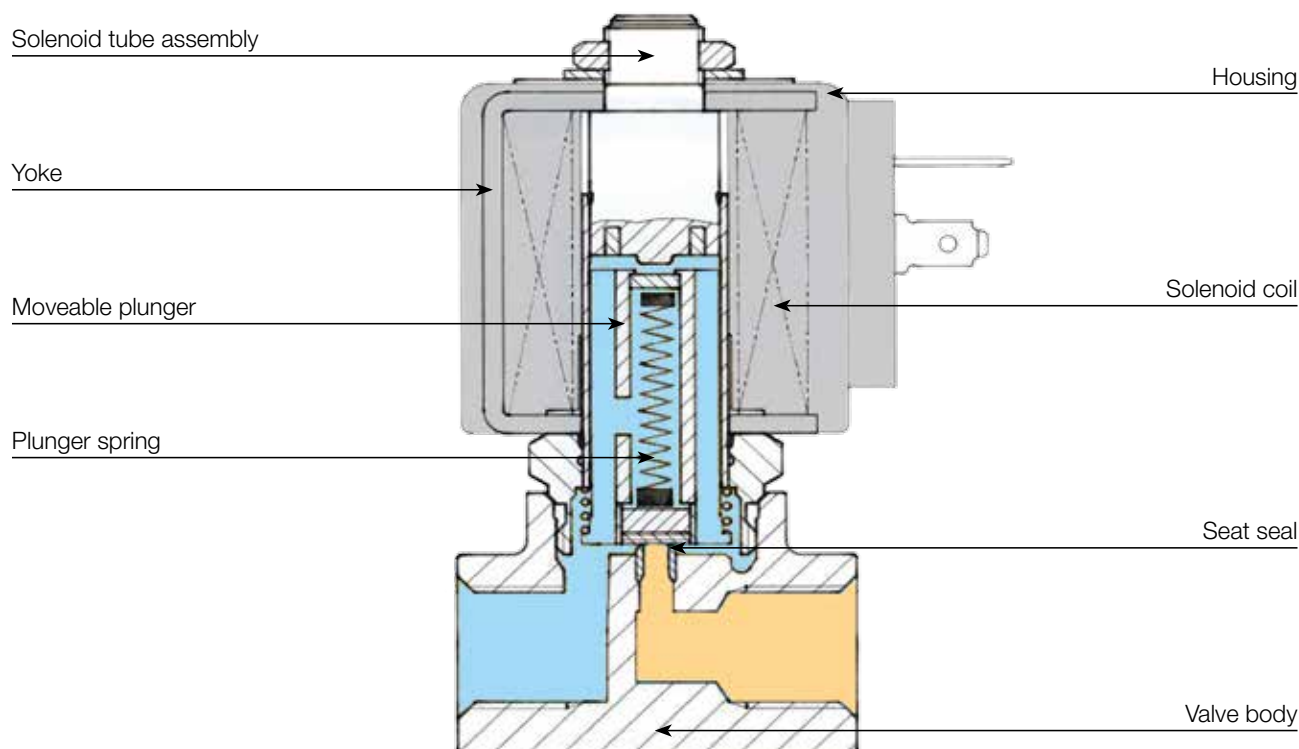

TECHNICAL VOCABULARY USED IN TABLES

NORMALLY CLOSED

Port size	Orifice Ø	Flow factors			Seat Seal	Atex Zone	Operating Pressure Differential		Fluid Temp.		Power	Voltage	Solenoid Valve Order Number
		Kv l/min	KV m³/h	Qn l/min			Min bar	Max bar	Min °C	Max °C			
BSP	mm										W		

The basic technical features of each solenoid valve are indicated in the tables, the terminology used is shown and explained below.

Actuation:	The mechanical method used to control the flow.	Atex Zone:	The hazardous areas are classified in zones based on the frequency of the occurrence and the duration of an explosive gas or dust environment as follows: <ul style="list-style-type: none"> • Zone 1(gas)-21(dust): An area in which an explosive gas (dust) atmosphere is present likely to occur in normal operation (~10 to 999 h/y). • Zone 2(gas)-22(dust): An area in which an explosive gas (dust) atmosphere is not likely to occur and if it does occur it will exist for short period only (~1 to 10 h/y).
Body:	Main part of the solenoid valve with the ports, seats and orifice needed.	Minimum Operating Pressure Differential:	The lowest differential pressure required for operation (bar).
Function:	The way the valve operates when de-energised.	Maximum Operating Pressure Differential (MOPD):	The highest working differential pressure 90% of the rated voltage (-10% Vn) applied to the solenoid coil (for AC) and 95% of the rated voltage (-5% Vn) (for DC).
Specification:	The main describing attribute for the considered product.	Fluid Temperature:	Minimum and Maximum admissible for the media used (°C).
Port Size:	Fitting dimensions are defined as threaded in inches (G), in BSP or Sub-base, when a flat interface for ports is adopted.	Power:	The rated power under normal conditions of the solenoid expressed in W.
Orifice (mm):	Main orifice diameter in millimeters (nominal diameter).	Voltage:	Indicates the voltage type required to energise the coil of the solenoid valve.
Actuator size (mm):	The diameter in mm of the pneumatically driven piston head of an Angle Seat Valve.	Pilot Control Pressure:	The pressure to apply to the inlet port of the actuator for an Angle Seat Valve.
Pmax (bar):	Maximum working pressure for the valve.		
Flow Factors:	Define the quantity of fluid which flows through the solenoid valve with a pressure drop of 1 bar during one minute. For liquids Kv and KV are expressed in l/min and m³/h. For air and gases Qn is expressed in l/min.		
Seat seal:	Material used for the seat discs.		
Flow Direction:	Specifies the direction of the main flow into an Angle Seat Valve. Flow direction is "over seat" for a standard valve and "under seat" for an Anti Water Hammer valve.		

The liquid flow through a pipe or a valve is given by:

$$Q = Kv \cdot \sqrt{\frac{\Delta P}{\gamma}}$$

Where

- Q** = Flow [l/min]
- ΔP** = Differential Pressure [bar]
- γ** = Density of the fluid [kg/dm³]
(water γ = 1 [kg/dm³])
- kv** = Flow Factor [l/min]



TECHNICAL INFORMATION ABOUT VALVES

Solenoid Valves

Solenoid valves are electrically operated devices used to control flow. The most common types of solenoid valve are:



Magnalift Valves



Direct Operated Valves

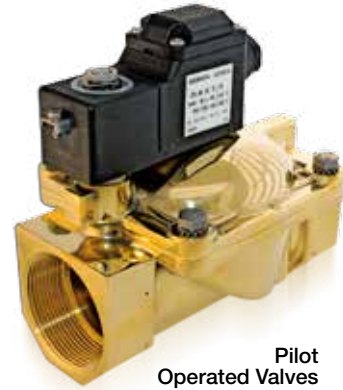

Pilot Operated Valves

Angle Seat Valves

An angle seat valve is actuated by a pneumatically driven piston and is capable to handle slurry solutions with particles or corrosive solutions at high temperature up to 180°C and operating pressure up to 16 Bar.



Angle Seat Valves

Area of operation:

Each valve principle, as described in the previous pages, has a defined area of operation related to its pressure and flow capabilities. The following graph shows which type of valve is suitable in our complete range for a certain situation.

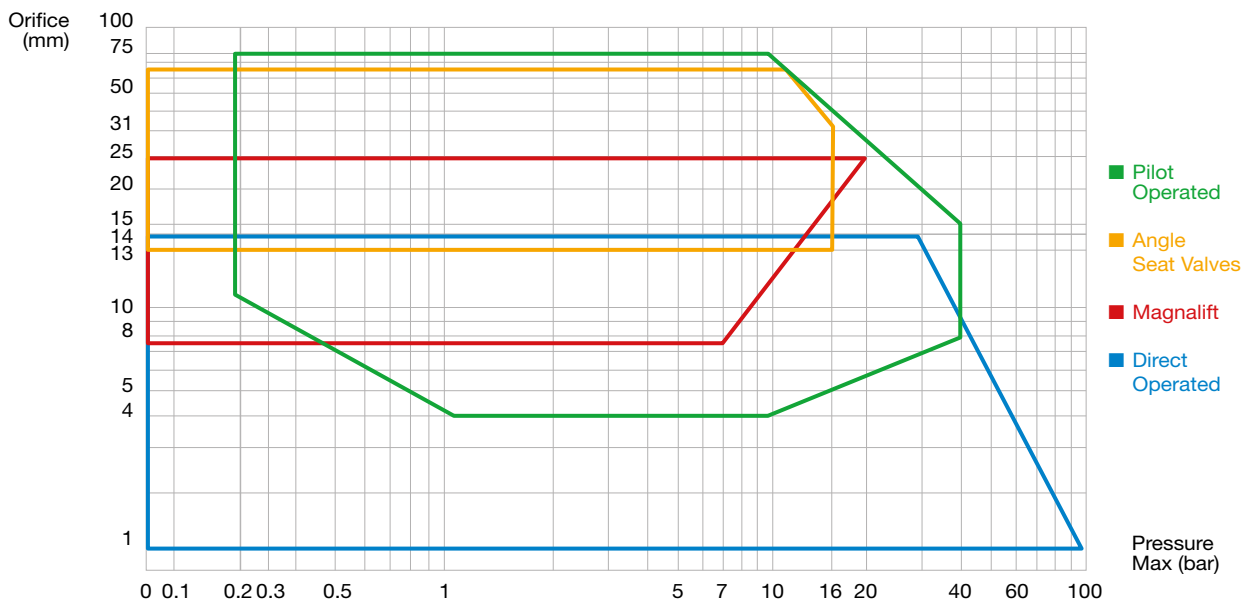

Areas of operation of Parker solenoid valves.



INDEX FOR VALVES

Valve Reference	Page	Valve Reference	Page	Valve Reference	Page	Valve Reference	Page
121K01-2995-4818653D	13	121V5163-2995-481865C2	55	131M14-8993-495865C2	72	133T23-2995-481865C2	82
121K01-2995-481865C2	13	121V5363-2995-4818653D	55	131M15-4826063D	72	133T23-2995-4958703D	82
121K01-2995-492425C2	13	121V5363-2995-481865C2	55	131M15-482606C2	72	133T23-2995-495870C2	82
121K01-2995-4958703D	13	121V5463-2995-4818653D	55	131M15-8993-4889803D	72	133T23-495905C2	82
121K01-2995-495870C2	13	121V5463-2995-481865C2	55	131M15-8993-488980C2	72	133T23-495905F4	82
121K01-495905C2	13	122K83-2995-4818653D	17	131M15-8993-4958653D	72	133T2301-2995-4818653D	83
121K01-495905F4	13	122K83-2995-481865C2	17	131M15-8993-495865C2	72	133T2301-2995-481865C2	83
121K02-2995-4818653D	13	122K83-2995-4958703D	17	131T21-2995-4818653D	76	133T2301-2995-4958703D	83
121K02-2995-481865C2	13	122K83-2995-495870C2	17	131T21-2995-481865C2	76	133T2301-2995-495870C2	83
121K02-2995-492425C2	13	122K83-495905C2	17	131T21-2995-4958703D	76	133T2301-495905C2	83
121K02-2995-492425F4	13	122K83-495905F4	17	131T21-2995-495870C2	76	133T2301-495905F4	83
121K02-2995-4958703D	13	122K8306-2995-4818653D	17	131T21-495905C2	76	133V5406-2995-4818653D	85
121K02-2995-495870C2	13	122K8306-2995-481865C2	17	131T21-495905F4	76	133V5406-2995-481865C2	85
121K02-495905C2	13	122K8306-2995-4958703D	17	131T23-2995-4818653D	76	133V5406-2995-4958703D	85
121K02-495905F4	13	122K8306-2995-495870C2	17	131T23-2995-481865C2	76	133V5406-2995-495870C2	85
121K0250-2995-4818653D	16	122K8306-495905C2	17	131T23-2995-4958703D	76	133V5406-495905C2	85
121K0250-2995-481865C2	16	122K8306-495905F4	17	131T23-2995-495870C2	76	133V5406-495905F4	85
121K0250-2995-4958703D	16	122K84-2995-4818653D	17	131T23-495905C2	76	221G13-2995-4818653D	33
121K0250-2995-495870C2	16	122K84-2995-481865C2	17	131T23-495905F4	76	221G13-2995-492425C2	33
121K0250-495905C2	16	122K84-2995-4958703D	17	131T2301-2995-4818653D	77	221G13-2995-4958703D	33
121K0250-495905F4	16	122K84-2995-495870C2	17	131T2301-2995-481865C2	77	221G13-495905F4	33
121K0706-2995-4818653D	11	122K84-495905C2	17	131T2301-2995-4958703D	77	221G1303-2995-4818653D	57
121K0706-2995-481865C2	11	122K84-495905F4	17	131T2301-2995-495870C2	77	221G15-2995-4818653D	33
121K0706-2995-492425C2	11	131B04-482605C2	60	131T2301-495905C2	77	221G15-2995-492425C2	33
121K0706-2995-4958703D	11	131B04-496131C2	60	131T2301-495905F4	77	221G15-2995-4958703D	33
121K0706-2995-495870C2	11	131B04-496131P9	60	131V5306-2995-4818653D	84	221G15-495905F4	33
121K0706-495905C2	11	131B04-496637C2	60	131V5306-2995-481865C2	84	221G1503-2995-4818653D	57
121K0706-495905F4	11	131B04-496637P9	60	131V5306-2995-4958703D	84	221G1530-2995-481865C2	33
121K3106-2995-4818653D	14	131B14-482605C2	60	131V5306-2995-495870C2	84	221G1530-2995-495870C2	33
121K3106-2995-481865C2	14	131B14-496131C2	60	131V5306-495905C2	84	221G1530-495905C2	33
121K3106-2995-492425C2	14	131B14-496131P9	60	131V5306-495905F4	84	221G16-2995-4818653D	34
121K3106-2995-4958703D	14	131B14-496637C2	60	132K03-2995-4818653D	78	221G16-2995-492425C2	34
121K3106-2995-495870C2	14	131B14-496637P9	60	132K03-2995-481865C2	78	221G16-2995-4958703D	34
121K3106-495905C2	14	131K1650-2995-4818653D	75	132K03-2995-4958703D	78	221G16-495905F4	34
121K3106-495905F4	14	131K1650-2995-481865C2	75	132K03-2995-495870C2	78	221G1603-2995-4818653D	57
121K3306-2995-4818653D	14	131K1650-2995-4958703D	75	132K03-495905C2	78	221G17-2995-4818653D	34
121K3306-2995-481865C2	14	131K1650-2995-495870C2	75	132K03-495905F4	78	221G17-2995-492425C2	34
121K3306-2995-492425C2	14	131K1650-495905C2	75	132K06-2995-4818653D	78	221G17-2995-4958703D	34
121K3306-2995-492425F4	14	131K1650-495905F4	75	132K06-2995-481865C2	78	221G17-495905F4	34
121K3306-2995-4958703D	14	131M14-482606C2	72	132K06-2995-4958703D	78	221G1703-2995-4818653D	57
121K3306-2995-495870C2	14	131M14-4826063D	72	132K06-2995-495870C2	78	221G21-2995-4818653D	34
121K3306-495905C2	14	131M14-8993-4889803D	72	132K06-495905C2	78	221G21-2995-492425C2	34
121K3306-495905F4	14	131M14-8993-488980C2	72	132K06-495905F4	78	221G21-2995-4958703D	34
121V5163-2995-4818653D	55	131M14-8993-4958653D	72	133T23-2995-4818653D	82	221G21-495905F4	34



INDEX FOR VALVES

Valve Reference	Page	Valve Reference	Page	Valve Reference	Page	Valve Reference	Page
221G2130-2995-481865C2	34	321K36-8993-4889803D	24	322K4106-495905C2	29	341P03-496131C2	63
221G2130-2995-495870C2	34	321K36-8993-488980C2	24	322K4106-495905F4	29	341P03-496131P9	63
221G2130-495905C2	34	321K36-8993-4958653D	24	322K4506-2995-4818653D	29	341P03-496637C2	63
221G25-2995-4818653D	33	321K36-8993-495865C2	24	322K4506-2995-481865C2	29	341P03-496637P9	63
221G25-2995-492425C2	33	321K3606-4826063D	24	322K4506-2995-4958703D	29	341P04-496131C2	63
221G25-2995-4958703D	33	321K3606-482606C2	24	322K4506-2995-495870C2	29	341P04-496131P9	63
221G25-495905F4	33	321K3606-8993-4889803D	24	322K4506-495905C2	29	341P04-496637C2	63
221G2530-2995-481865C2	33	321K3606-8993-488980C2	24	322K4506-495905F4	29	341P04-496637P9	63
221G2530-2995-495870C2	33	321K3606-8993-4958653D	24	322K4606-2995-4818653D	29	347N03-496131C2	68
221G2530-495905C2	33	321K3606-8993-495865C2	24	322K4606-2995-481865C2	29	347N03-496131P9	68
221G26-2995-4818653D	34	321K37-4826063D	25	322K4606-2995-4958703D	29	347N03-496637C2	68
221G26-2995-492425C2	34	321K37-482606C2	25	322K4606-2995-495870C2	29	347N03-496637P9	68
221G26-2995-4958703D	34	321K37-8993-4889803D	25	322K4606-495905C2	29	347N04-496131C2	68
221G26-495905F4	34	321K37-8993-488980C2	25	322K4606-495905F4	29	347N04-496131P9	68
221S10F-2995-4818653D	35	321K37-8993-4958653D	25	331N04-496131C2	62	347N04-496637C2	68
221S15F-2995-4818653D	35	321K37-8993-495865C2	25	331N04-496131P9	62	347N04-496637P9	68
221S20F-2995-4818653D	35	321K3706-4826063D	25	331N04-496637C2	62	347N33-2995-4818653D	67
221S25F-2995-4818653D	35	321K3706-482606C2	25	331N04-496637P9	62	347N33-2995-481865C2	67
321K3106-4826063D	22	321K3706-8993-4889803D	25	331N34-2995-4818653D	61	347N33-2995-4958703D	67
321K3106-482606C2	22	321K3706-8993-488980C2	25	331N34-2995-481865C2	61	347N33-2995-495870C2	67
321K3106-8993-4889803D	22	321K3706-8993-4958653D	25	331N34-2995-4958703D	61	347N33-495905C2	67
321K3106-8993-488980C2	22	321K3706-8993-495865C2	25	331N34-2995-495870C2	61	347N33-495905F4	67
321K3106-8993-4958653D	22	322G75-2995-4818653D	31	331N34-495905C2	61	347N34-2995-4818653D	67
321K3106-8993-495865C2	22	322G75-2995-481865C2	31	331N34-495905F4	61	347N34-2995-481865C2	67
321K3306-4826063D	22	322G75-2995-4958703D	31	341N04-496131C2	66	347N34-2995-4958703D	67
321K3306-482606C2	22	322G75-2995-495870C2	31	341N04-496131P9	66	347N34-2995-495870C2	67
321K3306-8993-4889803D	22	322G75-495905C2	31	341N04-496637C2	66	347N34-495905C2	67
321K3306-8993-488980C2	22	322G75-495905F4	31	341N04-496637P9	66	347N34-495905F4	67
321K3306-8993-4958653D	22	322H75-2995-4818653D	30	341N05-496131C2	70	347P03-496131C2	64
321K3306-8993-495865C2	22	322H75-2995-481865C2	30	341N05-496131P9	70	347P03-496131P9	64
321K35-4826063D	23	322H75-2995-4958703D	30	341N05-496637C2	70	347P03-496637C2	64
321K35-482606C2	23	322H75-2995-495870C2	30	341N05-496637P9	70	347P03-496637P9	64
321K35-8993-4889803D	23	322H75-495905C2	30	341N34-2995-4818653D	65	347P04-496131C2	64
321K35-8993-488980C2	23	322H75-495905F4	30	341N34-2995-481865C2	65	347P04-496131P9	64
321K35-8993-4958653D	23	322H7506-2995-4818653D	30	341N34-2995-4958703D	65	347P04-496637C2	64
321K35-8993-495865C2	23	322H7506-2995-481865C2	30	341N34-2995-495870C2	65	347P04-496637P9	64
321K3506-4826063D	23	322H7506-2995-4958703D	30	341N34-495905C2	65	550000DIS	18
321K3506-482606C2	23	322H7506-2995-495870C2	30	341N34-495905F4	65	550001DIS	18
321K3506-8993-4889803D	23	322H7506-495905C2	30	341N35-2995-4818653D	69	550002DIS	18
321K3506-8993-488980C2	23	322H7506-495905F4	30	341N35-2995-481865C2	69	550003DIS	18
321K3506-8993-4958653D	23	322K4106-2995-4818653D	29	341N35-2995-4958703D	69	550004DIS	18
321K3506-8993-495865C2	23	322K4106-2995-481865C2	29	341N35-2995-495870C2	69	550005DIS	18
321K36-4826063D	24	322K4106-2995-4958703D	29	341N35-495905C2	69	550006DIS	18
321K36-482606C2	24	322K4106-2995-495870C2	29	341N35-495905F4	69	550007DIS	18

INDEX FOR VALVES

Valve Reference	Page	Valve Reference	Page	Valve Reference	Page	Valve Reference	Page
550008DIS	18	550052DIS	51	550100DIS	9	550192DIS	49
550009DIS	18	550053DIS	51	550101DIS	56	550193DIS	8
550010DIS	18	550054DIS	51	550102DIS	56	550194DIS	8
550011DIS	18	550055DIS	51	550103DIS	56	550195DIS	9
550012DIS	19	550056DIS	49	550104DIS	56	550196DIS	9
550013DIS	19	550057DIS	49	550105DIS	26	550197DIS	44
550014DIS	86	550058DIS	8	550106DIS	26	550198DIS	44
550015DIS	86	550059DIS	8	550107DIS	26	550199DIS	44
550016DIS	86	550060DIS	9	550108DIS	26	550200DIS	44
550017DIS	86	550061DIS	9	550109DIS	26	550201DIS	44
550018DIS	43	550062DIS	72	550110DIS	26	550202DIS	44
550019DIS	43	550063DIS	72	550111DIS	26	550203DIS	45
550020DIS	43	550064DIS	32	550112DIS	26	550204DIS	45
550021DIS	43	550065DIS	32	550119DIS	43	550205DIS	45
550022DIS	47	550066DIS	32	550120DIS	43	550206DIS	45
550023DIS	47	550071DIS	32	550135DIS	42	550207DIS	46
550024DIS	43	550072DIS	56	550136DIS	42	550208DIS	46
550025DIS	43	550073DIS	56	550141DIS	49	550209DIS	46
550026DIS	44	550074DIS	56	550142DIS	49	550210DIS	46
550027DIS	44	550075DIS	56	550143DIS	50	550211DIS	44
550028DIS	45	550076DIS	56	550144DIS	50	550212DIS	44
550029DIS	45	550077DIS	56	550145DIS	50	550213DIS	45
550030DIS	45	550078DIS	80	550146DIS	50	550214DIS	45
550031DIS	45	550079DIS	80	550147DIS	51	550215DIS	46
550032DIS	46	550080DIS	80	550148DIS	51	550216DIS	46
550033DIS	46	550081DIS	80	550149DIS	51	550217DIS	46
550034DIS	46	550082DIS	80	550150DIS	51	550218DIS	46
550035DIS	46	550083DIS	80	550151DIS	49	550219DIS	72
550036DIS	42	550084DIS	54	550152DIS	49	550220DIS	72
550037DIS	42	550085DIS	54	550159DIS	43	550221DIS	54
550038DIS	42	550086DIS	54	550160DIS	43	550222DIS	54
550039DIS	42	550087DIS	54	550175DIS	42	E121K03-2995-4818653D	12
550040DIS	42	550088DIS	54	550176DIS	42	E121K03-2995-481865C2	12
550041DIS	42	550089DIS	54	550181DIS	49	E121K03-2995-4958703D	12
550042DIS	48	550090DIS	74	550182DIS	49	E121K03-2995-495870C2	12
550043DIS	48	550091DIS	9	550183DIS	50	E121K03-495905C2	12
550044DIS	48	550092DIS	9	550184DIS	50	E121K03-495905F4	12
550045DIS	48	550093DIS	8	550185DIS	50	E121K0302-2995-4818653D	12
550046DIS	49	550094DIS	8	550186DIS	50	E121K0302-2995-481865C2	12
550047DIS	49	550095DIS	8	550187DIS	51	E121K0302-2995-4958703D	12
550048DIS	50	550096DIS	8	550188DIS	51	E121K0302-2995-495870C2	12
550049DIS	50	550097DIS	9	550189DIS	51	E121K0302-495905C2	12
550050DIS	50	550098DIS	9	550190DIS	51	E121K0302-495905F4	12
550051DIS	50	550099DIS	9	550191DIS	49	E121K0352-2995-4818653D	16



INDEX FOR VALVES

Valve Reference	Page	Valve Reference	Page	Valve Reference	Page	Valve Reference	Page
E121K0352-2995-481865C2	16	E131K03-2995-481865C2	74	E133K05-2995-495870C2	79	E321K15-2995-495870C2	21
E121K0352-2995-4958703D	16	E131K03-2995-4958703D	74	E133K05-495905C2	79	E321K15-495905C2	21
E121K0352-2995-495870C2	16	E131K03-2995-495870C2	74	E133K05-495905F4	79	E321K15-495905F4	21
E121K0352-495905C2	16	E131K03-495905C2	74	E133K06-2995-4818653D	79	PA10C1G3R032S	36
E121K0352-495905F4	16	E131K03-495905F4	74	E133K06-2995-481865C2	79	PA10C2G3R032S	36
E121K04-2995-4818653D	10	E131K0350-2995-4818653D	75	E133K06-2995-4958703D	79	PA10S1G3R050S	36
E121K04-2995-481865C2	10	E131K0350-2995-481865C2	75	E133K06-2995-495870C2	79	PA10S2G3R050S	38
E121K04-2995-4958703D	10	E131K0350-2995-4958703D	75	E133K06-495905C2	79	PA10SAG3R050S	36
E121K04-2995-495870C2	10	E131K0350-2995-495870C2	75	E133K06-495905F4	79	PA15C1G4R032S	36
E121K04-495905C2	10	E131K0350-495905C2	75	E321H11-2995-4818653D	27	PA15C2G4R032S	36
E121K04-495905F4	10	E131K0350-495905F4	75	E321H11-2995-481865C2	27	PA15S1G4R040S	36
E121K45-2995-4818653D	15	E131K04-2995-4818653D	73	E321H11-2995-4958703D	27	PA15S1G4R050A	39
E121K45-2995-481865C2	15	E131K04-2995-481865C2	73	E321H11-2995-495870C2	27	PA15S1G4R050S	36
E121K45-2995-4958703D	15	E131K04-2995-4958703D	73	E321H11-495905C2	27	PA15S2G4R050S	38
E121K45-2995-495870C2	15	E131K04-2995-495870C2	73	E321H11-495905F4	27	PA15SAG4R050A	39
E121K45-495905C2	15	E131K04-495905C2	73	E321H13-2995-4818653D	27	PA15SAG4R050S	36
E121K45-495905F4	15	E131K04-495905F4	73	E321H13-2995-481865C2	27	PA20C1G5R032S	37
E121K46-2995-4818653D	15	E131K0450-2995-4818653D	75	E321H13-2995-4958703D	27	PA20C2G5R032S	37
E121K46-2995-481865C2	15	E131K0450-2995-481865C2	75	E321H13-2995-495870C2	27	PA20S1G5R050A	39
E121K46-2995-492425C2	15	E131K0450-2995-4958703D	75	E321H13-495905C2	27	PA20S1G5R050S	37
E121K46-2995-492425F4	15	E131K0450-2995-495870C2	75	E321H13-495905F4	27	PA20S2G5R050S	38
E121K46-2995-4958703D	15	E131K0450-495905C2	75	E321H15-2995-4818653D	28	PA20SAG5R050A	39
E121K46-2995-495870C2	15	E131K0450-495905F4	75	E321H15-2995-481865C2	28	PA20SAG5R050S	37
E121K46-495905C2	15	E131K06-2995-4818653D	73	E321H15-2995-492425C2	28	PA25S1G6R050S	37
E121K46-495905F4	15	E131K06-2995-481865C2	73	E321H15-2995-4958703D	28	PA25S1G6R063S	37
E121K63-2995-4818653D	11	E131K06-2995-4958703D	73	E321H15-2995-495870C2	28	PA25S2G6R063S	38
E121K63-2995-481865C2	11	E131K06-2995-495870C2	73	E321H15-495905C2	28	PA25SAG6R063A	39
E121K63-2995-4958703D	11	E131K06-495905C2	73	E321H15-495905F4	28	PA25SAG6R063S	37
E121K63-2995-495870C2	11	E131K06-495905F4	73	E321K10-2995-4818653D	20	PA32S1G7R063S	37
E121K63-495905C2	11	E131K0650-2995-4818653D	75	E321K10-2995-481865C2	20	PA32S2G7R063S	38
E121K63-495905F4	11	E131K0650-2995-481865C2	75	E321K10-2995-4958703D	20	PA32SAG7R080S	37
E121K64-2995-4818653D	12	E131K0650-2995-4958703D	75	E321K10-2995-495870C2	20		
E121K64-2995-481865C2	12	E131K0650-2995-495870C2	75	E321K10-495905C2	20		
E121K64-2995-4958703D	12	E131K0650-495905C2	75	E321K10-495905F4	20		
E121K64-2995-495870C2	12	E131K0650-495905F4	75	E321K13-2995-4818653D	20		
E121K64-495905C2	12	E131K13-2995-4818653D	73	E321K13-2995-481865C2	20		
E121K64-495905F4	12	E131K13-2995-481865C2	73	E321K13-2995-4958703D	20		
E121K65-2995-4818653D	10	E131K13-2995-4958703D	73	E321K13-2995-495870C2	20		
E121K65-2995-481865C2	10	E131K13-2995-495870C2	73	E321K13-495905C2	20		
E121K65-2995-4958703D	10	E131K13-495905C2	73	E321K13-495905F4	20		
E121K65-2995-495870C2	10	E131K13-495905F4	73	E321K15-2995-4818653D	21		
E121K65-495905C2	10	E133K05-2995-4818653D	79	E321K15-2995-481865C2	21		
E121K65-495905F4	10	E133K05-2995-481865C2	79	E321K15-2995-492425C2	21		
E131K03-2995-4818653D	74	E133K05-2995-4958703D	79	E321K15-2995-4958703D	21		





Parker's Motion & Control Technologies

At Parker, we're guided by a relentless drive to help our customers become more productive and achieve higher levels of profitability by engineering the best systems for their requirements. It means looking at customer applications from many angles to find new ways to create value. Whatever the motion and control technology need, Parker has the experience, breadth of product and global reach to consistently deliver. No company knows more about motion and control technology than Parker. For further info call 00800 27 27 5374



Aerospace

Key Markets

Aftermarket services
Commercial transports
Engines
General & business aviation
Helicopters
Launch vehicles
Military aircraft
Missiles
Power generation
Regional transports
Unmanned aerial vehicles

Key Products

Control systems & actuation products
Engine systems & components
Fluid conveyance systems & components
Fluid metering, delivery & atomization devices
Fuel systems & components
Fuel tank inerting systems
Hydraulic systems & components
Thermal management
Wheels & brakes



Climate Control

Key Markets

Agriculture
Air conditioning
Construction Machinery
Food & beverage
Industrial machinery
Life sciences
Oil & gas
Precision cooling
Process
Refrigeration
Transportation

Key Products

Accumulators
Advanced actuators
CO₂ controls
Electronic controllers
Filter driers
Hand shut-off valves
Heat exchangers
Hose & fittings
Pressure regulating valves
Refrigerant distributors
Safety relief valves
Smart pumps
Solenoid valves
Thermostatic expansion valves



Electromechanical

Key Markets

Aerospace
Factory automation
Life science & medical
Machine tools
Packaging machinery
Paper machinery
Plastics machinery & converting
Primary metals
Semiconductor & electronics
Textile
Wire & cable

Key Products

AC/DC drives & systems
Electric actuators, gantry robots & slides
Electrohydraulic actuation systems
Electromechanical actuation systems
Human machine interface
Linear motors
Stepper motors, servo motors, drives & controls
Structural extrusions



Filtration

Key Markets

Aerospace
Food & beverage
Industrial plant & equipment
Life sciences
Marine
Mobile equipment
Oil & gas
Power generation & renewable energy
Process
Transportation
Water Purification

Key Products

Analytical gas generators
Compressed air filters & dryers
Engine air, coolant, fuel & oil filtration systems
Fluid condition monitoring systems
Hydraulic & lubrication filters
Hydrogen, nitrogen & zero air generators
Instrumentation filters
Membrane & fiber filters
Microfiltration
Sterile air filtration
Water desalination & purification filters & system



Fluid & Gas Handling

Key Markets

Aerial lift
Agriculture
Bulk chemical handling
Construction machinery
Food & beverage
Fuel & gas delivery
Industrial machinery
Life sciences
Marine
Mining
Mobile
Oil & gas
Renewable energy
Transportation

Key Products

Check valves
Connectors for low pressure fluid conveyance
Deep sea umbilicals
Diagnostic equipment
Hose couplings
Industrial hose
Mooring systems & power cables
PTFE hose & tubing
Quick couplings
Rubber & thermoplastic hose
Tube fittings & adapters
Tubing & plastic fittings



Hydraulics

Key Markets

Aerial lift
Agriculture
Alternative energy
Construction machinery
Forestry
Industrial machinery
Machine tools
Marine
Material handling
Mining
Oil & gas
Power generation
Refuse vehicles
Renewable energy
Truck hydraulics
Turf equipment

Key Products

Accumulators
Cartridge valves
Electrohydraulic actuators
Human machine interfaces
Hybrid drives
Hydraulic cylinders
Hydraulic motors & pumps
Hydraulic systems
Hydraulic valves & controls
Hydrostatic steering
Integrated hydraulic circuits
Power take-offs
Power units
Rotary actuators
Sensors



Pneumatics

Key Markets

Aerospace
Conveyor & material handling
Factory automation
Life science & medical
Machine tools
Packaging machinery
Transportation & automotive

Key Products

Air preparation
Brass fittings & valves
Manifolds
Pneumatic accessories
Pneumatic actuators & grippers
Pneumatic valves & controls
Quick disconnects
Rotary actuators
Rubber & thermoplastic hose & couplings
Structural extrusions
Thermoplastic tubing & fittings
Vacuum generators, cups & sensors



Process Control

Key Markets

Alternative fuels
Biopharmaceuticals
Chemical & refining
Food & beverage
Marine & shipbuilding
Medical & dental
Microelectronics
Nuclear Power
Offshore oil exploration
Oil & gas
Pharmaceuticals
Power generation
Pulp & paper
Steel
Water/wastewater

Key Products

Analytical Instruments
Analytical sample conditioning products & systems
Chemical injection fittings & valves
Fluoropolymer chemical delivery fittings, valves & pumps
High purity gas delivery fittings, valves, regulators & digital flow controllers
Industrial mass flow meters/ controllers
Permanent no-weld tube fittings
Precision industrial regulators & flow controllers
Process control double block & bleeds
Process control fittings, valves, regulators & manifold valves



Sealing & Shielding

Key Markets

Aerospace
Chemical processing
Consumer
Fluid power
General industrial
Information technology
Life sciences
Microelectronics
Military
Oil & gas
Power generation
Renewable energy
Telecommunications
Transportation

Key Products

Dynamic seals
Elastomeric o-rings
Electro-medical instrument design & assembly
EMI shielding
Extruded & precision-cut, fabricated elastomeric seals
High temperature metal seals
Homogeneous & inserted elastomeric shapes
Medical device fabrication & assembly
Metal & plastic retained composite seals
Shielded optical windows
Silicone tubing & extrusions
Thermal management
Vibration dampening

ENGINEERING YOUR SUCCESS.

Parker Worldwide

Europe, Middle East, Africa

AE - United Arab Emirates,
Dubai

Tel: +971 4 8127100
parker.me@parker.com

AT - Austria, Wiener Neustadt
Tel: +43 (0)2622 23501-0
parker.austria@parker.com

AT - Eastern Europe, Wiener
Neustadt
Tel: +43 (0)2622 23501 900
parker.easteurope@parker.com

AZ - Azerbaijan, Baku
Tel: +994 50 2233 458
parker.azerbaijan@parker.com

BE/LU - Belgium, Nivelles
Tel: +32 (0)67 280 900
parker.belgium@parker.com

BG - Bulgaria, Sofia
Tel: +359 2 980 1344
parker.bulgaria@parker.com

BY - Belarus, Minsk
Tel: +375 17 209 9399
parker.belarus@parker.com

CH - Switzerland, Etoy
Tel: +41 (0)21 821 87 00
parker.switzerland@parker.com

CZ - Czech Republic, Klecany
Tel: +420 284 083 111
parker.czechrepublic@parker.com

DE - Germany, Kaarst
Tel: +49 (0)2131 4016 0
parker.germany@parker.com

DK - Denmark, Ballerup
Tel: +45 43 56 04 00
parker.denmark@parker.com

ES - Spain, Madrid
Tel: +34 902 330 001
parker.spain@parker.com

FI - Finland, Vantaa
Tel: +358 (0)20 753 2500
parker.finland@parker.com

FR - France, Contamine s/Arve
Tel: +33 (0)4 50 25 80 25
parker.france@parker.com

GR - Greece, Athens
Tel: +30 210 933 6450
parker.greece@parker.com

HU - Hungary, Budaörs
Tel: +36 23 885 470
parker.hungary@parker.com

IE - Ireland, Dublin
Tel: +353 (0)1 466 6370
parker.ireland@parker.com

IT - Italy, Corsico (MI)
Tel: +39 02 45 19 21
parker.italy@parker.com

KZ - Kazakhstan, Almaty
Tel: +7 7273 561 000
parker.easteurope@parker.com

NL - The Netherlands, Oldenzaal
Tel: +31 (0)541 585 000
parker.nl@parker.com

NO - Norway, Asker
Tel: +47 66 75 34 00
parker.norway@parker.com

PL - Poland, Warsaw
Tel: +48 (0)22 573 24 00
parker.poland@parker.com

PT - Portugal, Leca da Palmeira
Tel: +351 22 999 7360
parker.portugal@parker.com

RO - Romania, Bucharest
Tel: +40 21 252 1382
parker.romania@parker.com

RU - Russia, Moscow
Tel: +7 495 645-2156
parker.russia@parker.com

SE - Sweden, Spånga
Tel: +46 (0)8 59 79 50 00
parker.sweden@parker.com

SK - Slovakia, Banská Bystrica
Tel: +421 484 162 252
parker.slovakia@parker.com

SL - Slovenia, Novo Mesto
Tel: +386 7 337 6650
parker.slovenia@parker.com

TR - Turkey, Istanbul
Tel: +90 216 4997081
parker.turkey@parker.com

UA - Ukraine, Kiev
Tel: +380 44 494 2731
parker.ukraine@parker.com

UK - United Kingdom, Warwick
Tel: +44 (0)1926 317 878
parker.uk@parker.com

ZA - South Africa, Kempton Park
Tel: +27 (0)11 961 0700
parker.southafrica@parker.com

North America

CA - Canada, Milton, Ontario
Tel: +1 905 693 3000

US - USA, Cleveland
Tel: +1 216 896 3000

Asia Pacific

AU - Australia, Castle Hill
Tel: +61 (0)2-9634 7777

CN - China, Shanghai
Tel: +86 21 2899 5000

HK - Hong Kong
Tel: +852 2428 8008

IN - India, Mumbai
Tel: +91 22 6513 7081-85

JP - Japan, Tokyo
Tel: +81 (0)3 6408 3901

KR - South Korea, Seoul
Tel: +82 2 559 0400

MY - Malaysia, Shah Alam
Tel: +60 3 7849 0800

NZ - New Zealand, Mt Wellington
Tel: +64 9 574 1744

SG - Singapore
Tel: +65 6887 6300

TH - Thailand, Bangkok
Tel: +662 186 7000

TW - Taiwan, Taipei
Tel: +886 2 2298 8987

South America

AR - Argentina, Buenos Aires
Tel: +54 3327 44 4129

BR - Brazil, Sao Jose dos Campos
Tel: +55 800 727 5374

CL - Chile, Santiago
Tel: +56 2 623 1216

MX - Mexico, Toluca
Tel: +52 72 2275 4200

© 2016 Parker Hannifin Corporation.
All rights reserved.

EMEA Product Information Centre
Free phone: 00 800 27 27 5374

(from AT, BE, CH, CZ, DE, DK, EE, ES, FI, FR, IE, IL,
IS, IT, LU, MT, NL, NO, PL, PT, RU, SE, SK, UK, ZA)

www.parker.com



Distribution Catalogue FCDE/0120/UK/V1.1 - 04/2016

Your local Parker Distributor



Ed. 2015-01-07