



aerospace
climate control
electromechanical
filtration
fluid & gas handling
hydraulics
pneumatics
process control
sealing & shielding



AC Motors

Square Frame and Round Frame
Three-Phase AC Induction Motors



PRIMERA
Technological **PRODUCT AND SERVICE** Solutions
Parker Tecnologias de Movimento,
DISTRIBUIDOR Controle e Refrigeração
Your local authorized Parker distributor
ENGINEERING YOUR SUCCESS



WARNING – USER RESPONSIBILITY

FAILURE OR IMPROPER SELECTION OR IMPROPER USE OF THE PRODUCTS DESCRIBED HEREIN OR RELATED ITEMS CAN CAUSE DEATH, PERSONAL INJURY AND PROPERTY DAMAGE.

- This document and other information from Parker-Hannifin Corporation, its subsidiaries and authorized distributors provide product or system options for further investigation by users having technical expertise.
- The user, through its own analysis and testing, is solely responsible for making the final selection of the system and components and assuring that all performance, endurance, maintenance, safety and warning requirements of the application are met. The user must analyze all aspects of the application, follow applicable industry standards, and follow the information concerning the product in the current product catalog and in any other materials provided from Parker or its subsidiaries or authorized distributors.
- To the extent that Parker or its subsidiaries or authorized distributors provide component or system options based upon data or specifications provided by the user, the user is responsible for determining that such data and specifications are suitable and sufficient for all applications and reasonably foreseeable uses of the components or systems.

Square Frame Three-Phase Induction Motors - MS Series Motor 0.75 kW - 524 kW

Overview	5
Description	5
Technical Characteristics - Overview	5
Technical Features	6
MS133 Series: 13 kW - 60 kW, 3 x 400 VAC (IP23)	6
MS160 Series: 30 kW - 114 kW, 3 x 400 VAC (IP23)	7
MS180 Series: 47 kW - 162 kW, 3 x 400 VAC (IP23)	8
MS225 - MS280 Series: 71 kW - 524 kW, 3 x 400 VAC (IP23)	9
MS100 Series: 2.5 kW - 17 kW, 3 x 400 VAC (IP54)	10
MS133 Series: 9.5 kW - 47 kW, 3 x 400 VAC (IP54)	11
MS160 Series: 19 kW - 67 kW, 3 x 400 VAC (IP54)	12
MS180 - MS225 Series: 31 kW - 202 kW, 3 x 400 VAC (IP54)	13
MS280 Series: 143 kW - 342 kW, 3 x 400 VAC (IP54)	14
Motor cooling fans	14
Dimensions	15
MS100 - MS133 - MS160 - IP54 PVAP Cooling Configuration	15
MS133 - MS160 - MS180 PVA Cooling Configuration	16
MS225 - MS280 - IP23 / IP54 PVA Cooling Configuration	17
Order Code	18
MS Series Motors	18

Round Frame Three-Phase Induction Motors - MR Series Motor 0.09 kW - 315 kW

Overview	19
Description	19
Technical Characteristics - Overview	19
Technical Features	20
MR Series: 2 Pole - 0.75 kW - 315 kW, 3 x 400 VAC	20
MR Series: 4 Pole - 0.75 kW - 315 kW, 3 x 400 VAC	21
MR Series: 6 Pole - 0.75 kW - 250 kW, 3 x 400 VAC	22
Dimensions	23
MR Series Frames MS2	23
MR Series Frames T2C	24
Auxiliary Fans	25
Order Code	26
MR Series Motors	26

Parker Hannifin

The global leader in motion and control technologies

A world class player on a local stage

Global Product Design

Parker Hannifin has more than 40 years experience in the design and manufacturing of drives, controls, motors and mechanical products. With dedicated global product development teams, Parker draws on industry-leading technological leadership and experience from engineering teams in Europe, North America and Asia.

Local Application Expertise

Parker has local engineering resources committed to adapting and applying our current products and technologies to best fit our customers' needs.

Manufacturing to Meet Our Customers' Needs

Parker is committed to meeting the increasing service demands that our customers require to succeed in the global industrial market. Parker's manufacturing teams seek continuous improvement through the implementation of lean manufacturing methods throughout the process. We measure ourselves on meeting our customers' expectations of quality and delivery, not just our own. In order to meet these expectations, Parker operates and continues to invest in our manufacturing facilities in Europe, North America and Asia.

Electromechanical Worldwide Manufacturing Locations

Europe

Littlehampton, United Kingdom
Dijon, France
Offenburg, Germany
Filderstadt, Germany
Milan, Italy

Asia

Wuxi, China
Chennai, India

North America

Rohnert Park, California
Irwin, Pennsylvania
Charlotte, North Carolina
New Ulm, Minnesota



Offenburg, Germany

Local Manufacturing and Support in Europe

Parker provides sales assistance and local technical support through a network of dedicated sales teams and authorized technical distributors throughout Europe.

For contact information, please refer to the Sales Offices on the back cover of this document or visit www.parker.com



Milan, Italy



Littlehampton, UK

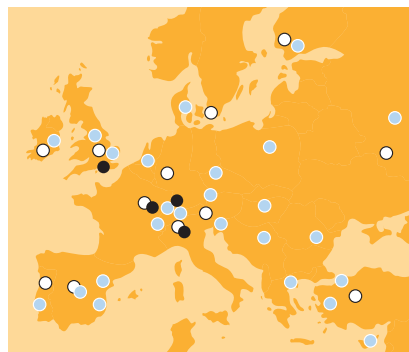

- Electromechanical Manufacturing
- Parker Sales Offices
- Distributors



Dijon, France

Square Frame Three-Phase Induction Motors - MS Series Motor 0.75 kW - 524 kW

Overview

Description

The MS series family of motors has been specially engineered to be suitable for high dynamic performance when used with a flux vector type controller - AC890 and AC690+. They permit operation in constant power at maximum speed up to 8000 min⁻¹

- **Compact square frame format**
- **Same frame dimensions as DC motors of similar power rating**
- **IP23 or IP54 protection**
- **Auxiliary cooling fan allows low-speed, high-torque operation**
- **High overload capability**
- **Higher operating speeds**
- **360 V (Contact your local sales office for details)**
- **PTC thermister (option)**
- **IP55 protection (option)**
- **Insulated bearings (option)**
- **Encoder or resolver feedback (option)**



Technical Characteristics - Overview

Motor type	Square Frame Three-Phase Induction Motor
Power range	0.75 kW ... 524 kW
Speed range	0 ... 8000 min ⁻¹
Protection level	IP23 or IP54
Feedback	Encoder or resolver (optional)
Suitable for drives	AC30V, AC690+, AC890, AC890PX-M



Technical Features

MS133 Series: 13 kW - 60 kW, 3 x 400 VAC (IP23)

Order Code	Motor	Code	Nominal speed nn [min ⁻¹]	Nominal power Pn [KW]	Nominal torque Tn [Nm]	Inertia J [kgcm ²]	Nominal voltage Vn [VRMS]	Nominal current In [ARMS]	Magnetising current Iμ [ARMS]	Nominal frequency Fn [Hz]	Max. speed at Pn Nmax1 [min ⁻¹]	Max. speed Nmax2 [min ⁻¹]	Weight W [kg]
MS24133KEC...	MS133	K EC	800	13	155	670	395	28	9	28.9	1000	7 000	132
MS24133KEB...		K EB	1000	16	153	670	395	33	10	35.7	1200	7 000	132
MS24133KE3...		K E3	1350	21	149	670	400	42	14	47.2	1500	7 000	132
MS24133KFA...		K FA	1500	23	146	670	395	45	14	52.2	1900	7 000	132
MS24133KF2...		K F2	1800	27	143	670	400	52	17	62.1	2100	7 000	132
MS24133KF3...		K F3	2000	30	142	670	400	57	19	68.7	2300	7 000	132
MS24133KG1...		K G1	2500	36	138	670	395	70	26	85.3	3700	7 000	132
MS24133KGB...		K GB	3000	42	134	670	400	79	28	101.9	3600	7 000	132
MS24133SE2...		S E2	850	19	213	860	385	40	13	30.3	1400	7 000	157
MS24133SEC...		S EC	1000	22	210	860	385	45	15	35.3	1700	7 000	157
MS24133SE3...		S E3	1250	27	206	860	400	52	18	43.5	1500	7 000	157
MS24133SFB...		S FB	1500	31	197	860	400	59	20	51.9	1700	7 000	157
MS24133SF2...		S F2	1800	35	186	860	400	67	24	61.8	2200	7 000	157
MS24133SF4...		S F4	2050	39	182	860	400	75	28	70.0	2600	7 000	157
MS24133SG1...		S G1	2450	43	168	860	400	83	31	83.3	3100	7 000	157
MS24133SGB...		S GB	3000	49	156		400	93	37	101.5	3900	7 000	157
MS24133ME4...		M E4	850	21	236	980	395	43	14	30.3	1100	7 000	175
MS24133ME3...		M E3	1000	24	229	980	390	49	17	35.2	1600	7 000	175
MS24133MEB...		M EB	1250	29	222	980	395	58	20	43.5	1800	7 000	175
MS24133MFB...		M FB	1500	34	216	980	395	67	24	51.8	2200	7 000	175
MS24133MF2...	M F2	1800	39	207	980	400	74	26	61.8	2100	7 000	175	
MS24133MF3...	M F3	2100	42	191	980	400	81	32	71.6	2700	7 000	175	
MS24133MG1...	M G1	2500	47	180	980	395	92	39	84.8	4100	7 000	175	
MS24133MG2...	M G2	2850	50	168	980	400	97	42	96.4	4000	7 000	175	
MS24133PE7...	P E7	800	23	275	1200	385	48	16	28.4	1400	7000	200	
MS24133PED...	P ED	1000	28	267	1200	390	56	20	35.0	1600	7000	200	
MS24133PFC...	P FC	1350	36	255	1200	400	69	25	46.6	1600	7000	200	
MS24133PFB...	P FB	1500	39	248	1200	390	77	31	51.5	2700	7000	200	
MS24133PF2...	P F2	1850	45	232	1200	400	86	36	63.1	2500	7000	200	
MS24133PF3...	P F3	2100	48	218	1200	400	92	37	71.4	2600	7000	200	
MS24133PG1...	P G1	2600	54	198	1200	395	105	47	87.9	4400	7000	200	
MS24133PG2...	P G2	3000	57	181	1200	400	112	56	101.1	4500	7000	200	
MS24133XE3...	X E3	850	25	281	1260	395	51	19	29.9	1200	7000	220	
MS24133XEB...	X EB	1000	29	277	1260	390	59	23	34.8	1700	7000	220	
MS24133XF3...	X F3	1250	36	275	1260	395	71	28	43.2	1900	7000	220	
MS24133XFA...	X FA	1500	42	267	1260	400	81	32	51.5	1900	7000	220	
MS24133XF1...	X F1	1800	47	249	1260	395	92	39	61.4	2900	7000	220	
MS24133XF2...	X F2	2000	50	239	1260	390	98	42	68.0	3800	7000	220	
MS24133XG1...	X G1	2600	57	209	1260	390	114	55	87.8	5600	7000	220	
MS24133XG2...	X G2	3000	60	191	1260	380	125	63	101.1	7000	7000	220	

MS160 Series: 30 kW - 114 kW, 3 x 400 VAC (IP23)

Order Code	Motor	Code	Nominal speed nn [min ⁻¹]	Nominal power Pn [KW]	Nominal torque Tn [Nm]	Inertia J [kgcm ²]	Nominal voltage Vn [VRMS]	Nominal current In [ARMS]	Magnetising current Iμ [ARMS]	Nominal frequency Fn [Hz]	Max. speed at Pn Nmax1 [min ⁻¹]	Max. speed Nmax2 [min ⁻¹]	Weight W [kg]
MS24160ME3...	MS160	M E3	650	30	441	2400	395	62	17	23.7	800	6 000	270
MS24160MEA...		M EA	900	40	424	2400	400	79	23	31.9	1000	6 000	270
MS24160ME8...		M E8	1000	44	420	2400	385	89	27	35.2	1700	6 000	270
MS24160MF4...		M F4	1300	56	411	2400	400	106	33	45.2	1600	6 000	270
MS24160MFA...		M FA	1500	63	401	2400	400	120	39	51.8	1900	6 000	270
MS24160MFE...		M FE	1800	73	387	2400	400	138	45	61.8	2300	6 000	270
MS24160MF5...		M F5	2000	80	382	2400	390	153	51	68.4	3300	6 000	270
MS24160MG2...		M G2	2600	96	353	2400	400	180	64	88.3	3600	6 000	270
MS24160LED...		L ED	650	34	500	3020	400	68	22	23.3	800	6 000	325
MS24160LEA...		L EA	850	44	494	3020	390	87	29	29.9	1400	6 000	325
MS24160LE5...		L E5	1000	51	487	3020	400	98	33	34.9	1300	6 000	325
MS24160LFB...		L FB	1300	64	470	3020	400	121	43	44.8	1800	6 000	325
MS24160LF4...		L F4	1500	71	452	3020	400	132	47	51.4	2000	6 000	325
MS24160LF3...		L F3	1850	84	434	3020	400	156	59	63.0	2700	6 000	325
MS24160LFA...		L FA	2000	88	420	3020	400	165	65	68.0	3000	6 000	325
MS24160LG1...		L G1	2450	99	386	3020	400	186	77	82.9	3800	6 000	325
MS24160PEC...		P EC	700	42	573	3600	390	85	29	24.8	1300	5 000	365
MS24160PEB...		P EB	850	50	562	3600	395	99	35	29.7	1400	5 000	365
MS24160PE4...		P E4	1000	58	554	3600	395	111	41	34.7	1700	5 000	365
MS24160PFA...		P FA	1300	73	536	3600	395	138	51	44.6	2200	5 000	365
MS24160PF1...		P F1	1500	82	522	3600	395	156	60	51.3	2700	5 000	365
MS24160PFB...		P FB	1800	94	499	3600	395	177	70	61.2	3300	5 000	365
MS24160PFC...		P FC	2000	100	477	3600	395	189	76	67.8	3800	5 000	365
MS24160PG2...		P G2	2500	110	420	3600	395	213	97	84.4	5000	5 000	365
MS24160XE3...		X E3	650	44	639	3900	385	90	30	23.1	1200	4500	395
MS24160XEB...		X EB	850	56	629	3900	390	110	28	29.7	1400	4500	395
MS24160XE1...		X E1	1000	65	621	3900	385	128	45	34.7	1900	4500	395
MS24160XF5...		X F5	1300	81	595	3900	400	151	53	44.7	1500	4500	395
MS24160XF3...		X F3	1500	91	579	3900	395	171	63	51.3	2300	4500	395
MS24160XF2...		X F2	1800	102	541	3900	390	193	75	61.2	3300	4500	395
MS24160XFC...		X FC	2000	108	516	3900	390	206	85	67.8	3900	4500	395
MS24160XG1...		X G1	2500	114	435	3900	400	208	82	84.4	3000	4500	395

MS180 Series: 47 kW - 162 kW, 3 x 400 VAC (IP23)

Order Code	Motor	Code	Nominal speed nn [min ⁻¹]	Nominal power Pn [KW]	Nominal torque Tn [Nm]	Inertia J [kgcm ²]	Nominal voltage Vn [VRMS]	Nominal current In [ARMS]	Magnetising current Iμ [ARMS]	Nominal frequency Fn [Hz]	Max. speed at Pn Nmax1 [min ⁻¹]	Max. speed Nmax2 [min ⁻¹]	Weight W [kg]
MS24180ME5...	MS180	M E5	650	47	690	5050	390	92	26	22.8	900	4 500	480
MS24180MEC...		M EC	850	61	685	5050	395	115	34	29.5	1100	4 500	480
MS24180MED...		M ED	1000	71	678	5050	395	129	39	34.4	1300	4 500	480
MS24180MEB...		M EB	1300	89	654	5050	395	158	49	44.4	1800	4 500	480
MS24180MFB...		M FB	1500	100	637	5050	395	178	58	51.0	2100	4 500	480
MS24180MF1...		M F1	1800	112	594	5050	400	198	69	60.9	2100	4 500	480
MS24180MF2...		M F2	2050	118	550	5050	385	215	67	69.3	3700	4 500	480
MS24180MG1...		M G1	2500	122	466	5050	380	225	63	84.4	4500	4 500	480
MS24180PED...		P ED	650	60	881	6300	395	117	35	23.0	800	4 500	550
MS24180PE7...		P E7	850	78	876	6300	390	147	46	29.7	1300	4 500	550
MS24180PE4...		P E4	1000	90	859	6300	390	164	49	34.7	1500	4 500	550
MS24180PE6...		P E6	1250	109	833	6300	390	200	64	42.9	2000	4 500	550
MS24180PFB...		P FB	1500	124	789	6300	385	232	77	51.2	2800	4 500	550
MS24180PFA...		P FA	1750	135	737	6300	395	242	83	59.5	2600	4 500	550
MS24180PF1...		P F1	2050	146	680	6300	390	262	85	69.5	3400	4 500	550
MS24180PG1...		P G1	2500	155	592	6300	385	285	86	84.6	4500	4 500	550
MS24180XE5...		X E5	650	65	955	7300	390	125	38	23.1	1000	4000	590
MS24180XE6...		X E6	850	84	94	7300	395	156	46	29.8	1100	4000	590
MS24180XE3...		X E3	1000	97	926	7300	395	178	51	34.8	1300	4000	590
MS24180XEA...	X EA	1300	119	874	7300	395	216	65	44.7	1700	4000	590	
MS24180XF2...	X F2	1600	138	824	7300	395	248	81	54.6	2200	4000	590	
MS24180XF1...	X F1	1800	148	785	7300	395	265	93	61.2	2700	4000	590	
MS24180XG1...	X G1	2300	162	673	7300	395	285	88	78.0	3100	4000	590	

MS225 - MS280 Series: 71 kW - 524 kW, 3 x 400 VAC (IP23)

Order Code	Motor	Code	Nominal speed nn [min ⁻¹]	Nominal power Pn [KW]	Nominal torque Tn [Nm]	Inertia J [kgcm ²]	Nominal voltage Vn [VRMS]	Nominal current In [ARMS]	Magnetising current Iμ [ARMS]	Nominal frequency Fn [Hz]	Max. speed at Pn Nmax1 [min ⁻¹]	Max. speed Nmax2 [min ⁻¹]	Weight W [kg]
MS24255SE4...	MS225	S E4	650	71	1043	10500	395	135	34	22.7	800	3 500	640
MS24255SEC...		S EC	800	86	1027	10500	395	161	42	27.6	1000	3 500	640
MS24255SE5...		S E5	1000	104	993	10500	385	200	58	34.3	1600	3 500	640
MS24255SFB...		S FB	1250	124	947	10500	390	233	65	42.6	1800	3 500	640
MS24255SFA...		S FA	1500	144	917	10500	400	260	74	50.9	1700	3 500	640
MS24255SF1...		S F1	1800	161	854	10500	390	295	80	60.9	2700	3 500	640
MS24255SF2...		S F2	2000	176	840	10500	390	320	86	67.5	2900	3 500	640
MS24255LE3...		L E3	650	95	1396	15000	395	178	46	22.7	800	3 500	860
MS24255LEA...		L EA	850	122	1370	15000	390	230	62	29.3	1300	3 500	860
MS24255LEC...		L EC	1000	141	1346	15000	395	255	70	34.3	1300	3 500	860
MS24255LE2...		L E2	1300	174	1278	15000	400	310	91	44.2	1500	3 500	860
MS24255LFA...		L FA	1450	190	1251	15000	400	336	98	49.2	1700	3 500	860
MS24255LF1...		L F1	1800	216	1146	15000	390	391	115	60.8	2800	3 500	860
MS24255XE3...		X E3	650	139	2042	21300	395	254	65	22.7	800	3500	1080
MS24255XE4...		X E4	800	169	2017	21300	385	313	82	27.7	1400	3500	1080
MS24255XEB...		X EB	1000	208	1986	21300	395	370	98	34.4	1300	3500	1080
MS24255XE1...		X E1	1250	250	1910	21300	390	447	123	42.7	2000	3500	1080
MS24255XFA...		X FA	1450	280	1844	21300	395	493	143	49.3	2100	3500	1080
MS24255XF1...		X F1	1700	305	1713	21300	390	540	163	57.6	3000	3500	1080
MS24280MEA...	MS280	M EA	690	210	2906	39330	395	370	78	23.7	900	3000	1290
MS24280ME1...		M E1	840	252	2865	39330	395	439	93	28.7	1100	3000	1290
MS24280ME2...		M E2	1060	311	2802	39330	395	536	117	36.0	1400	3000	1290
MS24280MF1...		M F1	1450	407	2680	39330	400	686	155	49.0	1500	3000	1290
MS24280LEA...		L EA	560	206	3512	47250	395	366	79	19.4	700	3000	1520
MS24280LE1...		L E1	680	247	3468	47250	395	434	95	23.3	900	3000	1520
MS24280LE2...		L E2	870	309	3391	47250	395	535	115	29.7	1100	3000	1520
MS24280LF1...		L F1	1170	401	3273	47250	395	688	156	39.7	1600	3000	1520
MS24280XEA...		X EA	470	189	3840	56820	395	347	86	16.4	600	2800	1890
MS24280XE1...		X E1	520	226	3786	56820	395	410	105	19.7	700	2800	1890
MS24280XE2...		X E2	720	281	3727	56820	395	503	132	24.7	900	2800	1890
MS24280XF1...		X F1	980	371	3615	56820	395	656	173	33.3	1300	2800	1890
MS24280XF2...		X F2	1510	524	3314	56820	400	907	262	50.9	1600	2800	1890

MS100 Series: 2.5 kW - 17 kW, 3 x 400 VAC (IP54)

Order Code	Motor	Code	Nominal speed nn [min ⁻¹]	Nominal power Pn [KW]	Nominal torque Tn [Nm]	Inertia J [kgcm ²]	Nominal voltage Vn [VRMS]	Nominal current In [ARMS]	Magnetising current Iμ [ARMS]	Nominal frequency Fn [Hz]	Max. speed at Pn Nmax1 [min ⁻¹]	Max. speed Nmax2 [min ⁻¹]	Weight W [kg]
MS54100SE2...	MS100	S E2	1000	2.5	23.9	190	395	5.9	2.5	35.8	1200	8000	50
MS54100SE1...		S E1	1200	3.0	23.8	190	395	6.9	3.1	42.4	1500	8000	50
MS54100SFA...		S FA	1500	3.7	23.6	190	380	9.0	4.2	52.3	2600	8000	50
MS54100SF1...		S F1	1750	4.3	23.5	190	395	10.0	4.7	60.7	2400	8000	50
MS54100SF2...		S F2	2000	4.9	23.4	190	380	11.8	5.5	69.0	3400	8000	50
MS54100SF3...		S F3	2400	5.7	22.7	190	395	13.3	6.5	82.2	3400	8000	50
MS54100SG2...		S G2	3000	6.8	21.6	190	390	16.3	8.3	102.2	4700	8000	50
MS54100MEA...		M EA	1000	4.1	39.2	250	395	9.4	3.9	35.6	1200	8000	65
MS54100ME2...		M E2	1200	4.9	38.8	250	400	11.0	5.1	42.1	1300	8000	65
MS54100MFB...		M FB	1500	6.0	38.2	250	385	13.7	6.1	52.1	2400	8000	65
MS54100MF1...		M F1	1750	6.9	37.7	250	400	15.2	6.8	60.5	1900	8000	65
MS54100MF3...		M F3	2100	8.1	36.8	250	400	17.8	8.4	72.0	2500	8000	65
MS54100MG1...		M G1	2700	10.0	35.4	250	400	21.9	10.6	92.0	3400	8000	65
MS54100MG2...		M G2	3000	11.0	35.0	250	400	24.2	11.2	102.1	3600	8000	65
MS54100LE2...		L E2	1000	5.7	54.4	310	400	13.0	5.8	35.4	1200	8000	80
MS54100LE1...		L E1	1250	7.0	53.5	310	400	15.7	7.1	43.7	1500	8000	80
MS54100LFC...		L FC	1500	8.2	52.2	310	390	18.4	8.3	52.0	2300	8000	80
MS54100LF1...		L F1	1800	9.6	50.9	310	400	21.0	9.6	62.0	2200	8000	80
MS54100LF2...		L F2	1900	10.0	50.3	310	395	23.5	10.8	65.4	2700	8000	80
MS54100LGA...		L GA	2400	12.2	48.5	310	400	27.0	12.8	82.0	2900	8000	80
MS54100LG1...	L G1	2700	13.3	47.0	310	395	28.8	13.8	91.9	3900	8000	80	
MS54100LG2...	L G2	3000	14.5	46.2	310	390	32.0	15.6	101.9	5000	8000	80	
MS54100PEB...	P EB	1000	6.9	66.2	370	395	15.1	6.6	35.3	1300	8000	90	
MS54100PE2...	P E2	1300	8.8	64.8	370	400	19.3	9.1	45.2	1500	8000	90	
MS54100PFB...	P FB	1500	10.0	63.7	370	380	23.0	11.5	51.8	3100	8000	90	
MS54100PF1...	P F1	1750	11.4	62.2	370	395	25.0	12.2	60.1	2600	8000	90	
MS54100PF2...	P F2	2000	12.8	61.0	370	400	28.3	13.0	68.6	2200	8000	90	
MS54100PGA...	P GA	2500	15.1	57.8	370	390	33.0	16.8	85.0	4400	8000	90	
MS54100PG2...	P G2	3000	17.0	54.1	370	400	36.8	19.1	101.6	3900	8000	90	

MS133 Series: 9.5 kW - 47 kW, 3 x 400 VAC (IP54)

Order Code	Motor	Code	Nominal speed nn [min ⁻¹]	Nominal power Pn [KW]	Nominal torque Tn [Nm]	Inertia J [kgcm ²]	Nominal voltage Vn [VRMS]	Nominal current In [ARMS]	Magnetising current I _μ [ARMS]	Nominal frequency Fn [Hz]	Max. speed at Pn Nmax1 [min ⁻¹]	Max. speed Nmax2 [min ⁻¹]	Weight W [kg]
MS54133KEC...	MS133	K EC	850	9.5	107	670	395	21	9	29.9	1400	7 000	132
MS54133KEB...		K EB	1000	11	105	670	385	24	11	34.9	2200	7 000	132
MS54133KE5...		K E5	1200	13	103	670	400	29	14	41.5	1900	7 000	132
MS54133KFA...		K FA	1500	16	102	670	390	34	15	51.6	2800	7 000	132
MS54133KF2...		K F2	1800	19	101	670	395	40	18	61.5	3100	7 000	132
MS54133KF3...		K F3	2000	21	100	670	395	43	20	68.1	3600	7 000	132
MS54133KGA...		K GA	2500	25	95	670	400	51	22	84.8	3400	7 000	132
MS54133KGB...		K GB	3000	29	92	670	395	60	29	101.4	5500	7 000	132
MS54133SE4...		S E4	850	13	146	860	390	28	12	29.8	1600	7 000	157
MS54133SEB...		S EB	1000	15	143	860	395	31	14	34.7	1700	7 000	157
MS54133SED...		S ED	1250	18	138	860	400	37	17	43.0	1700	7 000	157
MS54133SFA...		S FA	1500	21	134	860	400	42	18	51.4	1900	7 000	157
MS54133SF2...		S F2	1800	24	127	860	395	50	25	61.2	3400	7 000	157
MS54133SF4...		S F4	2100	27	123	860	390	55	26	71.2	4500	7 000	157
MS54133SG1...		S G1	2600	31	114	860	400	62	29	87.9	3700	7 000	157
MS54133SGB...		S GB	3000	34	108	860	395	71	37	101.0	6100	7 000	157
MS54133ME4...		M E4	850	15	169	980	385	33	14	29.8	1800	7 000	175
MS54133ME2...		M E2	1000	17	162	980	400	35	14	34.8	1200	7 000	175
MS54133MEB...		M EB	1300	21	156	980	400	44	21	44.6	1900	7 000	175
MS54133MFA...		M FA	1500	24	153	980	395	48	21	51.3	2500	7 000	175
MS54133MF2...	M F2	1800	27	143	980	395	56	27	61.2	3400	7 000	175	
MS54133MF3...	M F3	2100	30	136	980	390	63	31	71.2	4600	7 000	175	
MS54133MG1...	M G1	2600	34	125	980	395	71	37	87.8	5200	7 000	175	
MS54133MG2...	M G2	3000	37	118	980	400	75	39	101.0	4700	7 000	175	
MS54133PE7...	P E7	850	18	202	1200	395	39	16	29.7	1300	7 000	200	
MS54133PE3...	P E3	1000	21	201	1200	400	44	19	34.7	1300	7 000	200	
MS54133PF4...	P F4	1300	27	198	1200	400	52	23	44.6	1700	7 000	200	
MS54133PFA...	P FA	1500	30	191	1200	400	58	26	51.2	2000	7 000	200	
MS54133PF1...	P F1	1800	33	175	1200	400	65	29	61.2	2400	7 000	200	
MS54133PF3...	P F3	2100	36	164	1200	390	73	36	71.1	4600	7 000	200	
MS54133PG1...	P G1	2600	40	147	1200	385	85	46	87.6	7000	7 000	200	
MS54133PG2...	P G2	3000	43	137	1200	390	93	53	100.9	7000	7 000	200	
MS54133XE3...	X E3	850	20	225	1260	385	42	19	29.6	1900	7000	220	
MS54133XE2...	X E2	1000	23	220	1260	400	46	21	34.5	1300	7000	220	
MS54133XF3...	X F3	1300	29	213	1260	400	58	27	44.5	1800	7000	220	
MS54133XFA...	X FA	1500	33	210	1260	390	67	31	51.2	3100	7000	220	
MS54133XF1...	X F1	1800	37	196	1260	390	76	39	61.1	4100	7000	220	
MS54133XF2...	X F2	2100	40	182	1260	400	80	41	71.0	3200	7000	220	
MS54133XG1...	X G1	2600	45	165	1260	385	96	54	87.6	7000	7000	220	
MS54133XG2...	X G2	3000	47	150	1260	380	106	64	100.8	7000	7000	220	

MS160 Series: 19 kW - 67 kW, 3 x 400 VAC (IP54)

Order Code	Motor	Code	Nominal speed nn [min ⁻¹]	Nominal power Pn [KW]	Nominal torque Tn [Nm]	Inertia J [kgcm ²]	Nominal voltage Vn [Vrms]	Nominal current In [Arms]	Magnetising current Iμ [Arms]	Nominal frequency Fn [Hz]	Max. speed at Pn Nmax1 [min ⁻¹]	Max. speed Nmax2 [min ⁻¹]	Weight W [kg]
MS54160MEB...	MS160	M EB	650	19	279	2400	395	35	13	23.0	1000	6 000	255
MS54160MEC...		M EC	850	24	270	2400	400	43	17	29.6	1100	6 000	255
MS54160MEA...		M EA	1000	28	267	2400	390	51	20	34.6	1900	6 000	255
MS54160ME1...		M E1	1300	35	257	2400	400	61	24	44.6	1700	6 000	255
MS54160MFC...		M FC	1500	40	255	2400	390	72	28	51.2	2900	6 000	255
MS54160MF1...		M F1	1800	45	239	2400	400	79	33	61.2	2600	6 000	255
MS54160MFE...		M FE	2000	48	229	2400	395	86	37	67.8	3600	6 000	255
MS54160MF5...		M F5	2250	51	216	2400	390	93	42	76.1	5000	6 000	255
MS54160MGB...		M GB	2500	53	202	2400	400	93	44	84.3	4100	6 000	255
MS54160LE6...		L E6	650	22	323	3020	395	43	16	22.9	1000	6000	310
MS54160LE4...		L E4	850	28	315	3020	390	56	22	29.5	1700	6000	310
MS54160LEA...		L EA	1000	33	315	3020	400	62	23	34.5	1200	6000	310
MS54160LE3...		L E3	1300	40	294	3020	395	77	31	44.4	2300	6000	310
MS54160LFB...		L FB	1500	45	287	3020	400	84	33	51.1	2000	6000	310
MS54160LF1...		L F1	1750	50	273	3020	395	96	42	59.3	3300	6000	310
MS54160LF2...		L F2	1950	53	260	3020	400	100	42	66.0	2800	6000	310
MS54160LFA...		L FA	2250	57	242	3020	400	110	52	75.9	3700	6000	310
MS54160LG2...		L G2	2500	59	225	3020	400	114	55	84.2	4100	6000	310
MS54160PE5...		P E5	650	23	338	3600	395	47	19	22.7	1200	5 000	350
MS54160PEC...		P EC	850	30	337	3600	400	58	22	29.4	1100	5 000	350
MS54160PEA...	P EA	1000	35	334	3600	390	69	30	34.3	2300	5 000	350	
MS54160PE2...	P E2	1300	44	323	3600	400	83	36	44.3	2100	5 000	350	
MS54160PFA...	P FA	1500	49	312	3600	400	93	40	50.9	2400	5 000	350	
MS54160PF1...	P F1	1750	55	300	3600	400	104	46	59.2	2800	5 000	350	
MS54160PFB...	P FB	2000	60	286	3600	390	119	56	67.5	5000	5 000	350	
MS54160PG1...	P G1	2400	64	255	3600	385	133	70	80.7	5000	5 000	350	
MS54160XE4..	X E4	650	28	411	3900	395	56	22	22.8	1000	4500	395	
MS54160XEC..	X EC	850	36	404	3900	395	69	27	29.4	1300	4500	395	
MS54160XEA..	X EA	1000	41	392	3900	395	81	33	34.4	2300	4500	395	
MS54160XED..	X ED	1250	49	374	3900	395	94	39	42.7	2000	4500	395	
MS54160XFA..	X FA	1500	56	357	3900	385	110	49	50.9	3700	4500	395	
MS54160XF3..	X F3	1700	60	337	3900	400	114	53	57.5	2100	4500	395	
MS54160XF1..	X F1	1900	64	322	3900	400	121	56	64.2	2200	4500	395	
MS54160XFC..	X FC	2300	67	278	3900	395	133	69	77.4	4500	4500	395	

MS180 - MS225 Series: 31 kW - 202 kW, 3 x 400 VAC (IP54)

Order Code	Motor	Code	Nominal speed nn [min ⁻¹]	Nominal power Pn [KW]	Nominal torque Tn [Nm]	Inertia J [kgcm ²]	Nominal voltage Vn [VRMS]	Nominal current In [ARMS]	Magnetising current Iμ [ARMS]	Nominal frequency Fn [Hz]	Max. speed at Pn Nmax1 [min ⁻¹]	Max. speed Nmax2 [min ⁻¹]	Weight W [kg]
MS54180ME3...	MS180	M E3	650	31	455	5050	395	58	24	22.4	1000	4 500	480
MS54180MEC...		M EC	900	42	446	5050	400	78	34	30.7	1200	4 500	480
MS54180MEA...		M EA	1000	46	439	5050	395	85	36	34.1	1700	4 500	480
MS54180MEB...		M EB	1350	59	417	5050	395	108	48	45.7	2400	4 500	480
MS54180MFB...		M FB	1500	64	407	5050	385	123	58	50.7	3900	4 500	480
MS54180MFA...		M FA	1800	73	387	5050	400	129	56	60.7	2300	4 500	480
MS54180MF2...		M F2	2300	83	345	5050	395	149	60	77.4	3600	4 500	480
MS54180MG1...		M G1	2600	86	316	5050	395	157	65	87.4	4200	4 500	480
MS54180PEB...		P EB	650	38	558	6300	395	73	30	22.6	1000	4 500	550
MS54180PE5...		P E5	850	49	550	6300	400	91	37	29.3	1000	4 500	550
MS54180PE1...		P E1	1000	57	544	6300	400	107	46	34.2	1300	4 500	550
MS54180PE2...		P E2	1250	69	527	6300	400	128	56	42.5	1600	4 500	550
MS54180PEA...		P EA	1500	80	509	6300	400	149	65	50.9	2000	4 500	550
MS54180PFA...		P FA	1800	91	483	6300	395	174	82	60.8	3400	4 500	550
MS54180PF1...		P F1	2250	100	424	6300	395	183	77	75.8	3700	4 500	550
MS54180PG1...		P G1	2600	105	386	6300	390	195	86	87.5	4500	4 500	550
MS54180XEC...		X EC	650	42	617	7300	390	82	36	22.6	1300	4000	600
MS54180XE4...		X E4	850	54	607	7300	400	100	43	29.3	1100	4000	600
MS54180XE3...		X E3	1000	63	602	7300	390	121	54	34.2	2100	4000	600
MS54180XEA...		X EA	1300	78	573	7300	390	149	67	44.2	2800	4000	600
MS54180XFB...	X FB	1500	88	560	7300	400	162	72	50.9	2000	4000	600	
MS54180XF1...	X F1	1800	99	525	7300	390	192	94	60.8	4000	4000	600	
MS54180XG1...	X G1	2500	110	420	7300	400	196	82	84.2	2800	4000	600	
MS54225SSE7...	MS225	S E7	650	46	676	10500	395	87	30	22.4	900	3 500	640
MS54225SEC...		S EC	850	58	652	10500	400	109	42	29.0	1100	3 500	640
MS54225SEA...		S EA	1000	67	640	10500	400	125	46	34.0	1300	3 500	640
MS54225SFB...		S FB	1300	82	602	10500	395	157	68	43.9	2400	3 500	640
MS54225SFA...		S FA	1500	93	592	10500	390	178	75	50.6	3100	3 500	640
MS54225SF1...		S F1	1800	105	557	10500	395	200	90	60.5	3500	3 500	640
MS54225SF2...		S F2	2100	116	527	10500	400	213	87	70.5	2900	3 500	640
MS54225LE3...		L E3	650	64	940	15000	385	125	48	22.3	1400	3 500	860
MS54225LE6...		L E6	850	81	910	15000	400	150	58	29.0	1100	3 500	860
MS54225LEC...		L EC	1000	94	898	15000	385	178	71	33.9	2400	3 500	860
MS54225LE2...		L E2	1300	116	852	15000	390	219	91	43.9	2800	3 500	860
MS54225LFA...		L FA	1500	130	828	15000	400	235	95	50.6	2100	3 500	860
MS54225LF1...		L F1	1800	142	753	15000	390	273	124	60.5	3500	3 500	860
MS54225XE3...		X E3	650	92	1352	21300	385	175	67	22.4	1600	3 500	1080
MS54225XE4...		X E4	850	117	1314	21300	395	214	82	29.0	1500	3 500	1080
MS54225XEB...		X EB	1000	135	1289	21300	385	252	99	34.0	2500	3 500	1080
MS54225XE1...		X E1	1300	166	1220	21300	400	300	126	44.0	1800	3 500	1080
MS54225XFA...		X FA	1500	184	1172	21300	400	333	143	50.6	2100	3 500	1080
MS54225XF1...		X F1	1750	202	1102	21300	395	371	164	58.9	3500	3 500	1080

MS280 Series: 143 kW - 342 kW, 3 x 400 VAC (IP54)

Order Code	Motor	Code	Nominal speed nn [min ⁻¹]	Nominal power Pn [KW]	Nominal torque Tn [Nm]	Inertia J [kgcm ²]	Nominal voltage Vn [VRMS]	Nominal current In [ARMS]	Magnetising current Iμ [ARMS]	Nominal frequency Fn [Hz]	Max. speed at Pn Nmax1 [min ⁻¹]	Max. speed Nmax2 [min ⁻¹]	Weight W [kg]
MS54280MEA...	MS280	M EA	730	143	1870	39330	400	247	77	24.8	900	3 000	1290
MS54280ME1...		M E1	880	169	1834	39330	400	291	93	29.8	1100	3 000	1290
MS54280ME2...		M E2	1100	207	1797	39330	400	356	117	37.1	1400	3 000	1290
MS54280MF1...		M F1	1500	270	1719	39330	400	461	151	50.4	1900	3 000	1290
MS54280LEA...		L EA	590	140	2266	47250	400	244	79	20.1	700	3000	1520
MS54280LE1...		L E1	720	168	2228	47250	400	291	92	24.4	900	3000	1520
MS54280LE2...		L E2	900	206	2186	47250	400	356	118	30.4	1200	3000	1520
MS54280LF1...		L F1	1200	264	2101	47250	395	460	155	40.4	2100	3000	1520
MS54280XEA...		X EA	490	127	2475	56820	400	232	89	16.8	650	2800	1890
MS54280XE1...		X E1	600	153	2435	56820	400	277	104	20.4	750	2800	1890
MS54280XE2...		X E2	760	191	2400	56820	400	342	129	25.8	1000	2800	1890
MS54280XF1...		X F1	1020	248	2322	56820	400	444	173	34.4	1400	2800	1890
MS54280XF2...		X F2	1540	342	2121	56820	400	617	262	51.7	2200	2800	1890

Motor cooling fans

Motor	Cooling method	Voltage [V rms]	Current [Arms]	Noise [dB]	Voltage [Vrms]	Current [Arms]	Noise [dB]	Air flow [m ³ /h]	Pressure [mmH ₂ O]
		Frequency 50 Hz			Frequency 60 Hz				
MS 100	IP54-PVAP	345-440	0.19	66	345-460	0.12	70	220	12
MS 133	IP54-PVAP	345-480	0.34	74	345-480	0.31	78	720	17
MS 133	IP23-PVA	315-500	1.1	75	380-600	1.1	79	930	93
MS 160	IP54-PVAP	380-400	0.44	78	380-440	0.5	80	1100	21
MS 160	IP23-PVA	300-460	2.6	78	360-510	2.38	82	1300	125
MS 180	IP54/IP23-PVA	315-400	4.8	80	380-480	4.51	84	2200	120
MS 225	IP54/IP23-PVA	380-400	6.3	86	460-480	6.0	86	3300	315
MS 280	IP54/IP23-PVA	380-400	6.5	86	460-480	6.5	86	3900	285

Dimensions

MS100 - MS133 - MS160 - IP54 PVAP Cooling Configuration

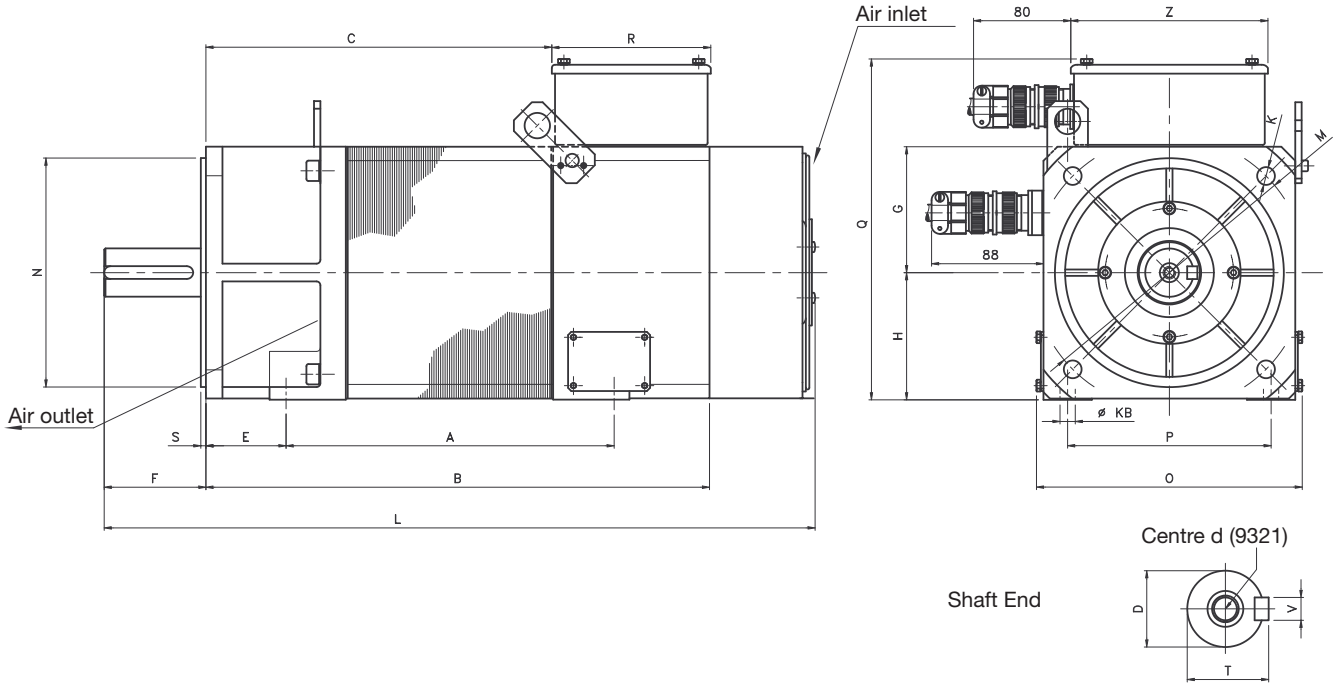

Motor		A	E	S	F	B	L	KB	P	O	M	K	H	G	Q	N	C	R	Z	D	T	V	d
MS100	S	198	63	4	80	336	500	12	160	209	215	14	100	99	268	180	212	125	155	38	41	10	M12
	M	258	63	4	80	396	560	12	160	209	215	14	100	99	268	180	272	125	155	38	41	10	M12
	L	318	63	4	80	456	620	12	160	209	215	14	100	99	268	180	332	125	155	38	41	10	M12
	P	378	63	4	80	516	680	12	160	209	215	14	100	99	268	180	392	125	155	38	41	10	M12
MS133	K	308	66	5	110	478	690	13	216	271	300	18	132	130	345	250	310	170	245	48	51.5	14	M16
	S	368	66	5	110	538	750	13	216	271	300	18	132	130	345	250	370	170	245	48	51.5	14	M16
	M	408	66	5	110	578	790	13	216	271	300	18	132	130	345	250	410	170	245	48	51.5	14	M16
	P	473	66	5	110	643	855	13	216	271	300	18	132	130	345	250	475	170	245	48	51.5	14	M16
MS160	M	402	108	5	110	642	872	14	254	327	350	18	160	158	400	300	473	170	245	55	59	16	M20
	L	482	108	5	110	722	952	14	254	327	350	18	160	158	400	300	553	170	245	55	59	16	M20
	P	552	108	5	110	792	1022	14	254	327	350	18	160	158	400	300	623	170	245	55	59	16	M20

MS133 - MS160 - MS180 PVA Cooling Configuration

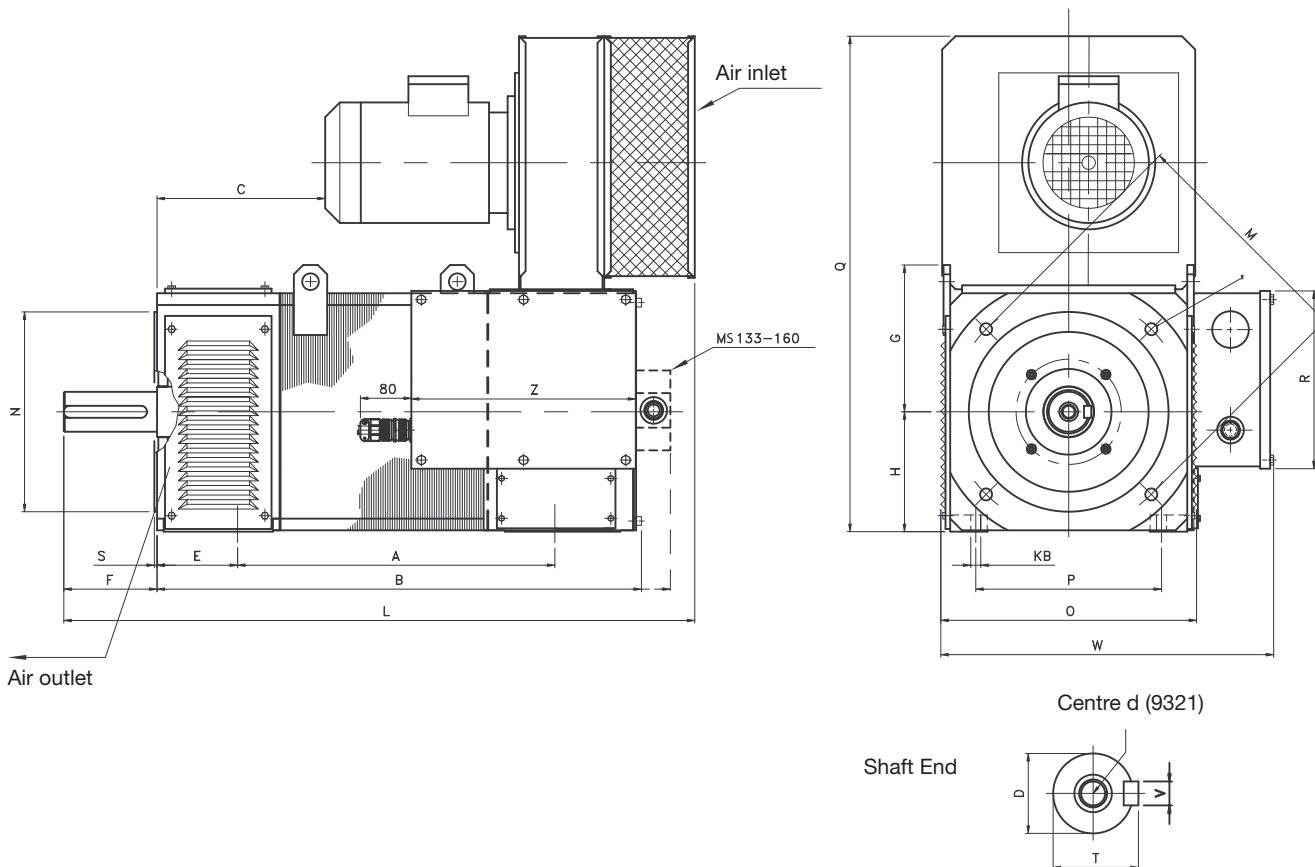

MS133 - MS160 - IP23 PVA Cooling Configuration

Motor		A	E	S	F	B	L	KB	P	O	M	K	H	G	Q	N	C	W	R	Z	D	T	V	d
MS133	K	308	66	5	110	508	646	13	216	294	300	18	132	182	523	250	101	367	170	245	48	51.5	14	M16
	S	368	66	5	110	568	706	13	216	294	300	18	132	182	523	250	161	367	170	245	48	51.5	14	M16
	M	408	66	5	110	608	746	13	216	294	300	18	132	182	523	250	201	367	170	245	48	51.5	14	M16
	P	473	66	5	110	673	811	13	216	294	300	18	132	182	523	250	266	367	170	245	48	51.5	14	M16
MS160	M	402	108	5	110	675	835	14	254	350	350	18	160	206	637	300	228	423	170	245	55	59	16	M20
	L	482	108	5	110	755	915	14	254	350	350	18	160	206	637	300	308	423	170	245	55	59	16	M20
	P	552	108	5	110	825	985	14	254	350	350	18	160	206	637	300	378	423	170	245	55	59	16	M20

MS180 IP23 & IP54 PVA Cooling Configuration

Motor		A	E	S	F	B	L	KB	P	O	M	K	H	G	Q	N	C	W	R	Z	D	T	V	d
MS180	M	567	121	5	140	816	1039	15	279	394	350	18	180	215	740	300	344	505	267	337	60	64	18	M20
	P	667	121	5	140	916	1139	15	279	394	350	18	180	215	740	300	444	505	267	337	60	64	18	M20

MS225 - MS280 - IP23 / IP54 PVA Cooling Configuration

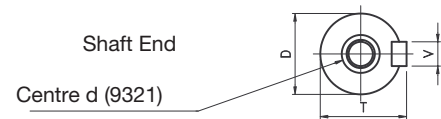
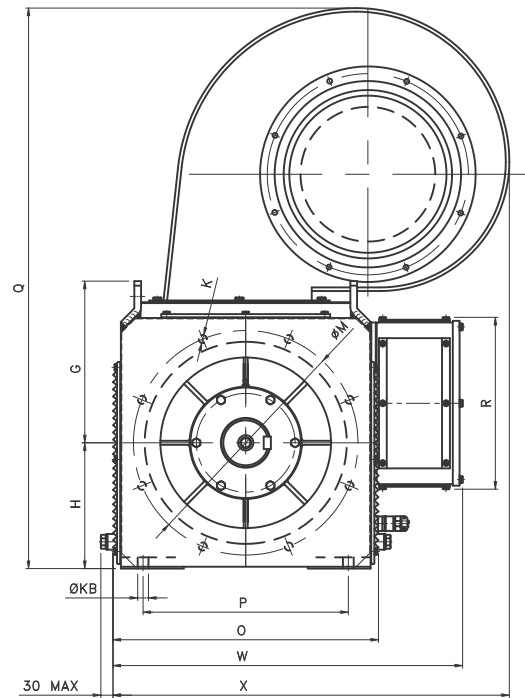
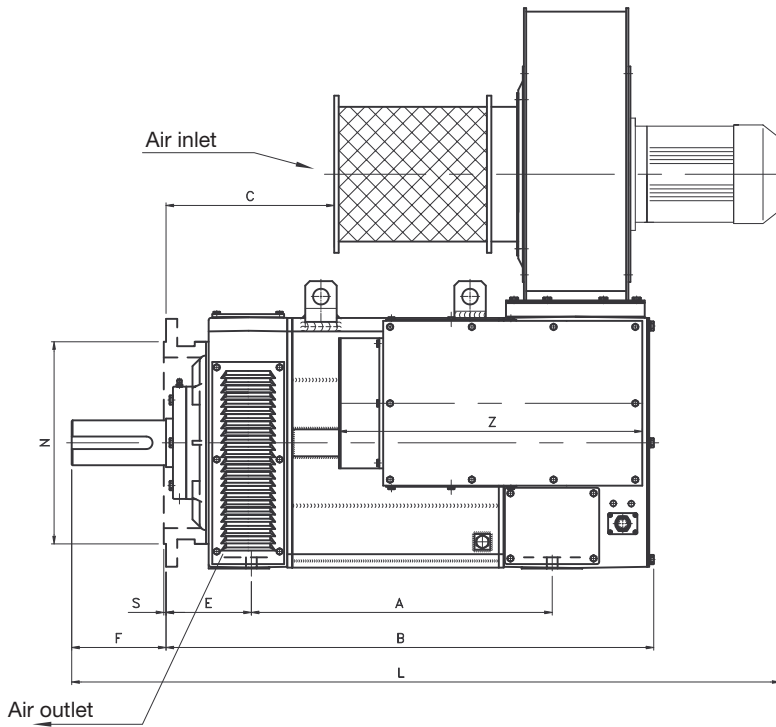

Motor	A	E	S	F	B	L	KB	P	O	M	K	H	G	Q	N	C	W	X	R	Z	D	T	V	d	
MS225	S	475	149	5	140	791	1203	19	356	482	400	18	225	272	1061	350	255	602	697	267	337	75	79.5	20	M20
	L	615	149	5	140	931	1343	19	356	482	400	18	225	272	1061	350	395	602	697	267	337	75	79.5	20	M20
	X	805	149	5	140	1121	1533	19	356	482	400	18	225	272	1061	350	585	602	697	267	337	75	79.5	20	M20
MS280	M	670	190	5	210	1086	1577	24	457	592	500	18	280	360	1248	450	375	780	882	383	676	100	106	28	M24
	L	770	190	5	210	1186	1677	24	457	592	500	18	280	360	1248	450	475	780	882	383	676	100	106	28	M24
	X	930	190	5	210	1346	1837	24	457	592	500	18	280	360	1248	450	635	780	882	383	676	100	106	28	M24

Order Code

MS Series Motors

	1	2	3	4	5	6	7	8	9	10	11
Order example	MS	23	100S	E1	1	B	R0	0	K	1	0000

1	Type of Motor
MS	Square Frame Motor

2	IP Rating / Voltage
23	IP23 / 360V
24	IP23 / 460V
53	IP54 / 360V
54	IP54 / 460V

3	Motor Frame Size
100S	Frame 100S
100M	Frame 100M
100L	Frame 100L
100P	Frame 100P
133S	Frame 133S
133M	Frame 133M
133P	Frame 133P
133K	Frame 133K
133X	Frame 133X
160M	Frame 160M
160L	Frame 160L
160P	Frame 160P
160X	Frame 160X
180M	Frame 180M
180P	Frame 180P
180X	Frame 180X
225S	Frame 225S
225L	Frame 225L
225X	Frame 225X
280M	Frame 280M
280L	Frame 280L
280X	Frame 280X

4	Windings/Speed
E1	
E2	
E3	
E4	
E5	Refer to motor technical features to identify the required frame size and winding combination to suit your requirements
E6	
E7	
E8	
EA	
EB	
EC	
ED	

4	Windings/Speed (continued)
F1	
F2	
F3	
F5	
FA	Refer to motor technical features to identify the required frame size and winding combination to suit your requirements
FB	
FC	
FE	
G1	
G2	
GA	
GB	

5	Mounting
1	Foot Mounting (B3)
2	Flange Mounting (B5)
3	Foot & Flange Mounting (B35)

6	Brake
0	Not Fitted
B	Brake Fitted

7	Bearings/Rollers
R0	Standard Roller Bearings
RI	Insulated Roller Bearings
BI	Insulated Ball Bearings

8	Motor Shaft
0	Straight Shaft without Keyway
1	Straight Shaft with Keyway

9	Thermal Protection
K	Klixon Protection
T	Thermistor Protection
P	PT100

10	Feedback Device
0	None
1	1024 PPR Encoder
2	2048 PPR Encoder
3	Resolver (45 kHz)

11	Special Options
0000	None

Round Frame Three-Phase Induction Motors - MR Series Motor 0.09 kW - 315 kW

Overview

Description

These IE2 efficiency round frame three-phase induction motors are suitable for use with the entire range of Parker variable speed AC drives. Featuring a durable rigid construction, these motors are specially engineered for use in heavy industrial applications. Featuring axial, In-Line force ventilation fan and optional 2048 ppr encoder, the round frame MR Series motor is suitable for general purpose open or closed-loop control applications. For higher dynamic performance, such as that required in printing or test rig applications, the MS series square frame vector motor should be considered.

- **Light aluminium body up to and including 160 frame size. Cast iron construction over 160 frame**
- **IP55 Protection as minimum**
- **Foot, flange, or foot and flange mounting options**
- **Insulation Class F (IEC - EN60034 -1)**
- **Auxiliary cooling fan allowing low-speed operation**
- **3x PTC thermistors embedded in motor stator as standard**
- **Holding brake or brake with hand release (Option)**
- **2048 ppr encoder (Option)**
- **2,4, or 6 poles (Option)**



Technical Characteristics - Overview

Motor type	Round Frame Three-Phase Induction Motor
Power range	0.09 kW ... 315 kW
Speed range	0 – 3000 min ⁻¹
Protection level	IP55
Insulation Class	F (IEC – EN600034 -1)
Feedback	Encoder (optional)
Suitable for drives	AC30V, AC690+, AC890, AC890PX-M

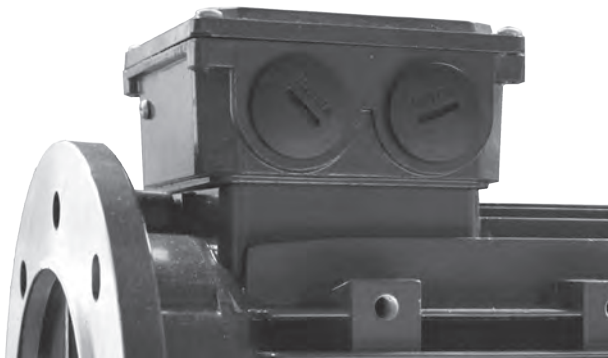

Generous motor terminal box for easy access



Simplified connection with a pre-wired encoder plug

Technical Features

MR Series: 2 Pole - 0.75 kW - 315 kW, 3 x 400 VAC

Order Code	Nominal Power P _n [kW]	Frame Size	Nominal speed n _n [min ⁻¹]	Full-load current at 400 V [Arms]	Efficiency [%]	Power factor [cosφ]	Torque C _n [Nm]	Is/In	Cs/Cn
MR2P00018...	0.18	TECA 563-2	2710	0.55	63	0.75	-	6	-
MR2P00025...	0.25	TECA 632-2	2710	0.71	65	0.78	-	6	-
MR2P00037...	0.37	TECA 633-2	2710	1.05	65	0.78	-	6	-
MR2P00055...	0.55	TECA 712-2	2760	1.42	71	0.79	-	6	-
MR2P00075...	0.75	MS2 801-2	2840	1.75	77.4	0.80	2.49	5.8	2.9
MR2P00110...	1.1	MS2 802-2	2850	2.42	80	0.82	3.53	6.8	3.5
MR2P00150...	1.5	MS2 90S-2	2850	3.20	81.4	0.83	5.09	6.9	3.5
MR2P00220...	2.2	MS290L-2	2860	4.54	83.2	0.84	7.32	7.9	4.1
MR2P00300...	3	MS2 100L-2	2880	5.88	84.6	0.87	9.96	7.8	3.4
MR2P00400...	4	MS2 112M-2	2890	7.54	86	0.89	13.16	7.5	2.7
MR2P00550...	5.5	MS2 132S1-2	2900	10.2	87.2	0.89	18.25	7.7	2.4
MR2P00750...	7.5	MS2 132S2-2	2910	13.8	88.1	0.89	24.47	8.4	2.6
MR2P01100...	11	MS2 160M1-2	2930	19.9	89.4	0.89	20.23	7.6	2.4
MR2P01500...	15	MS2 160M2-2	2930	26.9	90.3	0.89	27.68	8	2.6
MR2P01850...	18.5	MS2 160L-2	2940	32.6	90.9	0.90	33.42	9	3
MR2P02200...	22	T2C 180M-2	2930	39.08	91.3	0.89	71.70	7.5	2.3
MR2P03000...	30	T2C 200L1-2	2925	53.49	92	0.88	97.94	6.7	2.4
MR2P03700...	37	T2C 200L2-2	2930	64.15	92.5	0.90	120.59	6.3	2.3
MR2P04500...	45	T2C 225M-2	2930	79.45	92.9	0.88	146.66	6.9	2.3
MR2P05500...	55	T2C 250M-2	2940	96.80	93.2	0.88	178.64	8	2.3
MR2P07500...	75	T2C 280S-2	2940	125.45	93.8	0.92	243.60	8	2.2
MR2P09000...	90	T2C 280M-2	2940	150.06	94.1	0.92	292.33	7.7	2.2
MR2P11000...	110	T2C 315S-2	2940	187.08	94.3	0.90	357.29	7.7	2
MR2P13200...	132	T2C 315M-2	2940	221.33	94.6	0.91	428.74	7.6	2
MR2P16000...	160	T2C 315L1-2	2945	270.68	94.8	0.90	518.81	7.8	2
MR2P20000...	200	T2C 315L2-2	2945	341.44	95	0.89	648.51	7.9	2
MR2P25000...	250	T2C 355M-2	2945	422.05	95	0.90	810.64	7.8	2
MR2P31500...	315	T2C355L-2	2945	537.76	95	0.89	1021.40	7.8	2

Motors below 0.75 kW are not IE rated. For dimensions please contact your local sales office.

MR Series: 4 Pole - 0.75 kW - 315 kW, 3 x 400 VAC

Order Code	Nominal Power P _n [kW]	Frame Size	Nominal speed n _n [min ⁻¹]	Full-load current at 400 V [Arms]	Efficiency [%]	Power factor [cosφ]	Torque C _n [Nm]	Is/In	Cs/Cn
MR4P00012...	0.12	TECA 631-4	1360	0.55	52	0.64	-	4	-
MR4P00018...	0.18	TECA 632-4	1310	0.7	57	0.65	-	4	-
MR4P00025...	0.25	TECA 633-4	1340	0.91	60	0.66	-	4	-
MR4P00037...	0.37	TECA 712-4	1370	1.11	65	0.74	-	6	-
MR4P00055...	0.55	TECA 713-4	1380	1.6	66	0.75	-	6	-
MR4P00075...	0.75	MS2 802-4	1410	1.79	79.6	0.76	5.27	5.3	2.8
MR4P00110...	1.1	MS2 90S-4	1420	2.50	81.4	0.78	7.61	6.7	3.8
MR4P00150...	1.5	MS2 90L-4	1420	3.31	82.8	0.79	10.39	7.2	4
MR4P00220...	2.2	MS2 100L1-4	1440	4.83	84.3	0.78	14.76	7.4	3.6
MR4P00300...	3	MS2 100L2-4	1440	6.33	85.5	0.80	20.13	7.8	3.8
MR4P00400...	4	MS2 112M-4	1440	8.23	86.6	0.81	26.89	7.1	3.1
MR4P00550...	5.5	MS2 132S-4	1450	10.9	87.9	0.83	36.25	7.4	2.6
MR4P00750...	7.5	MS2 132M-4	1450	14.5	88.7	0.84	49.21	7.7	2.8
MR4P01100...	11	MS2 160M-4	1450	21.6	89.8	0.82	71.86	7.7	2.7
MR4P01500...	15	MS2 160L-4	1450	28.4	90.6	0.84	97.90	7.3	2.4
MR4P01850...	18.5	MS2 180M-4	1460	34.4	91.4	0.85	121.32	7.4	2.2
MR4P02200...	22	T2C 180L-4	1460	38.95	91.6	0.89	143.89	7.5	2.3
MR4P03000...	30	T2C 200L-4	1460	53.31	92.3	0.88	196.22	7.9	2.4
MR4P03700...	37	T2C 225S-4	1470	72.02	92.7	0.80	240.36	6.7	2.4
MR4P04500...	45	T2C 225M-4	1480	87.21	93.1	0.80	290.35	7	2.3
MR4P05500...	55	T2C 250M-4	1480	96.49	93.5	0.88	354.87	7.4	2.4
MR4P07500...	75	T2C 280S-4	1480	126.56	94.0	0.91	483.92	7.5	2.2
MR4P09000...	90	T2C 280M-4	1480	149.90	94.2	0.92	580.70	7.7	2.25
MR4P11000...	110	T2C 315S-4	1480	186.69	94.5	0.90	709.75	7.8	2
MR4P13200...	132	T2C 315M-4	1480	221.09	94.7	0.91	851.69	7.8	2
MR4P16000...	160	T2C 315L1-4	1480	267.43	94.9	0.91	1032.36	7.9	2
MR4P20000...	200	T2C 315L2-4	1480	337.29	95.1	0.90	1290.45	7.7	2
MR4P25000...	250	T2C 355M-4	1480	426.35	95.1	0.89	1613.06	7.9	2
MR4P31500...	315	T2C355L-4	1480	531.23	95.1	0.90	2032.45	7.8	2

Motors below 0.75 kW are not IE rated. For dimensions please contact your local sales office.

MR Series: 6 Pole - 0.75 kW - 250 kW, 3 x 400 VAC

Order Code	Nominal Power Pn [kW]	Frame Size	Nominal speed nn [min ⁻¹]	Full-load current at 400 V [Arms]	Efficiency [%]	Power factor [cosφ]	Torque Cn [Nm]	Is/In	Cs/Cn
MR6P00009...	0.09	TECA 631-6	840	0.51	42	0.61	-	3.5	
MR4P00012...	0.12	TECA 632-6	850	0.62	45	0.62	-	3.5	-
MR4P00018...	0.18	TECA 711-6	880	0.70	56	0.66	-	4	-
MR4P00025...	0.25	TECA 712-6	900	0.87	59	0.7	-	4	-
MR4P00037...	0.37	TECA 713-6	890	1.27	61	0.69	-	6	-
MR4P00055...	0.55	TECA 802-6	900	1.65	67	0.72	-	6	-
MR6P00075...	0.75	MS2 90S-6	925	2.01	76.0	0.71	7.75	4.7	3.1
MR6P00110...	1.1	MS2 90L-6	930	2.82	78.1	0.72	11.43	5	3.2
MR6P00150...	1.5	MS2 100L-6	940	3.71	80.0	0.73	15.09	5.9	3.1
MR6P00220...	2.2	MS2 112M-6	945	5.17	81.8	0.75	22.13	5.5	2.6
MR6P00300...	3	MS2 132S-6	960	6.84	83.3	0.76	30.32	5.7	2.2
MR6P00400...	4	MS2 132M1-6	960	8.86	84.6	0.77	41.25	6.2	2.4
MR6P00550...	5.5	MS2 132M2-6	960	12.0	86	0.77	54.86	6.7	2.6
MR6P00750...	7.5	MS2 160M-6	970	16.1	87.5	0.77	74.69	5.6	2
MR6P01100...	11	MS2 160L-6	970	22.9	89.0	0.78	108.92	5.8	2
MR6P01500...	15	MS2 180L-6	975	28.9	90.1	0.83	147.77	7.5	1.9
MR6P01850...	18.5	MS2 200L1-6	975	35.6	90.4	0.83	180.32	6.3	2.2
MR6P02200...	22	T2C 200L2-6	965	40.62	90.9	0.86	217.70	7.9	2.3
MR6P03000...	30	T2C 225M-6	975	55.56	91.7	0.85	293.82	7.9	2.2
MR6P03700...	37	T2C 250M-6	975	69.79	92.2	0.83	362.38	7.5	2.3
MR6P04500...	45	T2C 280S-6	980	81.48	92.7	0.86	438.49	7.2	2.3
MR6P05500...	55	T2C280M1-6	980	99.15	93.1	0.86	535.93	7.7	2.2
MR6P07500...	75	T2C 315S-6	980	129.81	93.7	0.89	730.81	7.9	2.1
MR6P09000...	90	T2C 315M-6	980	153.56	94	0.90	876.98	7.9	2
MR6P11000...	110	T2C 315L1-6	980	187.08	94.3	0.90	1071.86	7.7	2
MR6P13200...	132	T2C 315L2-6	980	226.30	94.6	0.89	1286.23	7.8	2
MR6P16000...	160	T2C 355M1-6	980	267.71	94.8	0.91	1559.07	7.8	2
MR6P20000...	200	T2C 355M2-6	980	337.64	95	0.90	1948.84	7.8	2
MR6P25000...	250	T2C 355L-6	980	426.79	95	0.89	2436.06	7.8	2

Motors below 0.75 kW are not IE rated. For dimensions please contact your local sales office.

Dimensions

MR Series Frames MS2

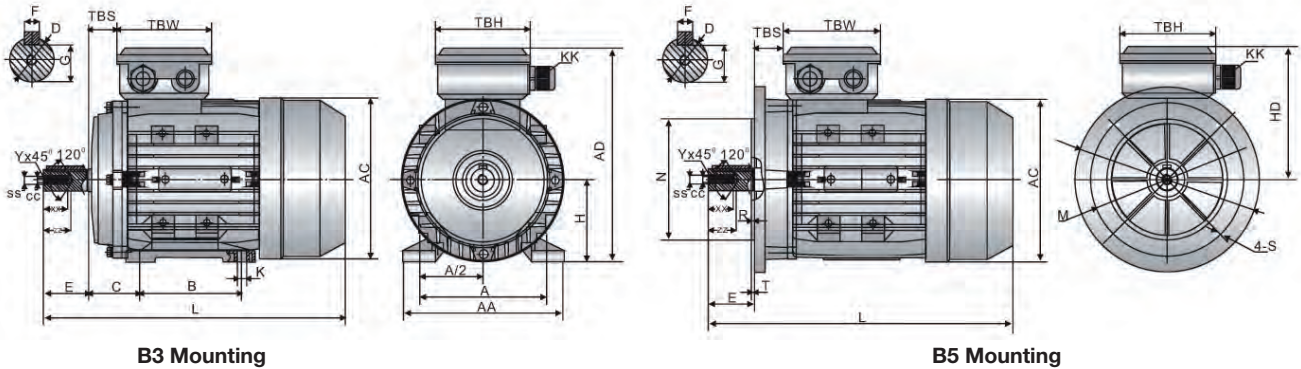

Frame MS2	B3 Foot Mounting					Shaft							General								
	H	A	B	C	K	D	E	F	G	SS	XX	ZZ	AA	AD	HD	AC	L	KK	TBS	TBW	TBH
56	56	90	71	36	5.8x8.8	ø9	20	3	7.2	M3	9	12	110	156	100	ø117	196	1-M16x1.5	14	88	88
63	63	100	80	40	7x10	ø11	23	4	8.5	M4	10	14	120	171	108	ø130	220	1-M16x1.5	14	94	94
71	71	112	90	45	7x10	ø14	30	5	11	M5	12	17	132	186	115	ø147	241	1-M20x1.5	20	94	94
80	80	125	100	50	10x13	ø19	40	6	15.5	M6	16	21	160	213	133	ø163	290	1-M20x1.5	27	105	105
90S	90	140	100	56	10x13	ø24	50	8	20	M8	19	25	175	229	139	ø183	312	1-M20x1.5	30	105	105
90L1/L2	90	140	125	56	10x13	ø24	50	8	20	M8	19	25	175	229	139	ø183	337/367	1-M20x1.5	30	105	105
100	100	160	140	63	12x15	ø28	60	8	24	M10	22	30	198	252	152	ø205	369	2-M20x1.5	26	105	105
112	112	190	140	70	12x15	ø28	60	8	24	M10	22	30	220	279	167	ø229	395	2-M25x1.5	32	112	112
132S	132	216	140	89	12x15	ø38	80	10	33	M12	28	37	252	318	186	ø265	437	2-M25x1.5	38	112	112
132M/L	132	216	178	89	12x15	ø38	80	10	33	M12	28	37	252	318	186	ø265	475/501	2-M25x1.5	38	112	112
160M/L	160	254	210/254	108	15x19	ø42	110	12	37	M16	36	45	290	384	224	ø325	640	2-M32x1.5	64	143	143
180M/L	180	279	241/279	121	15x25	ø48	110	14	42.5	M18	36	45	340	440	260	ø368	730	2-M32x1.5	73	190	190
200L	200	318	305	133	19x29	ø55	110	16	49	M20	42	53	390	460	260	ø368	745	2-M32x1.5	85	190	190

Frame MS2	B5 Flange Mounting					
	M	N	P	T	S	R
56	ø100	ø80	ø120	3.0	ø7	0
63	ø115	ø95	ø140	3.0	ø10	0
71	ø130	ø110	ø160	3.5	ø10	0
80	ø165	ø130	ø200	3.5	ø12	0
90S	ø165	ø130	ø200	3.5	ø12	0
90L1/L2	ø165	ø130	ø200	3.5	ø12	0
100	ø215	ø180	ø250	4.0	ø15	0
112	ø215	ø180	ø250	4.0	ø15	0
132S	ø265	ø230	ø300	4.0	ø15	0
132M/L	ø265	ø230	ø300	4.0	ø15	0
160M/L	ø300	ø250	ø350	5.0	ø19	0
180M/L	ø300	ø250	ø350	5.0	ø19	0
200L	ø350	ø300	ø400	5.0	ø19	0

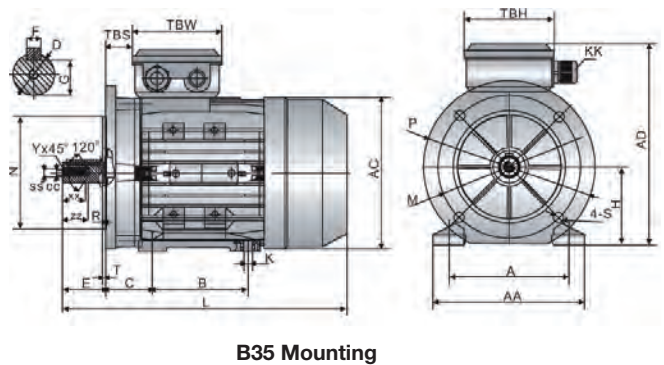

For Dimensions of Motors below 0.75 kW please contact your local sales office.

MR Series Frames T2C

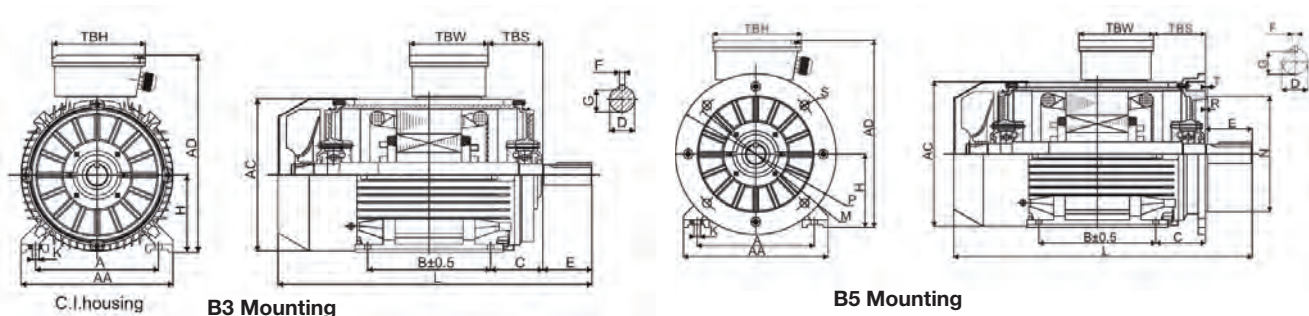

Frame T2C	B3 Foot Mounting				Shaft					General							
	H	A	B	C	D	E	F	G	K	AA	AD	HD	AC	L	TBS	TBW	TBH
180M/L	180	279	241/279	121	ø48	110	14	42.5	ø15	348	439	259	360	687/725	160/180	162	187
200L	200	318	305	133	ø55	110	16	49	ø19	388	497	297	399	768	192	186	233
225S	225	356	286	149	ø60	140	18	53	ø19	436	553	328	465	814	190	186	233
225M	2 Pole	225	356	311	ø55	110	16	49	ø19	436	553	328	456	809	202	186	233
	4,6 Pole	225	356	311	ø60	140	18	53	ø19	436	553	328	465	839	202	186	233
250M	2 Pole	250	406	349	ø60	140	18	53	ø24	484	616	366	506	918	233	218	260
	4,6 Pole	250	406	349	ø65	140	18	58	ø24	484	616	366	506	918	233	218	260
280S/M	2 Pole	280	457	368/419	ø65	140	18	58	ø24	557	668	388	559	984/1035	265	218	260
	4,6 Pole	280	457	368/419	ø75	140	20	67.5	ø24	557	668	388	559	984/1035	265	218	260
315S	2 Pole	315	457	406	ø65	140	18	58	ø28	630	845	530	680	1205	130	280	320
	4,6 Pole	315	508	406	ø80	170	22	71	ø28	630	845	530	680	1235	130	280	320
315M/L	2 Pole	315	508	457/508	ø65	140	18	58	ø28	630	845	530	680	1355	130	280	320
	4,6 Pole	315	508	457/508	ø80	170	22	71	ø28	630	845	530	680	1385	130	280	320
355M/L	2 Pole	355	610	560/630	ø75	140	20	67.5	ø28	740	1010	655	820	1500	HO	330	380
	4,6 Pole	355	610	560/630	ø100	210	28	90	ø28	740	1010	655	820	1570	140	330	380

Frame T2C	B5 Flange Mounting						
	N	M	P	S	T	R	
180M/L	250	300	350	4-ø19	5	0	
200L	300	350	400	4-ø19	5	0	
225S	350	400	450	8-ø19	5	0	
225M	2 Pole	350	400	450	8-ø19	5	0
	4,6 Pole	350	400	450	8-ø19	5	0
250M	2 Pole	450	500	550	8-ø19	5	0
	4,6 Pole	450	500	550	8-ø19	5	0
280S/M	2 Pole	450	500	550	8-ø19	5	0
	4,6 Pole	450	500	550	8-ø19	5	0
355M/L	2 Pole	550	600	660	8-ø24	6	0

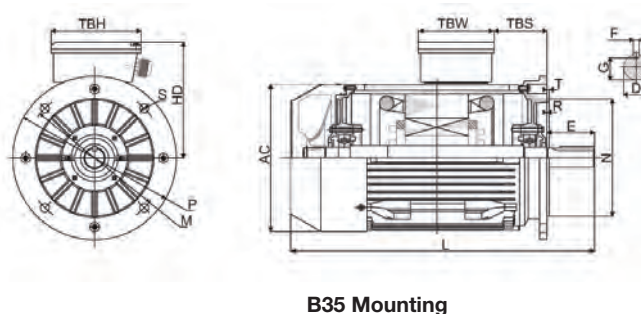

For Dimensions of Motors below 0.75 kW please contact your local sales office.

Auxiliary Fans

All frame sizes can be supplied with cooling system IC416 (forced ventilation). In this case a suitable fan is fitted inside the fan cover and suitably reinforced. We always recommend forced ventilation on motors used below 25 Hz or above 75 Hz. Consequently the ventilation is independant of the rotation speed of the motor itself.

Frame Size	Three Phase Supply Voltage [VAC]	Supply Frequency [Hz]	Input Power [W]	Single Phase Supply Voltage [VAC]	Supply Frequency [Hz]	Input Power [W]	Overall length L (increasing) [mm]
63	230/400	50	20	230	50	17	92
71	230/400	50	25	230	50	33	92
80	230/400	50	29	230	50	35	98
90	230/400	50	32	230	50	45	97
100	230/400	50	58	230	50	30	103
112	230/400	50	69	230	50	35	93
132	230/400	50	52	230	50	32	109
160	230/400	50	70	230	50	50	145
180	230/400	50	85	230	50	47	130
200	230/400	50	105	230	50	49	140
225	230/400	50	105	230	50	70	160
250	230/400	50	115	230	50	126	167
280	230/400	50	180	230	50	149	175
315	230/400	50	480	230	50	-	205
355	230/400	50	400	230	50	-	205

When an encoder is mounted with the ventilation option, dimension L does not change and remains the same as the motor with independant ventilation.

Order Code

MR Series Motors

	1	2	3	4	5	6	7	8	9	10	11
Order example	MR	2P	00018	1	B	R	1	T	1	1	0000

1	Type Of Motor (mandatory field)
MR	Round Frame Motor
2	Motor Type
2P	2 Pole
4P	4 Pole
6P	6 Pole
3	Motor Rating
00009	0.09 kW (6 Pole only)
00012	0.12 kW (not available as 2 Pole)
00018	0.18 kW
00025	0.25 kW
00037	0.37 kW
00055	0.55 kW
00075	0.75 kW
00110	1.1 kW
00150	1.5 kW
00220	2.2 kW
00300	3 kW
00400	4 kW
00550	5.5 kW
00750	7.5 kW
01100	11 kW
01500	15 kW
01850	18.5 kW
02200	22 kW
03000	30 kW
03700	37 kW
04500	45 kW
05500	55 kW
07500	75 kW
09000	90 kW
11000	110 kW
13200	132 kW
16000	160 kW
20000	200 kW
22000	220 kW
25000	250 kW
28000	280 kW (not available as 6 Pole)
31500	315 kW (not available as 6 Pole)

4	Mounting
1	Foot Mounting (B3)
2	Flange Mounting (B5)
3	Floot & Flange Mounting (B35)
5	Brake
0	Not Fitted
B	Brake Fitted
H	Hand Brake Fitted
6	Bearings/Rollers
B	Bearings
R	Rollers
7	Force Ventilation Fan
0	None
1	Single Phase
2	Three Phase
8	Protection (mandatory field)
T	Thermistors
9	Feedback Device
0	None
1	2048 ppr Encoder
10	IP Rating (mandatory field)
1	IP55
11	Special Options
0000	None



Parker's Motion & Control Technologies

At Parker, we're guided by a relentless drive to help our customers become more productive and achieve higher levels of profitability by engineering the best systems for their requirements. It means looking at customer applications from many angles to find new ways to create value. Whatever the motion and control technology need, Parker has the experience, breadth of product and global reach to consistently deliver. No company knows more about motion and control technology than Parker. For further info call 00800 27 27 5374



Aerospace

Key Markets

Aftermarket services
Commercial transports
Engines
General & business aviation
Helicopters
Launch vehicles
Military aircraft
Missiles
Power generation
Regional transports
Unmanned aerial vehicles

Key Products

Control systems & actuation products
Engine systems & components
Fluid conveyance systems & components
Fluid metering, delivery & atomization devices
Fuel systems & components
Fuel tank inerting systems
Hydraulic systems & components
Thermal management
Wheels & brakes



Climate Control

Key Markets

Agriculture
Air conditioning
Construction Machinery
Food & beverage
Industrial machinery
Life sciences
Oil & gas
Precision cooling
Process
Refrigeration
Transportation

Key Products

Accumulators
Advanced actuators
CO₂ controls
Electronic controllers
Filter driers
Hand shut-off valves
Heat exchangers
Hose & fittings
Pressure regulating valves
Refrigerant distributors
Safety relief valves
Smart pumps
Solenoid valves
Thermostatic expansion valves



Electromechanical

Key Markets

Aerospace
Factory automation
Life science & medical
Machine tools
Packaging machinery
Paper machinery
Plastics machinery & converting
Primary metals
Semiconductor & electronics
Textile
Wire & cable

Key Products

AC/DC drives & systems
Electric actuators, gantry robots & slides
Electrohydraulic actuation systems
Electromechanical actuation systems
Human machine interface
Linear motors
Stepper motors, servo motors, drives & controls
Structural extrusions



Filtration

Key Markets

Aerospace
Food & beverage
Industrial plant & equipment
Life sciences
Marine
Mobile equipment
Oil & gas
Power generation & renewable energy
Process
Transportation
Water Purification

Key Products

Analytical gas generators
Compressed air filters & dryers
Engine air, coolant, fuel & oil filtration systems
Fluid condition monitoring systems
Hydraulic & lubrication filters
Hydrogen, nitrogen & zero air generators
Instrumentation filters
Membrane & fiber filters
Microfiltration
Sterile air filtration
Water desalination & purification filters & systems



Fluid & Gas Handling

Key Markets

Aerial lift
Agriculture
Bulk chemical handling
Construction machinery
Food & beverage
Fuel & gas delivery
Industrial machinery
Life sciences
Marine
Mining
Mobile
Oil & gas
Renewable energy
Transportation

Key Products

Check valves
Connectors for low pressure fluid conveyance
Deep sea umbilicals
Diagnostic equipment
Hose couplings
Industrial hose
Mooring systems & power cables
PTFE hose & tubing
Quick couplings
Rubber & thermoplastic hose
Tube fittings & adapters
Tubing & plastic fittings



Hydraulics

Key Markets

Aerial lift
Agriculture
Alternative energy
Construction machinery
Forestry
Industrial machinery
Machine tools
Marine
Material handling
Mining
Oil & gas
Power generation
Refuse vehicles
Renewable energy
Truck hydraulics
Turf equipment

Key Products

Accumulators
Cartridge valves
Electrohydraulic actuators
Human machine interfaces
Hybrid drives
Hydraulic cylinders
Hydraulic motors & pumps
Hydraulic systems
Hydraulic valves & controls
Hydrostatic steering
Integrated hydraulic circuits
Power take-offs
Power units
Rotary actuators
Sensors



Pneumatics

Key Markets

Aerospace
Conveyor & material handling
Factory automation
Life science & medical
Machine tools
Packaging machinery
Transportation & automotive

Key Products

Air preparation
Brass fittings & valves
Manifolds
Pneumatic accessories
Pneumatic actuators & grippers
Pneumatic valves & controls
Quick disconnects
Rotary actuators
Rubber & thermoplastic hose & couplings
Structural extrusions
Thermoplastic tubing & fittings
Vacuum generators, cups & sensors



Process Control

Key Markets

Alternative fuels
Biopharmaceuticals
Chemical & refining
Food & beverage
Marine & shipbuilding
Medical & dental
Microelectronics
Nuclear Power
Offshore oil exploration
Oil & gas
Pharmaceuticals
Power generation
Pulp & paper
Steel
Water/wastewater

Key Products

Analytical Instruments
Analytical sample conditioning products & systems
Chemical injection fittings & valves
Fluoropolymer chemical delivery fittings, valves & pumps
High purity gas delivery fittings, valves, regulators & digital flow controllers
Industrial mass flow meters/controllers
Permanent no-weld tube fittings
Precision industrial regulators & flow controllers
Process control double block & bleeds
Process control fittings, valves, regulators & manifold valves



Sealing & Shielding

Key Markets

Aerospace
Chemical processing
Consumer
Fluid power
General Industrial
Information technology
Life sciences
Microelectronics
Military
Oil & gas
Power generation
Renewable energy
Telecommunications
Transportation

Key Products

Dynamic seals
Elastomeric o-rings
Electro-medical instrument design & assembly
EMI shielding
Extruded & precision-cut, fabricated elastomeric seals
High temperature metal seals
Homogeneous & inserted elastomeric shapes
Medical device fabrication & assembly
Metal & plastic retained composite seals
Shielded optical windows
Silicone tubing & extrusions
Thermal management
Vibration dampening

Parker Worldwide

Europe, Middle East, Africa

AE – United Arab Emirates, Dubai
Tel: +971 4 8127100
parker.me@parker.com

AT – Austria, Wiener Neustadt
Tel: +43 (0)2622 23501-0
parker.austria@parker.com

AT – Eastern Europe, Wiener Neustadt
Tel: +43 (0)2622 23501 900
parker.easteurope@parker.com

AZ – Azerbaijan, Baku
Tel: +994 50 2233 458
parker.azerbaijan@parker.com

BE/LU – Belgium, Nivelles
Tel: +32 (0)67 280 900
parker.belgium@parker.com

BG – Bulgaria, Sofia
Tel: +359 2 980 1344
parker.bulgaria@parker.com

BY – Belarus, Minsk
Tel: +375 17 209 9399
parker.belarus@parker.com

CH – Switzerland, Etoy
Tel: +41 (0)21 821 87 00
parker.switzerland@parker.com

CZ – Czech Republic, Klecany
Tel: +420 284 083 111
parker.czechrepublic@parker.com

DE – Germany, Kaarst
Tel: +49 (0)2131 4016 0
parker.germany@parker.com

DK – Denmark, Ballerup
Tel: +45 43 56 04 00
parker.denmark@parker.com

ES – Spain, Madrid
Tel: +34 902 330 001
parker.spain@parker.com

FI – Finland, Vantaa
Tel: +358 (0)20 753 2500
parker.finland@parker.com

FR – France, Contamine s/Arve
Tel: +33 (0)4 50 25 80 25
parker.france@parker.com

GR – Greece, Athens
Tel: +30 210 933 6450
parker.greece@parker.com

HU – Hungary, Budaörs
Tel: +36 23 885 470
parker.hungary@parker.com

IE – Ireland, Dublin
Tel: +353 (0)1 466 6370
parker.ireland@parker.com

IT – Italy, Corsico (MI)
Tel: +39 02 45 19 21
parker.italy@parker.com

KZ – Kazakhstan, Almaty
Tel: +7 7273 561 000
parker.easteurope@parker.com

NL – The Netherlands, Oldenzaal
Tel: +31 (0)541 585 000
parker.nl@parker.com

NO – Norway, Asker
Tel: +47 66 75 34 00
parker.norway@parker.com

PL – Poland, Warsaw
Tel: +48 (0)22 573 24 00
parker.poland@parker.com

PT – Portugal, Leca da Palmeira
Tel: +351 22 999 7360
parker.portugal@parker.com

RO – Romania, Bucharest
Tel: +40 21 252 1382
parker.romania@parker.com

RU – Russia, Moscow
Tel: +7 495 645-2156
parker.russia@parker.com

SE – Sweden, Spånga
Tel: +46 (0)8 59 79 50 00
parker.sweden@parker.com

SK – Slovakia, Banská Bystrica
Tel: +421 484 162 252
parker.slovakia@parker.com

SL – Slovenia, Novo Mesto
Tel: +386 7 337 6650
parker.slovenia@parker.com

TR – Turkey, Istanbul
Tel: +90 216 4997081
parker.turkey@parker.com

UA – Ukraine, Kiev
Tel +380 44 494 2731
parker.ukraine@parker.com

UK – United Kingdom, Warwick
Tel: +44 (0)1926 317 878
parker.uk@parker.com

ZA – South Africa, Kempton Park
Tel: +27 (0)11 961 0700
parker.southafrica@parker.com

North America

CA – Canada, Milton, Ontario
Tel: +1 905 693 3000

US – USA, Cleveland
Tel: +1 216 896 3000

Asia Pacific

AU – Australia, Castle Hill
Tel: +61 (0)2-9634 7777

CN – China, Shanghai
Tel: +86 21 2899 5000

HK – Hong Kong
Tel: +852 2428 8008

IN – India, Mumbai
Tel: +91 22 6513 7081-85

JP – Japan, Tokyo
Tel: +81 (0)3 6408 3901

KR – South Korea, Seoul
Tel: +82 2 559 0400

MY – Malaysia, Shah Alam
Tel: +60 3 7849 0800

NZ – New Zealand, Mt Wellington
Tel: +64 9 574 1744

SG – Singapore
Tel: +65 6887 6300

TH – Thailand, Bangkok
Tel: +662 186 7000-99

TW – Taiwan, Taipei
Tel: +886 2 2298 8987

South America

AR – Argentina, Buenos Aires
Tel: +54 3327 44 4129

BR – Brazil, Sao Jose dos Campos
Tel: +55 800 727 5374

CL – Chile, Santiago
Tel: +56 2 623 1216

MX – Mexico, Toluca
Tel: +52 72 2275 4200

We reserve the right to make technical changes. The data correspond to the technical state at the time of printing.
© 2013 Parker Hannifin Corporation.
All rights reserved.

192-300202N1

October 2013



EMEA Product Information Centre

Free phone: 00 800 27 27 5374

(from AT, BE, CH, CZ, DE, DK, EE, ES, FI, FR, IE, IL, IS, IT, LU, MT, NL, NO, PL, PT, RU, SE, SK, UK, ZA)

US Product Information Centre

Toll-free number: 1-800-27 27 537

www.parker.com

