



aerospace
climate control
electromechanical
filtration
fluid & gas handling
hydraulics
pneumatics
process control
sealing & shielding



ViX Series

Micro Stepper Drive

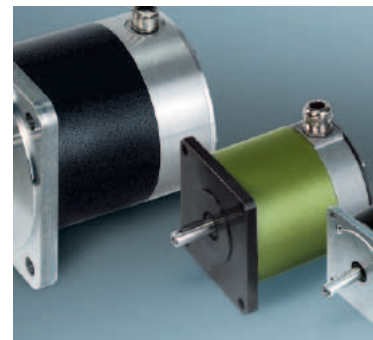

ENGINEERING YOUR SUCCESS.



WARNING – USER RESPONSIBILITY

FAILURE OR IMPROPER SELECTION OR IMPROPER USE OF THE PRODUCTS DESCRIBED HEREIN OR RELATED ITEMS CAN CAUSE DEATH, PERSONAL INJURY AND PROPERTY DAMAGE.

- This document and other information from Parker-Hannifin Corporation, its subsidiaries and authorized distributors provide product or system options for further investigation by users having technical expertise.
- The user, through its own analysis and testing, is solely responsible for making the final selection of the system and components and assuring that all performance, endurance, maintenance, safety and warning requirements of the application are met. The user must analyze all aspects of the application, follow applicable industry standards, and follow the information concerning the product in the current product catalog and in any other materials provided from Parker or its subsidiaries or authorized distributors.
- To the extent that Parker or its subsidiaries or authorized distributors provide component or system options based upon data or specifications provided by the user, the user is responsible for determining that such data and specifications are suitable and sufficient for all applications and reasonably foreseeable uses of the components or systems.

Overview	5
Technical Characteristics.....	7
Technical Data.....	7
Inputs, Outputs, Interfaces	7
Environmental Characteristics.....	8
Standards and Conformance	8
Performance Data.....	8
Dimensions	9
Accessories and Options	9
Power module: VXLPSU240 and VXLPSU960	9
Motor brake controller: VXLCHOP2000	9
Order Code.....	10
ViX Stepper Drive	10
Accessories	10

Parker Hannifin

- the global leader in motion and control technologies

A world class player on a local stage

Global Product Design

Parker Hannifin has more than 40 years experience in the design and manufacturing of drives, controls, motors and mechanical products. With dedicated global product development teams, Parker draws on industry-leading technological leadership and experience from engineering teams in Europe, North America and Asia.

Local Application Expertise

Parker has local engineering resources committed to adapting and applying our current products and technologies to best fit our customers' needs.

Manufacturing to Meet Our Customers' Needs

Parker is committed to meeting the increasing service demands that our customers require to succeed in the global industrial market. Parker's manufacturing teams seek continuous improvement through the implementation of lean manufacturing methods throughout the process. We measure ourselves on meeting our customers' expectations of quality and delivery, not just our own. In order to meet these expectations, Parker operates and continues to invest in our manufacturing facilities in Europe, North America and Asia.

Worldwide Manufacturing Locations

Europe

Littlehampton, United Kingdom
Dijon, France
Offenburg, Germany
Milan, Italy

Asia

Shanghai, China
Chennai, India

North America

Rohnert Park, California
Irwin, Pennsylvania
Wadsworth, Ohio
Charlotte, North Carolina
New Ulm, Minnesota



Offenburg, Germany

Local Manufacturing and Support in Europe

Parker provides sales assistance and local technical support through a network of dedicated sales teams and authorized technical distributors throughout Europe.

For contact information, please refer to the Sales Offices on the back cover of this document or visit www.parker.com



Milan, Italy



Littlehampton, UK

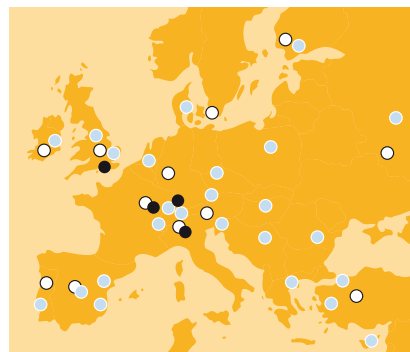

- Manufacturing
- Parker Sales Offices
- Distributors



Dijon, France

Micro Stepper Drive - ViX

Overview

Description

The award-winning ViX intelligent digital servo drive from Parker Hannifin has now been joined by a high-performance microstep version. Like its servo equivalent, the ViX microstep drive uses field-oriented digital control technology to give enhanced dynamic performance with improved efficiency. Housed within an extremely compact case, ViX is suitable either for direct panel mounting or for attachment to a standard DIN rail using an optional adaptor. The ViX microstep drive is produced in two versions having current ratings of 2.8 A and 5.6 A RMS at motor bus voltages up to 80 VDC. User resolution is freely programmable between 400 and 51 200 steps/rev. Regardless of the programmed resolution, the motor always operates at maximum resolution for optimum smoothness over the entire speed range. The power stage features full PWM control for accurate microstepping performance.



Features

- Fully digital design
- Field-oriented control for improved low-speed performance
- Panel or DIN rail mounting
- 2.8 A & 5.6 A (rms)
- Up to 80 V DC bus
- Built-in controller using Parker's proven EASI code
- Powerful front-end software
- Fully-programmable resolution, up to 51 200 increments/rev
- Optional CANopen / RS485 interface
- Automatic standby current reduction
- Compact package
- Compatible with Parker high performance stepper motors

Technical Characteristics - Overview

Device	Continuous current [A _{rms}]	Peak current [A] (<2 s)	Interface	Supply voltage [VDC]
ViX250-IM	2.8	4	Step+ Direction	24 & 24...80
ViX500-IM	5.6	8		24 & 48...80
ViX250-CM	2.8	4	CANopen	24 & 24...80
ViX500-CM	5.6	8		24 & 48...80

Product Description

ViX intelligent microstep drives incorporate a powerful motion controller using Parker's well-proven EASI command language. As well as carrying out all standard motion-related functions, the controller performs more advanced operations such as external encoder following and registration moves. All necessary configuration is performed by software. In addition to an RS232C interface which is included in the standard drive, an optional factory-installed fieldbus expansion module allows for both CANopen and RS485 communication.

A comprehensive front-end software package is available which permits rapid configuration of the drive. When used with Parker stepper motors, only the motor type number is required for configuration of all relevant motor parameters. Parker's power supplies offer a convenient way of powering ViX microstep drives.

ViX forms part of a new, fully-integrated system of motion control components. The ViX microstep drive forms part of a new, fully-integrated system of motion control components which includes digital servo and stepper drives, power supplies, operator panels and I/O expansion units. These components complement Parker's range of mechanical positioning systems which includes precision tables, electric cylinders and linear actuators.

Digital technology

The operating core of the ViX microstep drive is based on a powerful microprocessor. Armed with information about the motor and drive parameters, the processor is able to set the operating conditions in the current loop with a high degree of precision. In this way the bandwidth of the torque amplifier can be optimized for the specific configuration, allowing a wide range of motors to be accommodated without compromising on performance. In this way the bandwidth of the output amplifier can be optimized for the specific configuration, allowing a wide range of motors to be accommodated without compromising on performance. In addition, set-up is exceptionally straightforward with the relevant data for Parker high-performance stepper motors being held in a database within the EASI-V software package.

Flexible communication options

ViX is supplied as standard with an integral RS232 communication interface. To keep the wiring as simple as possible, dual RJ45 connectors on the underside of the drive provide a built in daisy-chaining facility. The last drive in the chain automatically detects that no more units are connected and creates a loop return back to the host controller. Optional built-in modules provide both RS485 and CANopen communication to allow for integration within fieldbus systems.

Freely-programmable user resolution

The ViX microstep drive is exceptionally easy to integrate into any mechanical arrangement since the user resolution may be set anywhere between 400 and 51 200 steps/rev. This means you can always set distances within your program using convenient units, even if there is an odd transmission ratio or leadscrew pitch. Moreover, the drive power stage always operates at maximum resolution.



Technical Characteristics

Technical Data

ViX stepper drive

Model ViX		ViX250	ViX500
	Unit		
Supply voltage and current			
Supply voltage	[V]	24...80 VDC +5 % -15 %	48...80 VDC +5 % - 15 %
Input current	[A]	2.8 (typ. 2...2.5)	5.6 (typ. 4...5)
Capacitance power module	[µF]	3300	6600
Nominal current (rms)	[A]	2.5	5.6
Peak current	[A]	4	8
Logic voltage	[V]	24 VDC (21...27 VDC), 250 mA (without encoder, brake, outputs), additional 50 mA for fieldbus extension module	
Motor inductance	[mH]	0.5...20 mH recommended	
Motor current	[A]	Software-programmable up to 50 % of the nominal current	
Standby current		50 % to 100 % of programmed current, software-selectable (including delay)	
Internal motor resolution		51 200 steps/rev (fixed)	
User resolution		is freely programmable between 400 and 51 200 steps/rev.	

Inputs, Outputs, Interfaces

Protection	<ul style="list-style-type: none"> • Short circuit (phase to phase, phase to ground) • Motor HV over & under-voltage trip • Drive/motor overtemperature • Reverse polarity on 24 V input • Encoder fault
Encoder (optional)	<p>Standard quadrature encoder: 5 V differential, 200 kHz max. channel frequency, resolution between 500 and 5000 lines (i.e. up to 20 000 counts/rev). Encoder supply: 5 V output, 350 mA maximum loading</p>
Inputs / outputs	<ul style="list-style-type: none"> • Analog input: ±10 V differential, 12 bit resolution, velocity or torque demand and feed rate override • Position commanding/following encoder input: Step/direction, step+/step- or quadrature encoder input mirrors the feedback encoder • Digital inputs: 5 (4 are configurable as Home, Limits & Registration. Operating range 5...24 V, Software-configurable 4K7 pull-up/active low or 4K7 pull-down/active high) • Digital outputs: 3, Software-configurable active-low/sinking (5 V-24 V) or active-high/sourcing (24 V only). 50 mA max. per output • Encoder output: Step/direction, step+/step- or quadrature, mirrors the feedback encoder • Fault output: NPN open-collector output, normally low, active high
Communication interface	<ul style="list-style-type: none"> • RS232 (standard) • RS485 • CANopen
High-speed interface	<p>Dual RJ45 connectors for CANopen, RS485 etc. (also provide daisy-chain ports for multi-axis RS232 connections)</p>
Indicators	<p>LEDs for HV/feedback fault, drive fault & comms status</p>

Environmental Characteristics

Temperature range

0...50 °C local environment (airflow>0.5 m/s required above 40 °C)

Humidity

95 % non-condensing

Standards and Conformance

CE - conformance and UL - listing

- CE marked
- UL recognized - E194158

Performance Data

ViX stepper motor drive with SY stepper motor

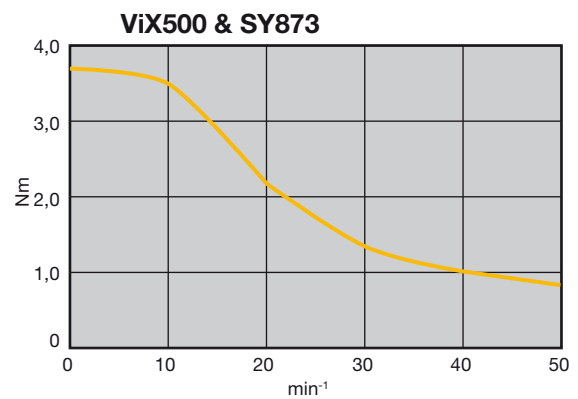
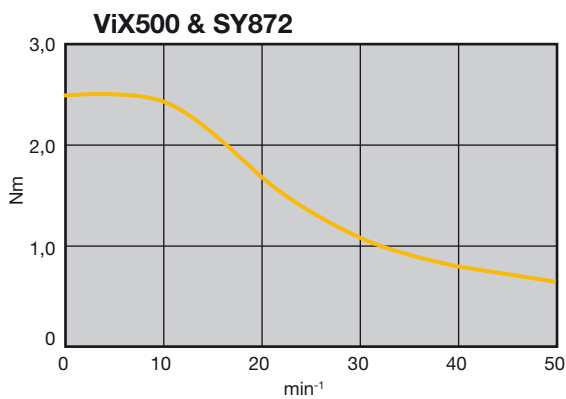
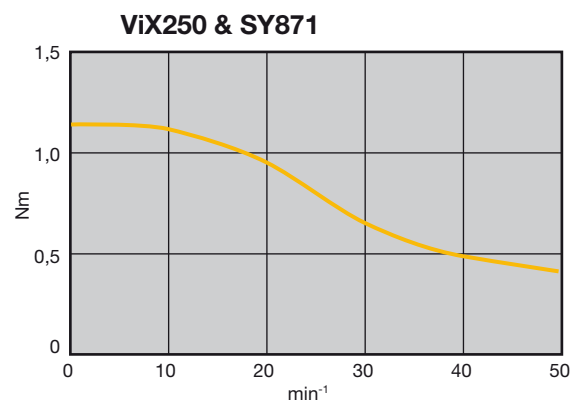
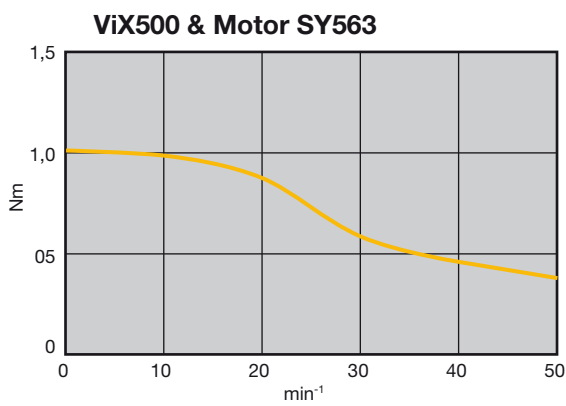
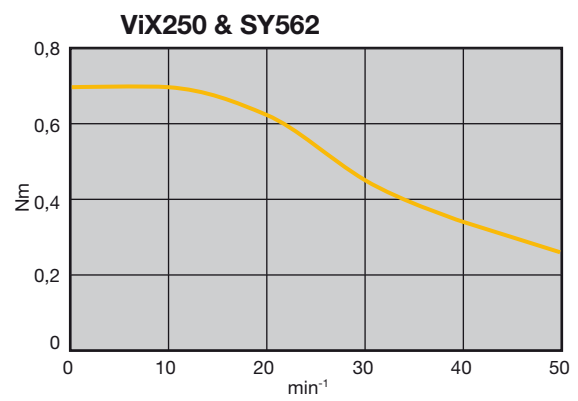
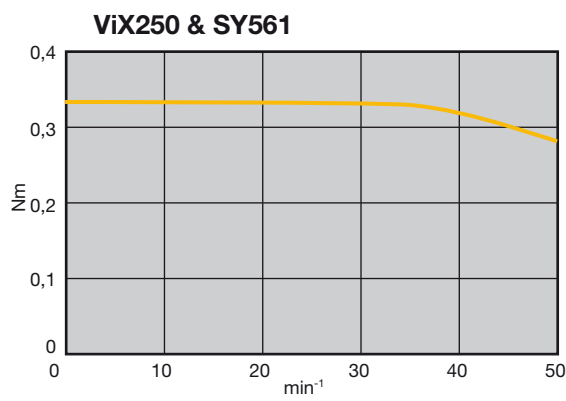

Dimensions

ViX stepper drive

Dimensions [mm]

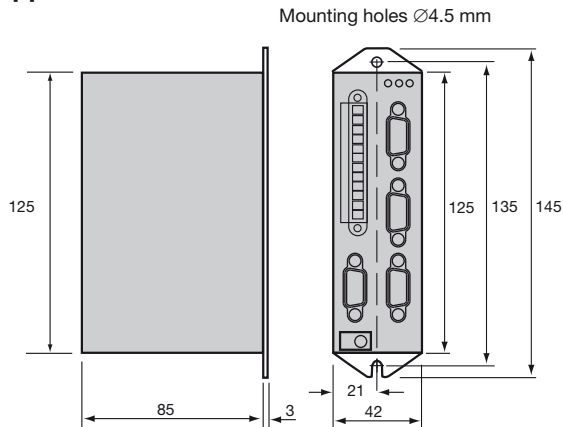

Mounting

vertical mounting, min. clearance 50 mm above & below drive, 10 mm each side panel
mounting standard, DIN rail adaptor available

Accessories and Options

Parker offers a range of accessories for ViX drives including mating connector sets, motor cables and a DIN rail mounting kit. The range will be extended to include operator panels and I/O expansion modules.

Power module: VXLPSU240 and VXLPSU960

The Parker power supply offers a convenient way of powering a ViX servo drive. The continuous rated output is 240 W at 230 VAC input and supplies the 80 V main DC rail and operates directly from all AC supplies between 90 V and 264 V. No external EMC filters are required unless the motor leads are exceptionally long (e.g. greater than 30 m).

Technical characteristics

Power module:	VXLPSU240	VXLPSU960
AC input voltage, nominal (absolute limits)	115...230 VAC, 1phase (90...264 VAC)	400...500 VAC, 3phase
DC voltage	80 VDC, 3 A	80 VDC, 12 A
Rated output	240 W	960 W
Power factor	>0.895	>0.92
Dimensions (HxWxD)	140x63.5x118 mm	127x80x139 mm
Weight	0.720 kg	1.2 kg

Motor brake controller: VXLCHOP2000

The function of the VXLCHOP2000 is to dissipate the energy delivered by the motor in an external resistor thus damping the resulting overvoltage on the DC Bus. Up to 4 VXLCHOP2000 units can be connected in parallel to increase the braking power.

Technical characteristics

Motor brake controller:	VXLCHOP2000
DC voltage	80 VDC (24...110 VDC)
Rated output	2 kW
External braking resistor	≥2 kW, 5 Ω (provided by the customer)
Dimensions (HxWxD)	115x39x128 mm
Weight	0.2 kg

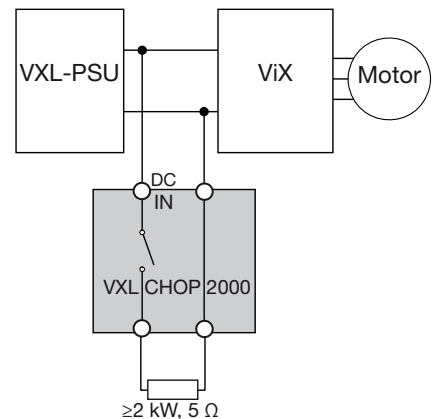

Order Code

ViX Stepper Drive

	1	2	3	4
Ordering example	ViX	250	I	M

1 Device type	ViX	ViX stepper drive
2 Power	250	250 VA
	500	500 VA
3 Controlling	I	Internal controller
	C	CAN & RS485-interface
4	M	Microstep motor drive

Accessories

Power module

	1	2
Ordering example	VXLPSU	240

1 Device type	VXLPSU	Power module
2 Rated power	240	240 W
	960	960 W

Motor brake controller

	1	2
Ordering example	VXLCHOP	2000

1 Device type	VXLCHOP	Motor brake controller
2 Rated power	2000	2 kW

Parker's Motion & Control Technologies

At Parker, we're guided by a relentless drive to help our customers become more productive and achieve higher levels of profitability by engineering the best systems for their requirements. It means looking at customer applications from many angles to find new ways to create value. Whatever the motion and control technology need, Parker has the experience, breadth of product and global reach to consistently deliver. No company knows more about motion and control technology than Parker. For further info call 00800 27 27 5374.



AEROSPACE

Key Markets

- Aircraft engines
- Business & general aviation
- Commercial transports
- Land-based weapons systems
- Military aircraft
- Missiles & launch vehicles
- Regional transports
- Unmanned aerial vehicles

Key Products

- Flight control systems & components
- Fluid conveyance systems
- Fluid metering delivery & atomization devices
- Fuel systems & components
- Hydraulic systems & components
- Inert nitrogen generating systems
- Pneumatic systems & components
- Wheels & brakes



CLIMATE CONTROL

Key Markets

- Agriculture
- Air conditioning
- Food, beverage & dairy
- Life sciences & medical
- Precision cooling
- Processing
- Transportation

Key Products

- CO² controls
- Electronic controllers
- Filter driers
- Hand shut-off valves
- Hose & fittings
- Pressure regulating valves
- Refrigerant distributors
- Safety relief valves
- Solenoid valves
- Thermostatic expansion valves



ELECTROMECHANICAL

Key Markets

- Aerospace
- Factory automation
- Food & beverage
- Life science & medical
- Machine tools
- Packaging machinery
- Paper machinery
- Plastics machinery & converting
- Primary metals
- Semiconductor & electronics
- Textile
- Wire & cable

Key Products

- AC/DC drives & systems
- Electric actuators
- Controllers
- Gantry robots
- Gearheads
- Human machine interfaces
- Industrial PCs
- Inverters
- Linear motors, slides and stages
- Precision stages
- Stepper motors
- Servo motors, drives & controls
- Structural extrusions



FILTRATION

Key Markets

- Food & beverage
- Industrial machinery
- Life sciences
- Marine
- Mobile equipment
- Oil & gas
- Power generation
- Process
- Transportation

Key Products

- Analytical gas generators
- Compressed air & gas filters
- Condition monitoring
- Engine air, fuel & oil filtration & systems
- Hydraulic, lubrication & coolant filters
- Process, chemical, water & microfiltration filters
- Nitrogen, hydrogen & zero air generators



FLUID & GAS HANDLING

Key Markets

- Aerospace
- Agriculture
- Bulk chemical handling
- Construction machinery
- Food & beverage
- Fuel & gas delivery
- Industrial machinery
- Mobile
- Oil & gas
- Transportation
- Welding

Key Products

- Brass fittings & valves
- Diagnostic equipment
- Fluid conveyance systems
- Industrial hose
- PTFE & PFA hose, tubing & plastic fittings
- Rubber & thermoplastic hose & couplings
- Tube fittings & adapters
- Quick disconnects



HYDRAULICS

Key Markets

- Aerospace
- Aerial lift
- Agriculture
- Construction machinery
- Forestry
- Industrial machinery
- Mining
- Oil & gas
- Power generation & energy
- Truck hydraulics

Key Products

- Diagnostic equipment
- Hydraulic cylinders & accumulators
- Hydraulic motors & pumps
- Hydraulic systems
- Hydraulic valves & controls
- Power take-offs
- Rubber & thermoplastic hose & couplings
- Tube fittings & adapters
- Quick disconnects



PNEUMATICS

Key Markets

- Aerospace
- Conveyor & material handling
- Factory automation
- Food & beverage
- Life science & medical
- Machine tools
- Packaging machinery
- Transportation & automotive

Key Products

- Air preparation
- Compact cylinders
- Field bus valve systems
- Grippers
- Guided cylinders
- Manifolds
- Miniature fluidics
- Pneumatic accessories
- Pneumatic actuators & grippers
- Pneumatic valves and controls
- Rodless cylinders
- Rotary actuators
- Tie rod cylinders
- Vacuum generators, cups & sensors



PROCESS CONTROL

Key Markets

- Chemical & refining
- Food, beverage & dairy
- Medical & dental
- Microelectronics
- Oil & gas
- Power generation

Key Products

- Analytical sample conditioning products & systems
- Fluoropolymer chemical delivery fittings, valves & pumps
- High purity gas delivery fittings, valves & regulators
- Instrumentation fittings, valves & regulators
- Medium pressure fittings & valves
- Process control manifolds



SEALING & SHIELDING

Key Markets

- Aerospace
- Chemical processing
- Consumer
- Energy, oil & gas
- Fluid power
- General industrial
- Information technology
- Life sciences
- Military
- Semiconductor
- Telecommunications
- Transportation

Key Products

- Dynamic seals
- Elastomeric o-rings
- EMI shielding
- Extruded & precision-cut, fabricated elastomeric seals
- Homogeneous & inserted elastomeric shapes
- High temperature metal seals
- Metal & plastic retained composite seals
- Thermal management

Parker Worldwide

Europe, Middle East, Africa

AE – United Arab Emirates,
Dubai

Tel: +971 4 8127100
parker.me@parker.com

AT – Austria, Wiener Neustadt

Tel: +43 (0)2622 23501-0
parker.austria@parker.com

AT – Eastern Europe, Wiener
Neustadt

Tel: +43 (0)2622 23501 900
parker.easteurope@parker.com

AZ – Azerbaijan, Baku

Tel: +994 50 2233 458
parker.azerbaijan@parker.com

BE/LU – Belgium, Nivelles

Tel: +32 (0)67 280 900
parker.belgium@parker.com

BY – Belarus, Minsk

Tel: +375 17 209 9399
parker.belarus@parker.com

CH – Switzerland, Etoy

Tel: +41 (0)21 821 87 00
parker.switzerland@parker.com

CZ – Czech Republic, Klecany

Tel: +420 284 083 111
parker.czechrepublic@parker.com

DE – Germany, Kaarst

Tel: +49 (0)2131 4016 0
parker.germany@parker.com

DK – Denmark, Ballerup

Tel: +45 43 56 04 00
parker.denmark@parker.com

ES – Spain, Madrid

Tel: +34 902 330 001
parker.spain@parker.com

FI – Finland, Vantaa

Tel: +358 (0)20 753 2500
parker.finland@parker.com

FR – France, Contamine s/Arve

Tel: +33 (0)4 50 25 80 25
parker.france@parker.com

GR – Greece, Athens

Tel: +30 210 933 6450
parker.greece@parker.com

HU – Hungary, Budapest

Tel: +36 1 220 4155
parker.hungary@parker.com

IE – Ireland, Dublin

Tel: +353 (0)1 466 6370
parker.ireland@parker.com

IT – Italy, Corsico (MI)

Tel: +39 02 45 19 21
parker.italy@parker.com

KZ – Kazakhstan, Almaty

Tel: +7 7272 505 800
parker.easteurope@parker.com

NL – The Netherlands, Oldenzaal

Tel: +31 (0)541 585 000
parker.nl@parker.com

NO – Norway, Asker

Tel: +47 66 75 34 00
parker.norway@parker.com

PL – Poland, Warsaw

Tel: +48 (0)22 573 24 00
parker.poland@parker.com

PT – Portugal, Leca da Palmeira

Tel: +351 22 999 7360
parker.portugal@parker.com

RO – Romania, Bucharest

Tel: +40 21 252 1382
parker.romania@parker.com

RU – Russia, Moscow

Tel: +7 495 645-2156
parker.russia@parker.com

SE – Sweden, Spånga

Tel: +46 (0)8 59 79 50 00
parker.sweden@parker.com

SK – Slovakia, Banská Bystrica

Tel: +421 484 162 252
parker.slovakia@parker.com

SL – Slovenia, Novo Mesto

Tel: +386 7 337 6650
parker.slovenia@parker.com

TR – Turkey, Istanbul

Tel: +90 216 4997081
parker.turkey@parker.com

UA – Ukraine, Kiev

Tel +380 44 494 2731
parker.ukraine@parker.com

UK – United Kingdom, Warwick

Tel: +44 (0)1926 317 878
parker.uk@parker.com

ZA – South Africa, Kempton Park

Tel: +27 (0)11 961 0700
parker.southafrica@parker.com

North America

CA – Canada, Milton, Ontario

Tel: +1 905 693 3000

US – USA, Cleveland

Tel: +1 216 896 3000

Asia Pacific

AU – Australia, Castle Hill

Tel: +61 (0)2-9634 7777

CN – China, Shanghai

Tel: +86 21 2899 5000

HK – Hong Kong

Tel: +852 2428 8008

IN – India, Mumbai

Tel: +91 22 6513 7081-85

JP – Japan, Tokyo

Tel: +81 (0)3 6408 3901

KR – South Korea, Seoul

Tel: +82 2 559 0400

MY – Malaysia, Shah Alam

Tel: +60 3 7849 0800

NZ – New Zealand, Mt Wellington

Tel: +64 9 574 1744

SG – Singapore

Tel: +65 6887 6300

TH – Thailand, Bangkok

Tel: +662 186 7000-99

TW – Taiwan, Taipei

Tel: +886 2 2298 8987

South America

AR – Argentina, Buenos Aires

Tel: +54 3327 44 4129

BR – Brazil, Sao Jose dos Campos

Tel: +55 800 727 5374

CL – Chile, Santiago

Tel: +56 2 623 1216

MX – Mexico, Apodaca

Tel: +52 81 8156 6000

We reserve the right to make technical changes. The data correspond to the technical state at the time of printing.
© 2011 Parker Hannifin Corporation.
All rights reserved.

192-070101N3

October 2011



EMEA Product Information Centre

Free phone: 00 800 27 27 5374

(from AT, BE, CH, CZ, DE, DK, EE, ES, FI, FR, IE, IL, IS, IT, LU, MT, NL, NO, PL, PT, RU, SE, SK, UK, ZA)

US Product Information Centre

Toll-free number: 1-800-27 27 537

www.parker.com

Your local authorized Parker distributor